

# 5841 AND 5842

## BiMOS II 8-BIT SERIAL-INPUT, LATCHED DRIVERS

### UCN5841A & UCN5842A

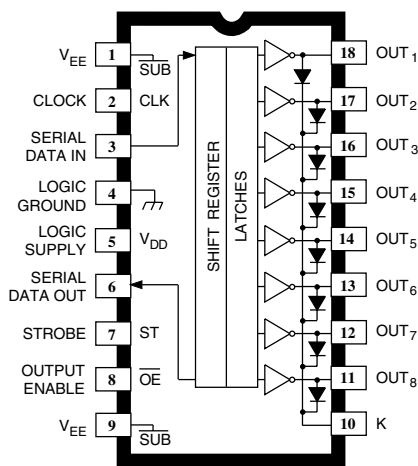

Dwg. PP-026-1

Note that the UCN584xA (dual in-line package) and UCN584xLW (small-outline IC package) are electrically identical and share a common terminal number assignment.

### ABSOLUTE MAXIMUM RATINGS at 25°C Free-Air Temperature

Output Voltage, $V_{CE}$	
(5841) .....	50 V
(5842) .....	80 V
Output Voltage, $V_{CE(sus)}$	
(5841) .....	35 V†
(5842) .....	50 V†
Logic Supply Voltage Range,	
$V_{DD}$ .....	4.5 V to 15 V
$V_{DD}$ with Reference to $V_{EE}$ .....	25 V
Emitter Supply Voltage, $V_{EE}$ .....	-20 V
Input Voltage Range,	
$V_{IN}$ .....	-0.3 V to $V_{DD} + 0.3$ V
Continuous Output Current,	
$I_{OUT}$ .....	500 mA
Package Power Dissipation,	
$P_D$ .....	See Graph
Operating Temperature Range,	
$T_A$ .....	-20°C to +85°C
Storage Temperature Range,	
$T_S$ .....	-55°C to +150°C

†For inductive load applications.

Caution: CMOS devices have input static protection but are susceptible to damage when exposed to extremely high static electrical charges.

The merging of low-power CMOS logic and bipolar output power drivers permit the UCN5841/42A, UCN5841/42LW, and A5841/42SLW integrated circuits to be used in a wide variety of peripheral power driver applications. Each device has an eight-bit CMOS shift register and CMOS control circuitry, eight CMOS data latches, and eight bipolar current-sinking Darlington output drivers. The 500 mA npn Darlington outputs, with integral transient-suppression diodes, are suitable for use with relays, solenoids, and other inductive loads. Except for packaging and the maximum driver output voltage ratings, the UCN5841A, UCN5841LW, A5841SLW, UCN5842A, UCN5842LW, and A5842SLW are identical. All package variations of the 5842 offer premium performance with a minimum output-breakdown voltage rating of 80 V (50 V sustaining). All drivers can be operated with a split supply where the negative supply is up to -20 V.

BiMOS II devices have higher data-input rates than the earlier BiMOS circuits. With a 5 V logic supply, they will typically operate at better than 5 MHz. With a 12 V supply, significantly higher speeds are obtained. The CMOS inputs are compatible with standard CMOS and NMOS logic levels. TTL circuits may require the use of appropriate pull-up resistors. By using the serial data output, drivers can be cascaded for interface applications requiring additional drive lines.

The UCN584xA devices are furnished in a standard 18-pin plastic DIP; the UCN584xLW devices are in an 18-lead surface-mountable wide-body SOIC package; the A584xSLW devices are provided in a 20-lead wide-body SOIC package with improved thermal characteristics.

The A5841SLW and UCN5841LW drivers are also available for operation to a temperature of -40°C. To order, change the suffix from 'SLW' to 'ELW', or change the prefix from 'UCN' to 'UCQ'.

### FEATURES

- To 3.3 MHz Data-Input Rate
- CMOS, NMOS, TTL Compatible Inputs
- Internal Pull-Up/Pull-Down Resistors
- Low-Power CMOS Logic and Latches,
- High-Voltage Current-Sink Outputs
- Output Transient-Protection Diodes
- Single or Split Supply Operation
- DIP or SOIC Packaging
- Automotive Capable

Always order by complete part number, e.g., **A5841SLW**.

# 5841 AND 5842 8-BIT SERIAL-INPUT, LATCHED DRIVERS

## FUNCTIONAL BLOCK DIAGRAM (‘A’ Package Shown)

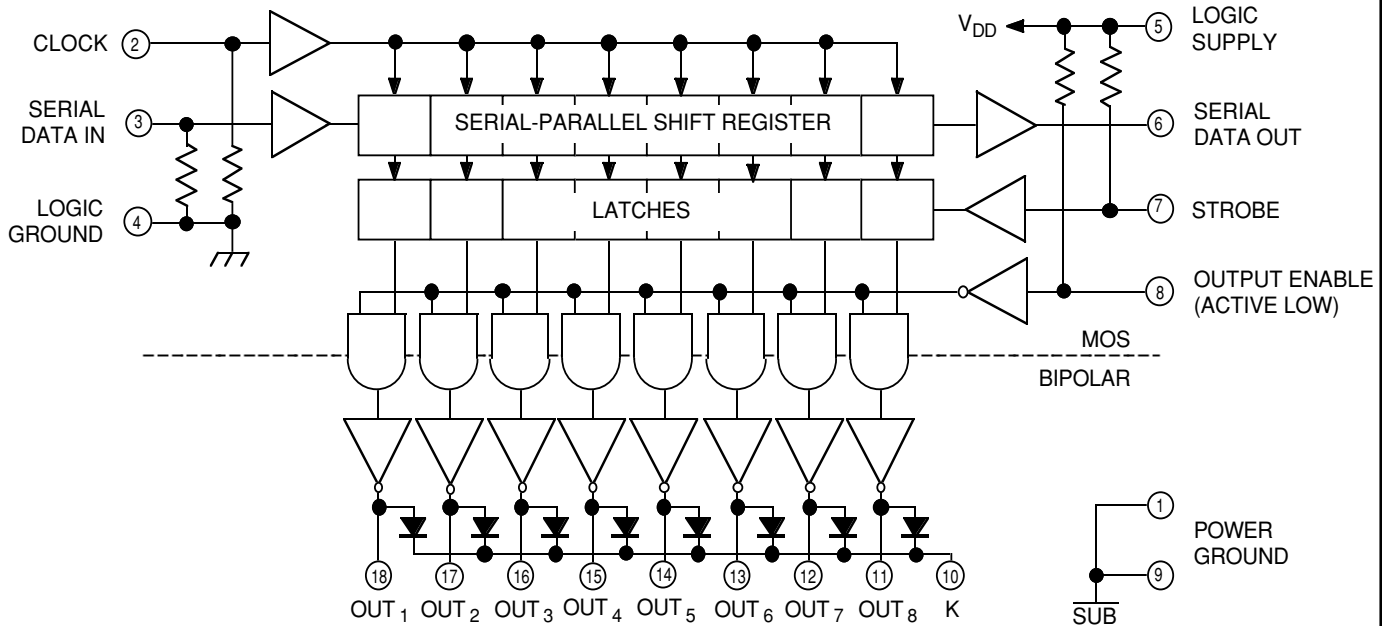

Dwg. FP-013-2

## A5841SLW & A5842SLW

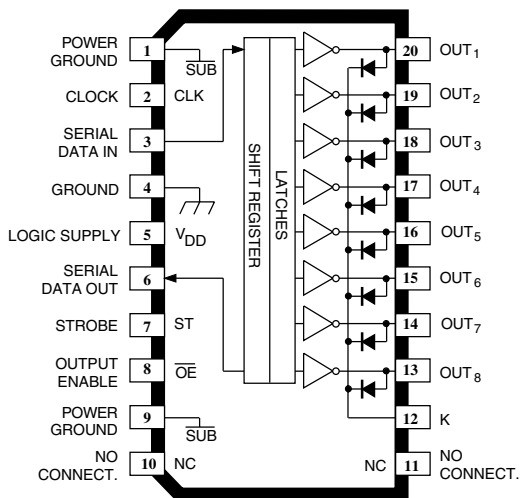

Dwg. PP-029-3

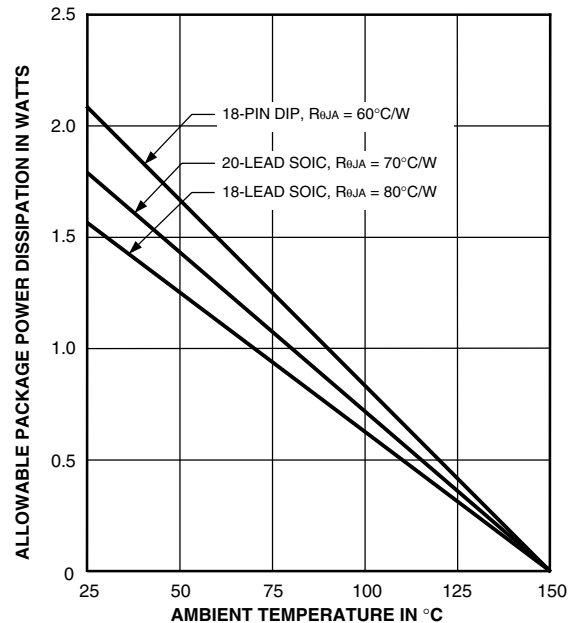

Dwg. GP-022-4



# 5841 AND 5842 8-BIT SERIAL-INPUT, LATCHED DRIVERS

**ELECTRICAL CHARACTERISTICS at  $T_A = +25^\circ\text{C}$ ,  $V_{DD} = 5\text{ V}$ ,  $V_{EE} = 0\text{ V}$   
(unless otherwise specified).**

Characteristic	Symbol	Applicable Devices	Test Conditions	Limits		
				Min.	Max.	Unit
Output Leakage Current	$I_{CEX}$	5841*	$V_{OUT} = 50\text{ V}$	—	50	$\mu\text{A}$
			$V_{OUT} = 50\text{ V}$ , $T_A = +70^\circ\text{C}$	—	100	$\mu\text{A}$
		5842*	$V_{OUT} = 80\text{ V}$	—	50	$\mu\text{A}$
			$V_{OUT} = 80\text{ V}$ , $T_A = +70^\circ\text{C}$	—	100	$\mu\text{A}$
Collector-Emitter Saturation Voltage	$V_{CE(SAT)}$	All	$I_{OUT} = 100\text{ mA}$	—	1.1	V
			$I_{OUT} = 200\text{ mA}$	—	1.3	V
			$I_{OUT} = 350\text{ mA}$ , $V_{DD} = 7.0\text{ V}$	—	1.6	V
Collector-Emitter Sustaining Voltage	$V_{CE(sus)}$	5841*	$I_{OUT} = 350\text{ mA}$ , $L = 2\text{ mH}$	35	—	V
		5842*	$I_{OUT} = 350\text{ mA}$ , $L = 2\text{ mH}$	50	—	V
Input Voltage	$V_{IN(0)}$	All		—	0.8	V
	$V_{IN(1)}$	All	$V_{DD} = 12\text{ V}$	10.5	—	V
			$V_{DD} = 10\text{ V}$	8.5	—	V
			$V_{DD} = 5.0\text{ V}$	3.5	—	V
Input Resistance	$R_{IN}$	All	$V_{DD} = 12\text{ V}$	50	—	$\text{k}\Omega$
			$V_{DD} = 10\text{ V}$	50	—	$\text{k}\Omega$
			$V_{DD} = 5.0\text{ V}$	50	—	$\text{k}\Omega$
Supply Current	$I_{DD(ON)}$	All	All Drivers ON, $V_{DD} = 12\text{ V}$	—	16	mA
			All Drivers ON, $V_{DD} = 10\text{ V}$	—	14	mA
			All Drivers ON, $V_{DD} = 5.0\text{ V}$	—	8.0	mA
	$I_{DD(OFF)}$	All	All Drivers OFF, $V_{DD} = 12\text{ V}$	—	2.9	mA
			All Drivers OFF, $V_{DD} = 10\text{ V}$	—	2.5	mA
			All Drivers OFF, $V_{DD} = 5.0\text{ V}$	—	1.6	mA
Clamp Diode Leakage Current	$I_R$	5841*	$V_R = 50\text{ V}$	—	50	$\mu\text{A}$
		5842*	$V_R = 80\text{ V}$	—	50	$\mu\text{A}$
Clamp Diode Forward Voltage	$V_F$	All	$I_F = 350\text{ mA}$	—	2.0	V

\* Complete part number includes a prefix (A or UCN) and a suffix (A, LW, or SLW) as follows:  
UCN5841A, UCN5841LW, or A5841SLW,  
UCN5842A, UCN5842LW, or A5842SLW.

# 5841 AND 5842 8-BIT SERIAL-INPUT, LATCHED DRIVERS

## TYPICAL INPUT CIRCUITS

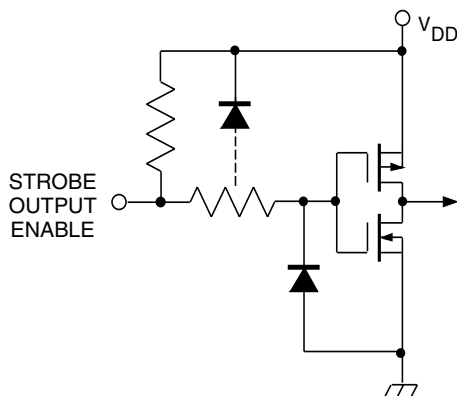

Dwg. EP-010-3

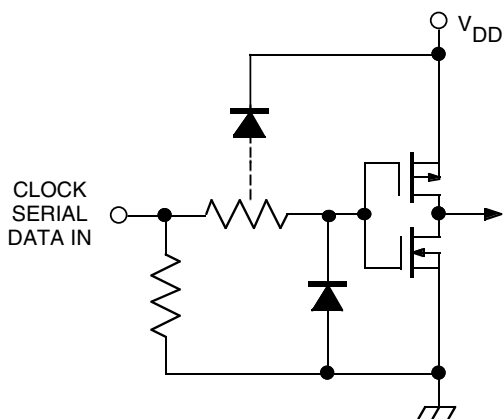

Dwg. EP-010-4A

## TYPICAL OUTPUT DRIVER

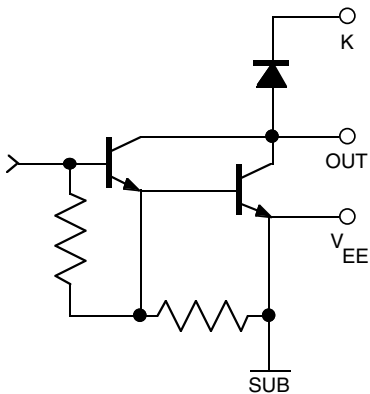

Dwg. EP-021-8

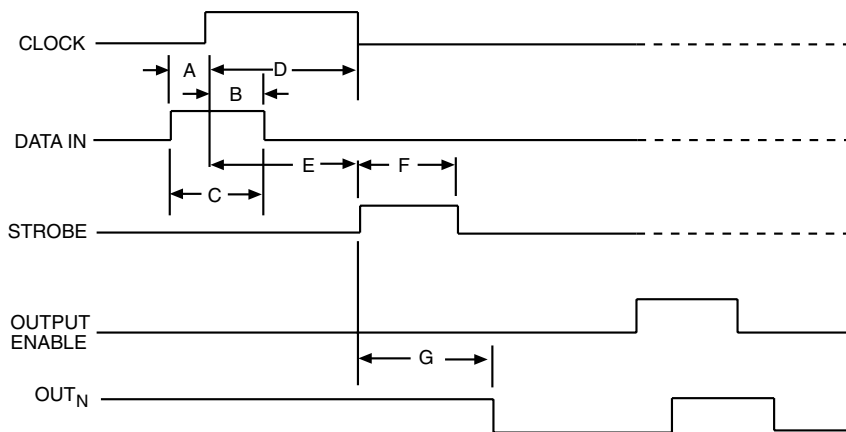

Dwg. No. A-12,627

## TIMING CONDITIONS

( $T_A = +25^\circ\text{C}$ ,  $V_{DD} = 5.0\text{ V}$ , Logic Levels are  $V_{DD}$  and Ground)

- A. Minimum Data Active Time Before Clock Pulse  
(Data Set-Up Time) ..... **75 ns**
- B. Minimum Data Active Time After Clock Pulse  
(Data Hold Time) ..... **75 ns**
- C. Minimum Data Pulse Width ..... **150 ns**
- D. Minimum Clock Pulse Width ..... **150 ns**
- E. Minimum Time Between Clock Activation and Strobe ..... **300 ns**
- F. Minimum Strobe Pulse Width ..... **100 ns**
- G. Typical Time Between Strobe Activation and  
Output Transition ..... **1.0  $\mu\text{s}$**

Serial Data present at the input is transferred to the shift register on the logic "0" to logic "1" transition of the CLOCK input pulse. On succeeding CLOCK pulses, the registers shift data information towards the SERIAL DATA OUTPUT. The SERIAL DATA must appear at the input prior to the rising edge of the CLOCK input waveform.

Information present at any register is transferred to its respective latch when the STROBE is high (serial-to-parallel conversion). The latches will continue to accept new data as long as the STROBE is held high. Applications where the latches are bypassed (STROBE tied high) will require that the ENABLE input be high during serial data entry.

When the ENABLE input is high, all of the output buffers are disabled (OFF) without affecting the information stored in the latches or shift register. With the ENABLE input low, the outputs are controlled by the state of the latches.



# 5841 AND 5842 8-BIT SERIAL-INPUT, LATCHED DRIVERS

## UCN5841A and UCN5842A

Dimensions in Inches  
(controlling dimensions)

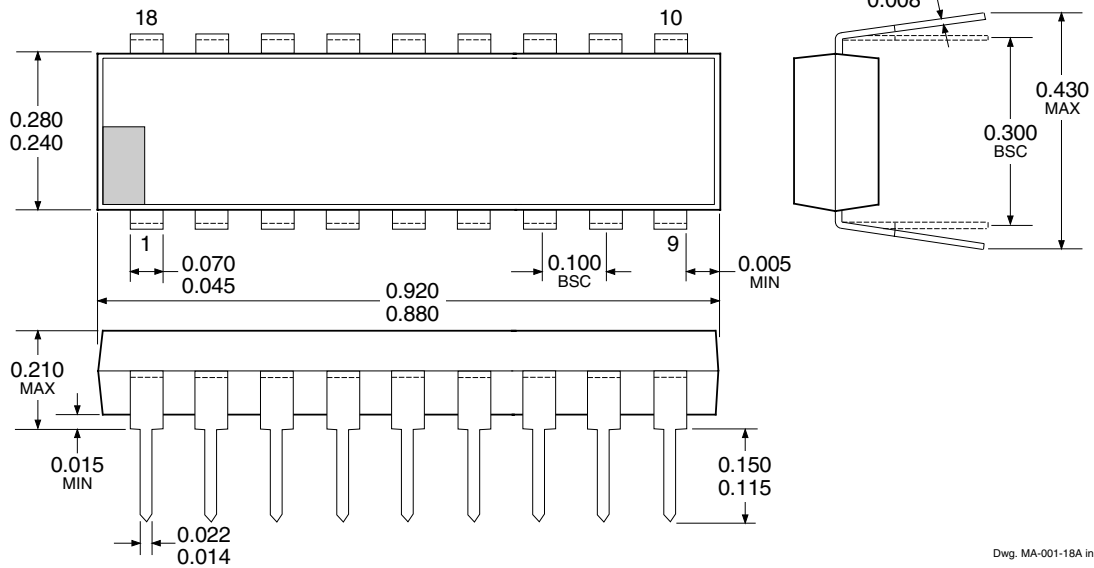

Dimensions in Millimeters  
(for reference only)

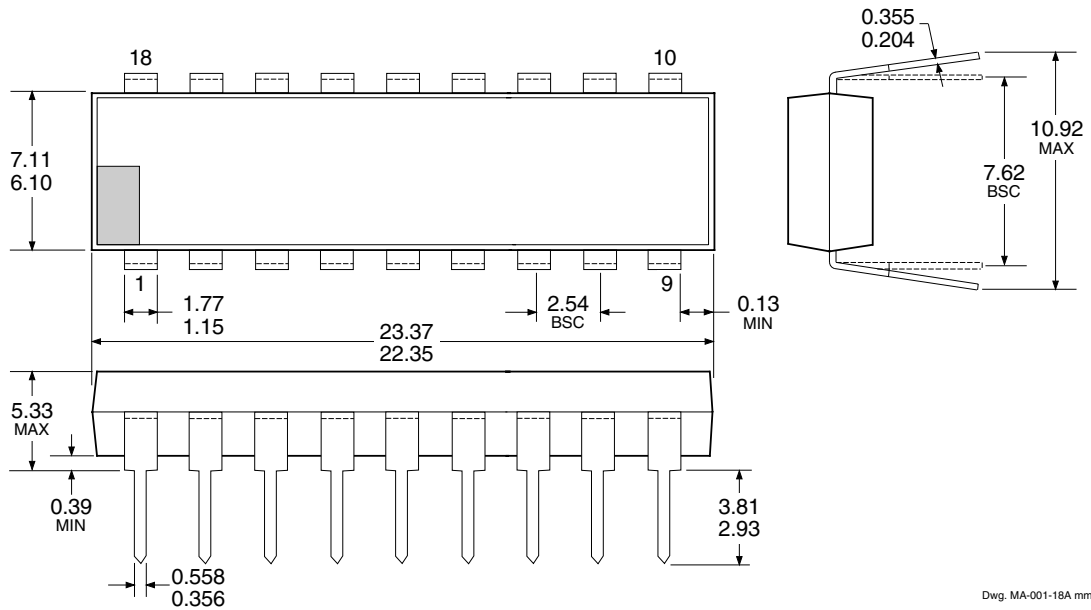

- NOTES: 1. Exact body and lead configuration at vendor's option within limits shown.  
2. Lead spacing tolerance is non-cumulative.  
3. Lead thickness is measured at seating plane or below.

# 5841 AND 5842 8-BIT SERIAL-INPUT, LATCHED DRIVERS

## UCN5841LW and UCN5842LW

Dimensions in Inches  
(for reference only)

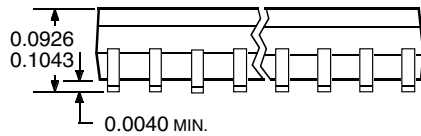
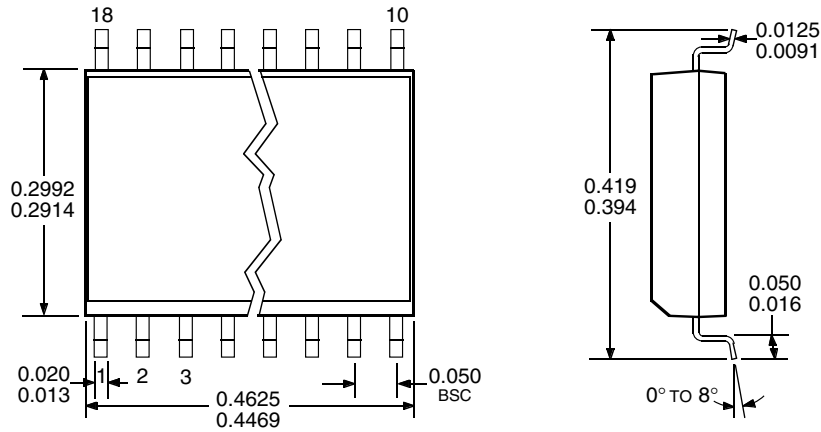

Dwg. MA-008-18A in

Dimensions in Millimeters  
(controlling dimensions)

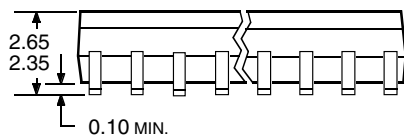
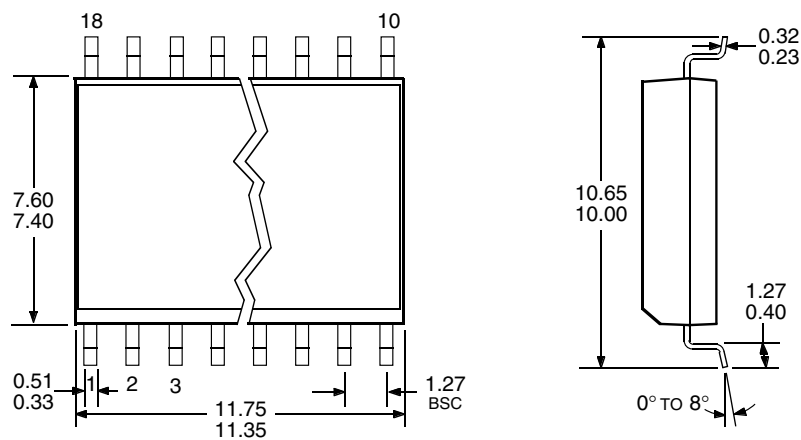

Dwg. MA-008-18A mm

- NOTES: 1. Exact body and lead configuration at vendor's option within limits shown.  
2. Lead spacing tolerance is non-cumulative.

# 5841 AND 5842 8-BIT SERIAL-INPUT, LATCHED DRIVERS

## A5841SLW and A5842SLW

Dimensions in Inches  
(for reference only)

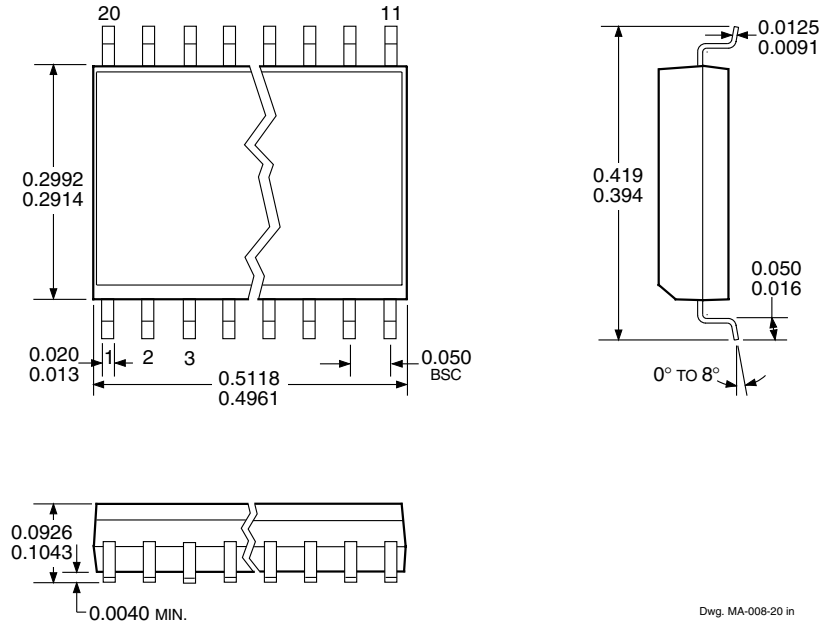

Dimensions in Millimeters  
(controlling dimensions)

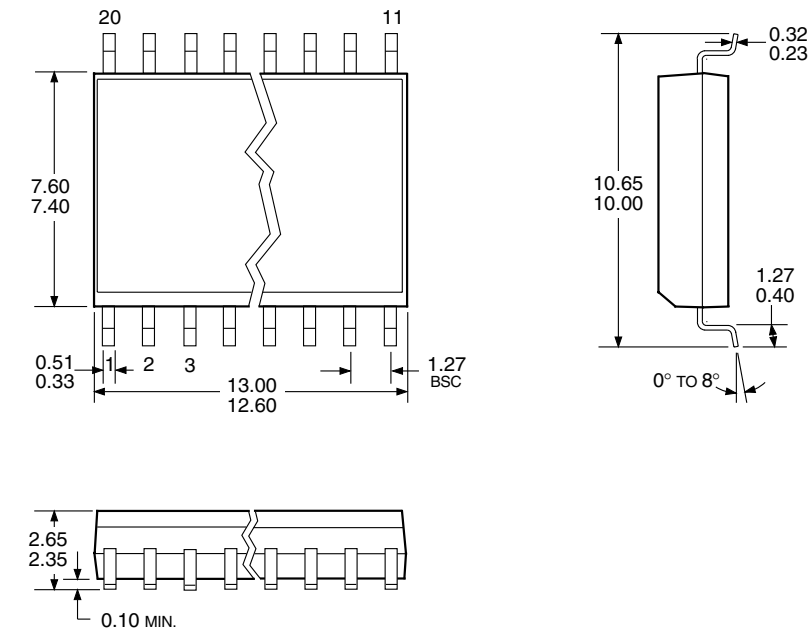

- NOTES: 1. Exact body and lead configuration at vendor's option within limits shown.  
2. Lead spacing tolerance is non-cumulative.



LittleDiode supplies new, hard to find or obsolete electronic components and semiconductors all over the world.

With over two million different components listed you are sure to find the part you need.

Feel free to visit us today at our online store:

[LittleDiode.com](http://LittleDiode.com)

Looking forward to providing you with the best possible service.