

# Am29F080B

8 Megabit (1 M x 8-Bit)

CMOS 5.0 Volt-only, Uniform Sector Flash Memory

## DISTINCTIVE CHARACTERISTICS

- **5.0 V  $\pm$  10%, single power supply operation**
  - Minimizes system level power requirements
- **Manufactured on 0.35  $\mu$ m process technology**
  - Compatible with 0.5  $\mu$ m Am29F080 device
- **High performance**
  - Access times as fast as 70 ns
- **Low power consumption**
  - 25 mA typical active read current
  - 30 mA typical program/erase current
  - 1  $\mu$ A typical standby current (standard access time to active mode)
- **Flexible sector architecture**
  - 16 uniform sectors of 64 Kbytes each
  - Any combination of sectors can be erased.
  - Supports full chip erase
  - Group sector protection:
    - A hardware method of locking sector groups to prevent any program or erase operations within that sector group
    - Temporary Sector Group Unprotect allows code changes in previously locked sectors
- **Embedded Algorithms**
  - Embedded Erase algorithm automatically preprograms and erases the entire chip or any combination of designated sectors
  - Embedded Program algorithm automatically writes and verifies bytes at specified addresses
- **Minimum 1,000,000 program/erase cycles per sector guaranteed**
- **Package options**
  - 40-pin TSOP
  - 44-pin SO
- **Compatible with JEDEC standards**
  - Pinout and software compatible with single-power-supply Flash standard
  - Superior inadvertent write protection
- **Data# Polling and toggle bits**
  - Provides a software method of detecting program or erase cycle completion
- **Ready/Busy# output (RY/BY#)**
  - Provides a hardware method for detecting program or erase cycle completion
- **Erase Suspend/Erase Resume**
  - Suspends a sector erase operation to read data from, or program data to, a non-erasing sector, then resumes the erase operation
- **Hardware reset pin (RESET#)**
  - Resets internal state machine to the read mode

## GENERAL DESCRIPTION

The Am29F080B is an 8 Mbit, 5.0 volt-only Flash memory organized as 1,048,576 bytes. The 8 bits of data appear on DQ0–DQ7. The Am29F080B is offered in 40-pin TSOP and 44-pin SO packages. This device is designed to be programmed in-system with the standard system 5.0 volt  $V_{CC}$  supply. A 12.0 volt  $V_{PP}$  is not required for program or erase operations. The device can also be programmed in standard EPROM programmers.

This device is manufactured using AMD's 0.35  $\mu\text{m}$  process technology, and offers all the features and benefits of the Am29F080, which was manufactured using 0.5  $\mu\text{m}$  process technology.

The standard device offers access times of 70, 90, 120, and 150 ns, allowing high-speed microprocessors to operate without wait states. To eliminate bus contention, the device has separate chip enable (CE#), write enable (WE#), and output enable (OE#) controls.

The device requires only a **single 5.0 volt power supply** for both read and write functions. Internally generated and regulated voltages are provided for the program and erase operations.

The device is entirely command set compatible with the **JEDEC single-power-supply Flash standard**. Commands are written to the command register using standard microprocessor write timings. Register contents serve as input to an internal state-machine that controls the erase and programming circuitry. Write cycles also internally latch addresses and data needed for the programming and erase operations. Reading data out of the device is similar to reading from other Flash or EPROM devices.

Device programming occurs by executing the program command sequence. This initiates the **Embedded Program** algorithm—an internal algorithm that automatically times the program pulse widths and verifies proper cell margin.

Device erasure occurs by executing the erase command sequence. This initiates the **Embedded Erase** algorithm—an internal algorithm that automatically preprograms the array (if it is not already programmed)

before executing the erase operation. During erase, the device automatically times the erase pulse widths and verifies proper cell margin.

The host system can detect whether a program or erase operation is complete by observing the RY/BY# pin, or by reading the DQ7 (Data# Polling) and DQ6 (toggle) **status bits**. After a program or erase cycle has been completed, the device is ready to read array data or accept another command.

The **sector erase architecture** allows memory sectors to be erased and reprogrammed without affecting the data contents of other sectors. The device is fully erased when shipped from the factory.

**Hardware data protection** measures include a low  $V_{CC}$  detector that automatically inhibits write operations during power transitions. The **hardware sector protection** feature disables both program and erase operations in any combination of the sectors of memory. This can be achieved via programming equipment.

The **Erase Suspend** feature enables the user to put erase on hold for any period of time to read data from, or program data to, any sector that is not selected for erasure. True background erase can thus be achieved.

The **hardware RESET# pin** terminates any operation in progress and resets the internal state machine to reading array data. The RESET# pin may be tied to the system reset circuitry. A system reset would thus also reset the device, enabling the system microprocessor to read the boot-up firmware from the Flash memory.

The system can place the device into the **standby mode**. Power consumption is greatly reduced in this mode.

AMD's Flash technology combines years of Flash memory manufacturing experience to produce the highest levels of quality, reliability and cost effectiveness. The device electrically erases all bits within a sector simultaneously via Fowler-Nordheim tunneling. The data is programmed using hot electron injection.

### PRODUCT SELECTOR GUIDE

Family Part Number		Am29F080B			
Speed Option	V <sub>CC</sub> = 5.0 V ± 5%	-75			
	V <sub>CC</sub> = 5.0 V ± 10%		-90	-120	-150
Max Access Time, ns (t <sub>ACC</sub> )		70	90	120	150
Max CE# Access, ns (t <sub>CE</sub> )		70	90	120	150
Max OE# Access, ns (t <sub>OE</sub> )		40	40	50	75

**Note:** See the "AC Characteristics" section for more information.

### BLOCK DIAGRAM

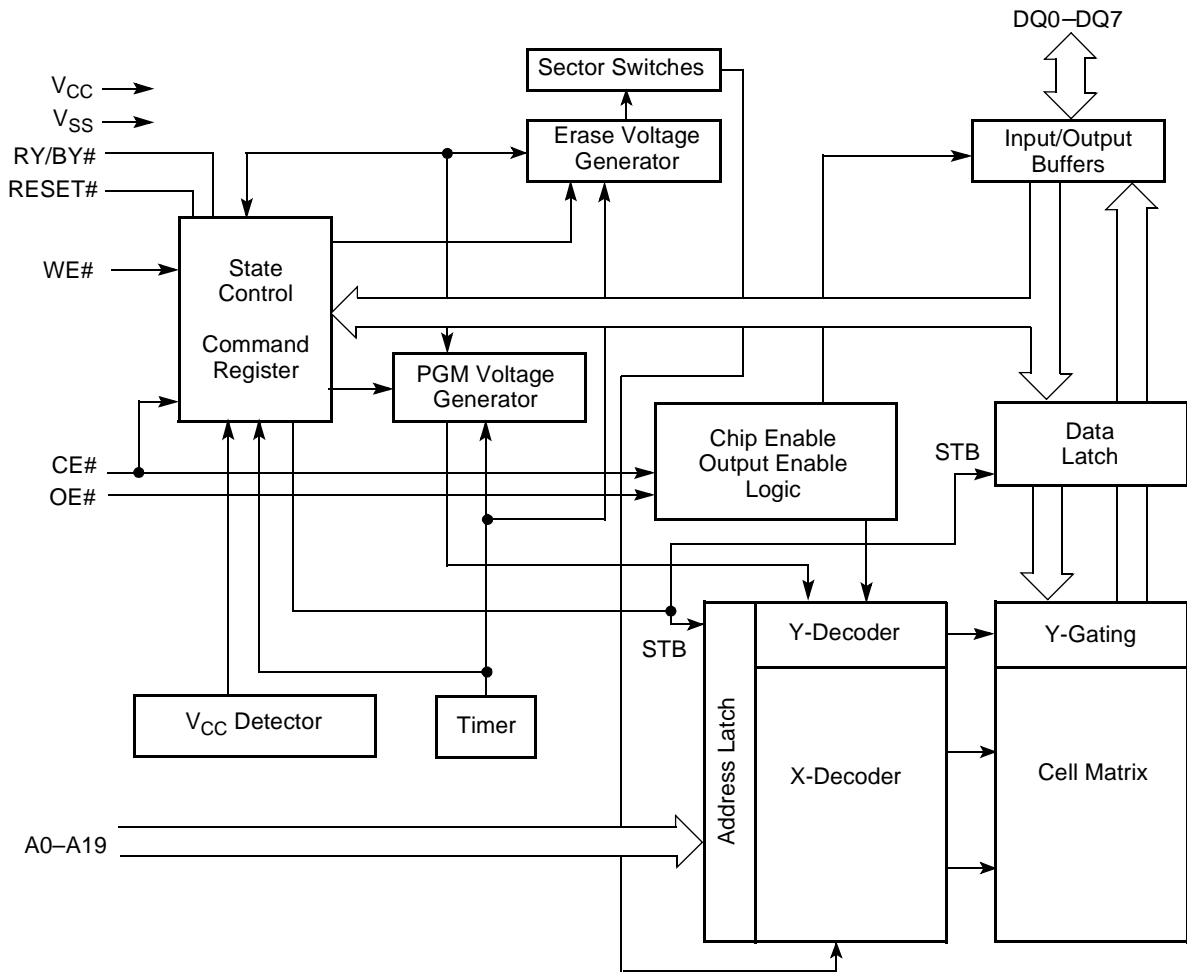

21503C-1

CONNECTION DIAGRAMS

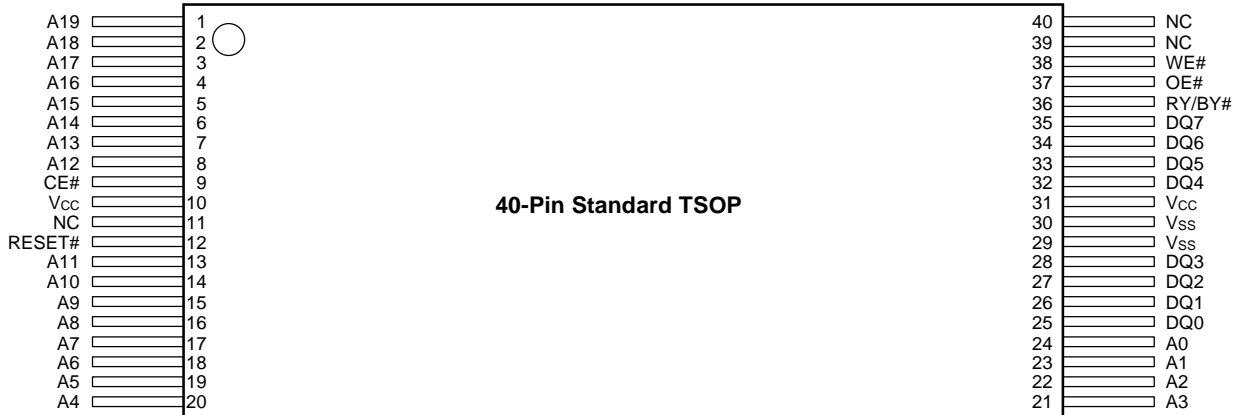

21503C-2

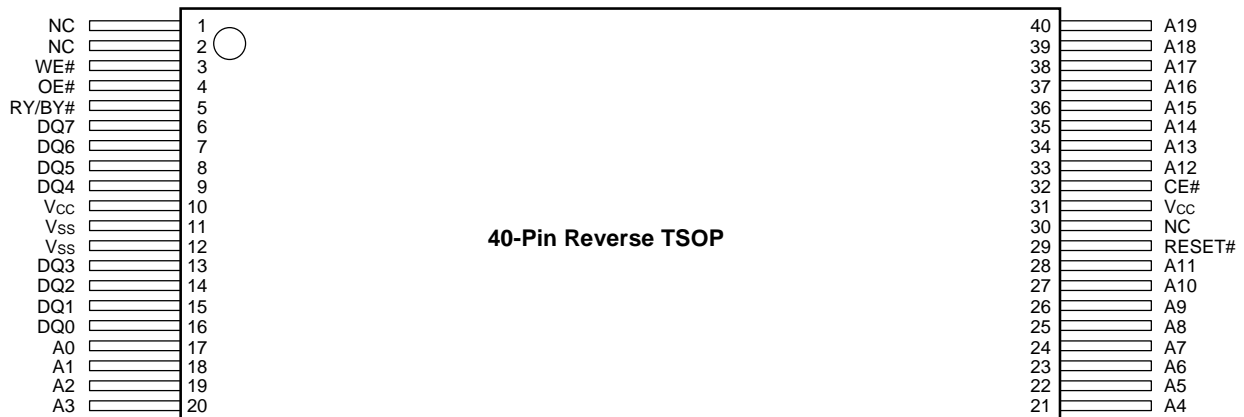

21503C-3

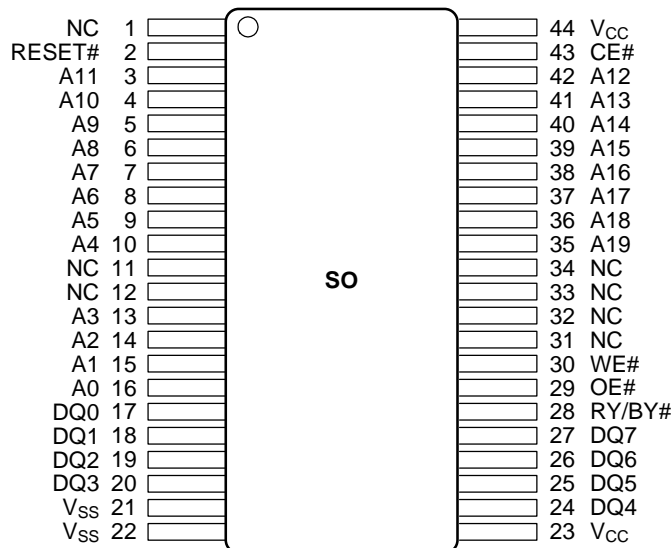

21503C-4

**PIN CONFIGURATION**

- A0–A19 = 20 Addresses
- DQ0–DQ7 = 8 Data Inputs/Outputs
- CE# = Chip Enable
- WE# = Write Enable
- OE# = Output Enable
- RESET# = Hardware Reset Pin, Active Low
- RY/BY# = Ready/Busy Output
- V<sub>CC</sub> = +5.0 V single power supply  
(see Product Selector Guide for device speed ratings and voltage supply tolerances)
- V<sub>SS</sub> = Device Ground
- NC = Pin Not Connected Internally

**LOGIC SYMBOL**

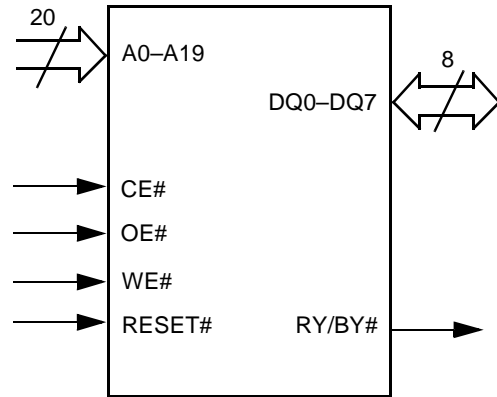

21503C-5

**ORDERING INFORMATION**

**Standard Products**

AMD standard products are available in several packages and operating ranges. The order number (Valid Combination) is formed by a combination of the following:

**Am29F080B**

**-75**

**E**

**I**

**OPTIONAL PROCESSING**

Blank = Standard Processing

B = Burn-In

Contact an AMD representative for more information.

**TEMPERATURE RANGE**

C = Commercial (0°C to +70°C)

I = Industrial (-40°C to +85°C)

**PACKAGE TYPE**

E = 40-Pin Thin Small Outline Package (TSOP) Standard Pinout (TS 040)

F = 40-Pin Thin Small Outline Package (TSOP) Reverse Pinout (TSR040)

S = 44-Pin Small Outline Package (SO 044)

**SPEED OPTION**

See Product Selector Guide and Valid Combinations

**DEVICE NUMBER/DESCRIPTION**

Am29F080B

8 Megabit (1 M x 8-Bit) CMOS 5.0 Volt-only Sector Erase Flash Memory

5.0 V Read, Program, and Erase

Valid Combinations	
Am29F080B-75	EC, EI, FC, FI, SC, SI
Am29F080B-90	EC, EI, EE, FC, FI, FE, SC, SI, SE
Am29F080B-120	
Am29F080B-150	

**Valid Combinations**

Valid Combinations list configurations planned to be supported in volume for this device. Consult the local AMD sales office to confirm availability of specific valid combinations and to check on newly released combinations.

## DEVICE BUS OPERATIONS

This section describes the requirements and use of the device bus operations, which are initiated through the internal command register. The command register itself does not occupy any addressable memory location. The register is composed of latches that store the commands, along with the address and data information needed to execute the command. The contents of

the register serve as inputs to the internal state machine. The state machine outputs dictate the function of the device. The appropriate device bus operations table lists the inputs and control levels required, and the resulting output. The following subsections describe each of these operations in further detail.

**Table 1. Am29F080B Device Bus Operations**

Operation	CE#	OE#	WE#	RESET#	A0–A19	DQ0–DQ7
Read	L	L	X	H	A <sub>IN</sub>	D <sub>OUT</sub>
Write	L	H	L	H	A <sub>IN</sub>	D <sub>IN</sub>
TTL Standby	H	X	X	H	X	HIGH Z
CMOS Standby	V <sub>CC</sub> ± 0.3 V	X	X	V <sub>CC</sub> ± 0.3 V	X	HIGH Z
Output Disable	L	H	H	H	X	HIGH Z
Hardware Reset	X	X	X	V <sub>IL</sub>	X	HIGH Z
Temporary Sector Group Unprotect (See Note)	X	X	X	V <sub>ID</sub>	A <sub>IN</sub>	X

**Legend:**

L = Logic Low = V<sub>IL</sub>, H = Logic High = V<sub>IH</sub>, D<sub>OUT</sub> = Data Out, D<sub>IN</sub> = Data In, A<sub>IN</sub> = Address In, X = Don't Care. See DC Characteristics for voltage levels.

**Note:** See the sections on Sector Group Protection and Temporary Sector Unprotect for more information.

### Requirements for Reading Array Data

To read array data from the outputs, the system must drive the CE# and OE# pins to V<sub>IL</sub>. CE# is the power control and selects the device. OE# is the output control and gates array data to the output pins. WE# should remain at V<sub>IH</sub>.

The internal state machine is set for reading array data upon device power-up, or after a hardware reset. This ensures that no spurious alteration of the memory content occurs during the power transition. No command is necessary in this mode to obtain array data. Standard microprocessor read cycles that assert valid addresses on the device address inputs produce valid data on the device data outputs. The device remains enabled for read access until the command register contents are altered.

See “Reading Array Data” for more information. Refer to the AC Read Operations table for timing specifications and to the Read Operations Timings diagram for the timing waveforms. I<sub>CC1</sub> in the DC Characteristics table represents the active current specification for reading array data.

### Writing Commands/Command Sequences

To write a command or command sequence (which includes programming data to the device and erasing sectors of memory), the system must drive WE# and CE# to V<sub>IL</sub>, and OE# to V<sub>IH</sub>.

An erase operation can erase one sector, multiple sectors, or the entire device. The Sector Address Tables indicate the address space that each sector occupies. A “sector address” consists of the address bits required to uniquely select a sector. See the Command Definitions section for details on erasing a sector or the entire chip, or suspending/resuming the erase operation.

After the system writes the autoselect command sequence, the device enters the autoselect mode. The system can then read autoselect codes from the internal register (which is separate from the memory array) on DQ7–DQ0. Standard read cycle timings apply in this mode. Refer to the Autoselect Mode and Autoselect Command Sequence sections for more information.

I<sub>CC2</sub> in the DC Characteristics table represents the active current specification for the write mode. The “AC Characteristics” section contains timing specification tables and timing diagrams for write operations.

## Program and Erase Operation Status

During an erase or program operation, the system may check the status of the operation by reading the status bits on DQ7–DQ0. Standard read cycle timings and  $I_{CC}$  read specifications apply. Refer to “Write Operation Status” for more information, and to each AC Characteristics section in the appropriate data sheet for timing diagrams.

## Standby Mode

When the system is not reading or writing to the device, it can place the device in the standby mode. In this mode, current consumption is greatly reduced, and the outputs are placed in the high impedance state, independent of the OE# input.

The device enters the CMOS standby mode when CE# and RESET# pins are both held at  $V_{CC} \pm 0.5$  V. (Note that this is a more restricted voltage range than  $V_{IH}$ .) The device enters the TTL standby mode when CE# and RESET# pins are both held at  $V_{IH}$ . The device requires standard access time ( $t_{CE}$ ) for read access when the device is in either of these standby modes, before it is ready to read data.

The device also enters the standby mode when the RESET# pin is driven low. Refer to the next section, “RESET#: Hardware Reset Pin”.

If the device is deselected during erasure or programming, the device draws active current until the operation is completed.

In the DC Characteristics tables,  $I_{CC3}$  represents the standby current specification.

## RESET#: Hardware Reset Pin

The RESET# pin provides a hardware method of resetting the device to reading array data. When the system

drives the RESET# pin low for at least a period of  $t_{RP}$  the device **immediately terminates** any operation in progress, tristates all data output pins, and ignores all read/write attempts for the duration of the RESET# pulse. The device also resets the internal state machine to reading array data. The operation that was interrupted should be reinitiated once the device is ready to accept another command sequence, to ensure data integrity.

Current is reduced for the duration of the RESET# pulse. When RESET# is held at  $V_{IL}$ , the device enters the TTL standby mode; if RESET# is held at  $V_{SS} \pm 0.5$  V, the device enters the CMOS standby mode.

The RESET# pin may be tied to the system reset circuitry. A system reset would thus also reset the Flash memory, enabling the system to read the boot-up firmware from the Flash memory.

If RESET# is asserted during a program or erase operation, the RY/BY# pin remains a “0” (busy) until the internal reset operation is complete, which requires a time of  $t_{READY}$  (during Embedded Algorithms). The system can thus monitor RY/BY# to determine whether the reset operation is complete. If RESET# is asserted when a program or erase operation is not executing (RY/BY# pin is “1”), the reset operation is completed within a time of  $t_{READY}$  (not during Embedded Algorithms). The system can read data  $t_{RH}$  after the RESET# pin returns to  $V_{IH}$ .

Refer to the AC Characteristics tables for RESET# parameters and timing diagram.

## Output Disable Mode

When the OE# input is at  $V_{IH}$ , output from the device is disabled. The output pins are placed in the high impedance state.

Table 2. Am29F080B Sector Address Table

Sector	A19	A18	A17	A16	Address Range
SA0	0	0	0	0	000000h–00FFFFh
SA1	0	0	0	1	010000h–01FFFFh
SA2	0	0	1	0	020000h–02FFFFh
SA3	0	0	1	1	030000h–03FFFFh
SA4	0	1	0	0	040000h–04FFFFh
SA5	0	1	0	1	050000h–05FFFFh
SA6	0	1	1	0	060000h–06FFFFh
SA7	0	1	1	1	070000h–07FFFFh
SA8	1	0	0	0	080000h–08FFFFh
SA9	1	0	0	1	090000h–09FFFFh
SA10	1	0	1	0	0A0000h–0AFFFFh
SA11	1	0	1	1	0B0000h–0BFFFFh
SA12	1	1	0	0	0C0000h–0CFFFFh
SA13	1	1	0	1	0D0000h–0DFFFFh
SA14	1	1	1	0	0E0000h–0EFFFFh
SA15	1	1	1	1	0F0000h–0FFFFFh

**Note:** All sectors are 64 Kbytes in size.

## Autoselect Mode

The autoselect mode provides manufacturer and device identification, and sector protection verification, through identifier codes output on DQ7–DQ0. This mode is primarily intended for programming equipment to automatically match a device to be programmed with its corresponding programming algorithm. However, the autoselect codes can also be accessed in-system through the command register.

When using programming equipment, the autoselect mode requires  $V_{ID}$  (11.5 V to 12.5 V) on address pin A9. Address pins A6, A1, and A0 must be as shown in Autoselect Codes (High Voltage Method) table. In addition, when verifying sector protection, the sector ad-

dress must appear on the appropriate highest order address bits. Refer to the corresponding Sector Address Tables. The Command Definitions table shows the remaining address bits that are don't care. When all necessary bits have been set as required, the programming equipment may then read the corresponding identifier code on DQ7–DQ0.

To access the autoselect codes in-system, the host system can issue the autoselect command via the command register, as shown in the Command Definitions table. This method does not require  $V_{ID}$ . See "Command Definitions" for details on using the autoselect mode.

**Table 3. Am29F080B Autoselect Codes (High Voltage Method)**

Description	CE#	OE#	WE#	A19 to A12	A11 to A10	A9	A8 to A7	A6	A5 to A2	A1	A0	DQ7 to DQ0
Manufacturer ID: AMD	L	L	H	X	X	V <sub>ID</sub>	X	L	X	L	L	01h
Device ID: Am29F080B	L	L	H	X	X	V <sub>ID</sub>	X	L	X	L	H	D5h
Sector Group Protection Verification	L	L	H	SGA	X	V <sub>ID</sub>	X	L	X	H	L	01h (protected)
												00h (unprotected)

**Legend:** L = Logic Low = V<sub>IL</sub>, H = Logic High = V<sub>IH</sub>, SGA = Sector Group Address, X = Don't care.

**Note:** The system may also autoselect information in-system via the command register. See Table 5.

### Sector Group Protection/Unprotection

The hardware group sector protection feature disables both program and erase operations in any sector group. Each sector group consists of two adjacent sectors. Table 4 shows how the sectors are grouped, and the address range that each sector group contains. The hardware sector group unprotection feature re-enables both program and erase operations in previously protected sector groups.

Sector group protection/unprotection must be implemented using programming equipment. The procedure requires a high voltage (V<sub>ID</sub>) on address pin A9 and the control pins. Details on this method are provided in a supplement, listed in publication number 19945. Contact an AMD representative to obtain a copy of the appropriate document.

The device is shipped with all sectors unprotected. AMD offers the option of programming and protecting sector groups at its factory prior to shipping the device through AMD's ExpressFlash™ Service. Contact an AMD representative for details.

It is possible to determine whether a sector group is protected or unprotected. See "Autoselect Mode" for details.

**Table 4. Sector Group Addresses**

Sector Group	A19	A18	A17	Sectors
SGA0	0	0	0	SA0–SA1
SGA1	0	0	1	SA2–SA3
SGA2	0	1	0	SA4–SA5
SGA3	0	1	1	SA6–SA7
SGA4	1	0	0	SA8–SA9
SGA5	1	0	1	SA10–SA11
SGA6	1	1	0	SA12–SA13
SGA7	1	1	1	SA14–SA15

### Temporary Sector Group Unprotect

This feature allows temporary unprotection of previously protected sector groups to change data in-system. The Sector Group Unprotect mode is activated by setting the RESET# pin to V<sub>ID</sub>. During this mode, formerly protected sector groups can be programmed or erased by selecting the sector group addresses. Once V<sub>ID</sub> is removed from the RESET# pin, all the previously protected sector groups are protected again. Figure 1 shows the algorithm, and the Temporary Sector Group Unprotect diagram shows the timing waveforms, for this feature.

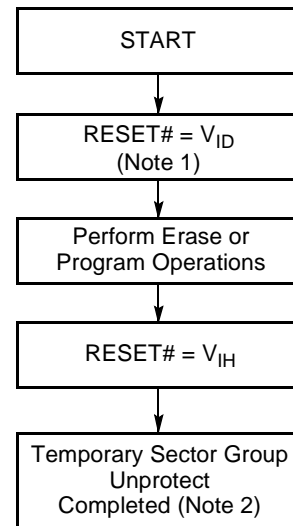

21503C-6

**Notes:**

1. All protected sector groups unprotected.
2. All previously protected sector groups are protected once again.

**Figure 1. Temporary Sector Group Unprotect Operation**

## Hardware Data Protection

The command sequence requirement of unlock cycles for programming or erasing provides data protection against inadvertent writes (refer to the Command Definitions table). In addition, the following hardware data protection measures prevent accidental erasure or programming, which might otherwise be caused by spurious system level signals during  $V_{CC}$  power-up and power-down transitions, or from system noise.

### Low $V_{CC}$ Write Inhibit

When  $V_{CC}$  is less than  $V_{LKO}$ , the device does not accept any write cycles. This protects data during  $V_{CC}$  power-up and power-down. The command register and all internal program/erase circuits are disabled, and the device resets. Subsequent writes are ignored until  $V_{CC}$  is greater than  $V_{LKO}$ . The system must provide the

proper signals to the control pins to prevent unintentional writes when  $V_{CC}$  is greater than  $V_{LKO}$ .

### Write Pulse “Glitch” Protection

Noise pulses of less than 5 ns (typical) on OE#, CE# or WE# do not initiate a write cycle.

### Logical Inhibit

Write cycles are inhibited by holding any one of OE# =  $V_{IL}$ , CE# =  $V_{IH}$  or WE# =  $V_{IH}$ . To initiate a write cycle, CE# and WE# must be a logical zero while OE# is a logical one.

### Power-Up Write Inhibit

If WE# = CE# =  $V_{IL}$  and OE# =  $V_{IH}$  during power up, the device does not accept commands on the rising edge of WE#. The internal state machine is automatically reset to reading array data on power-up.

## COMMAND DEFINITIONS

Writing specific address and data commands or sequences into the command register initiates device operations. The Command Definitions table defines the valid register command sequences. Writing **incorrect address and data values** or writing them in the **improper sequence** resets the device to reading array data.

All addresses are latched on the falling edge of WE# or CE#, whichever happens later. All data is latched on the rising edge of WE# or CE#, whichever happens first. Refer to the appropriate timing diagrams in the “AC Characteristics” section.

### Reading Array Data

The device is automatically set to reading array data after device power-up. No commands are required to retrieve data. The device is also ready to read array data after completing an Embedded Program or Embedded Erase algorithm.

After the device accepts an Erase Suspend command, the device enters the Erase Suspend mode. The system can read array data using the standard read timings, except that if it reads at an address within erase-suspended sectors, the device outputs status data. After completing a programming operation in the Erase Suspend mode, the system may once again read array data with the same exception. See “Erase Suspend/ Erase Resume Commands” for more information on this mode.

The system *must* issue the reset command to re-enable the device for reading array data if DQ5 goes high, or while in the autoselect mode. See the “Reset Command” section, next.

See also “Requirements for Reading Array Data” in the “Device Bus Operations” section for more information. The Read Operations table provides the read parameters, and Read Operation Timings diagram shows the timing diagram.

### Reset Command

Writing the reset command to the device resets the device to reading array data. Address bits are don't care for this command.

The reset command may be written between the sequence cycles in an erase command sequence before erasing begins. This resets the device to reading array data. Once erasure begins, however, the device ignores reset commands until the operation is complete.

The reset command may be written between the sequence cycles in a program command sequence before programming begins. This resets the device to reading array data (also applies to programming in Erase Suspend mode). Once programming begins,

however, the device ignores reset commands until the operation is complete.

The reset command may be written between the sequence cycles in an autoselect command sequence. Once in the autoselect mode, the reset command *must* be written to return to reading array data (also applies to autoselect during Erase Suspend).

If DQ5 goes high during a program or erase operation, writing the reset command returns the device to reading array data (also applies during Erase Suspend).

### Autoselect Command Sequence

The autoselect command sequence allows the host system to access the manufacturer and device codes, and determine whether or not a sector is protected. The Command Definitions table shows the address and data requirements. This method is an alternative to that shown in the Autoselect Codes (High Voltage Method) table, which is intended for PROM programmers and requires  $V_{ID}$  on address bit A9.

The autoselect command sequence is initiated by writing two unlock cycles, followed by the autoselect command. The device then enters the autoselect mode, and the system may read at any address any number of times, without initiating another command sequence.

A read cycle at address XX00h retrieves the manufacturer code. A read cycle at address XX01h returns the device code. A read cycle containing a sector address (SA) and the address 02h in returns 01h if that sector is protected, or 00h if it is unprotected. Refer to the Sector Address tables for valid sector addresses.

The system must write the reset command to exit the autoselect mode and return to reading array data.

### Byte Program Command Sequence

Programming is a four-bus-cycle operation. The program command sequence is initiated by writing two unlock write cycles, followed by the program set-up command. The program address and data are written next, which in turn initiate the Embedded Program algorithm. The system is *not* required to provide further controls or timings. The device automatically provides internally generated program pulses and verify the programmed cell margin. The Command Definitions table shows the address and data requirements for the byte program command sequence.

When the Embedded Program algorithm is complete, the device then returns to reading array data and addresses are no longer latched. The system can determine the status of the program operation by using DQ7, DQ6, or RY/BY#. See “Write Operation Status” for information on these status bits.

Any commands written to the device during the Embedded Program Algorithm are ignored. Note that a **hardware reset** immediately terminates the programming operation. The program command sequence should be reinitiated once the device has reset to reading array data, to ensure data integrity.

Programming is allowed in any sequence and across sector boundaries. **A bit cannot be programmed from a “0” back to a “1”**. Attempting to do so may halt the operation and set DQ5 to “1”, or cause the Data# Polling algorithm to indicate the operation was successful. However, a succeeding read will show that the data is still “0”. Only erase operations can convert a “0” to a “1”.

command, which in turn invokes the Embedded Erase algorithm. The device does *not* require the system to preprogram prior to erase. The Embedded Erase algorithm automatically preprograms and verifies the entire memory for an all zero data pattern prior to electrical erase. The system is not required to provide any controls or timings during these operations. The Command Definitions table shows the address and data requirements for the chip erase command sequence.

Any commands written to the chip during the Embedded Erase algorithm are ignored. Note that a **hardware reset** during the chip erase operation immediately terminates the operation. The Chip Erase command sequence should be reinitiated once the device has returned to reading array data, to ensure data integrity.

The system can determine the status of the erase operation by using DQ7, DQ6, DQ2, or RY/BY#. See “Write Operation Status” for information on these status bits. When the Embedded Erase algorithm is complete, the device returns to reading array data and addresses are no longer latched.

Figure 3 illustrates the algorithm for the erase operation. See the Erase/Program Operations tables in “AC Characteristics” for parameters, and to the Chip/Sector Erase Operation Timings for timing waveforms.

### Sector Erase Command Sequence

Sector erase is a six bus cycle operation. The sector erase command sequence is initiated by writing two unlock cycles, followed by a set-up command. Two additional unlock write cycles are then followed by the address of the sector to be erased, and the sector erase command. The Command Definitions table shows the address and data requirements for the sector erase command sequence.

The device does *not* require the system to preprogram the memory prior to erase. The Embedded Erase algorithm automatically programs and verifies the sector for an all zero data pattern prior to electrical erase. The system is not required to provide any controls or timings during these operations.

After the command sequence is written, a sector erase time-out of 50  $\mu$ s begins. During the time-out period, additional sector addresses and sector erase commands may be written. Loading the sector erase buffer may be done in any sequence, and the number of sectors may be from one sector to all sectors. The time between these additional cycles must be less than 50  $\mu$ s, otherwise the last address and command might not be accepted, and erasure may begin. It is recommended that processor interrupts be disabled during this time to ensure all commands are accepted. The interrupts can be re-enabled after the last Sector Erase command is written. If the time between additional sector erase commands can be assumed to be less than 50  $\mu$ s, the system need not monitor DQ3. **Any command other**

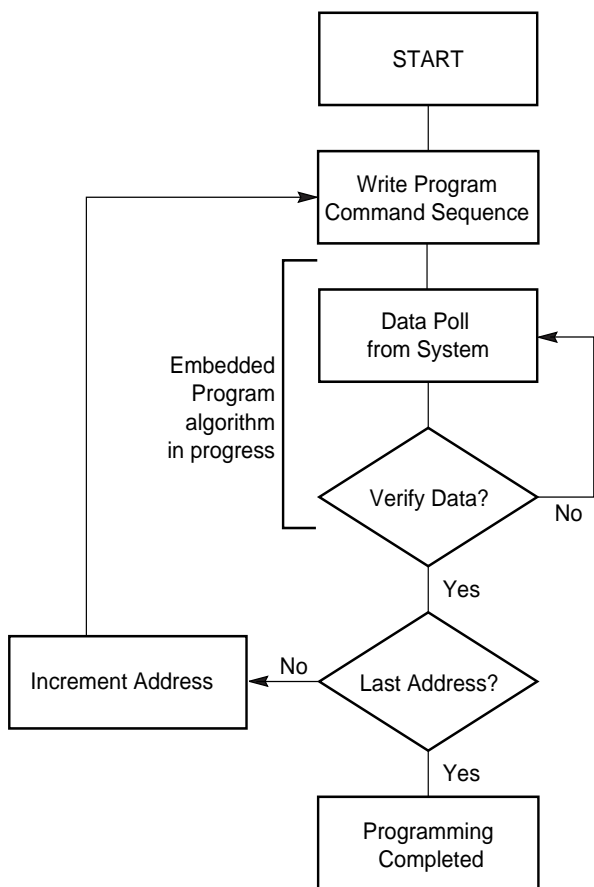

21503C-7

**Note:** See the appropriate Command Definitions table for program command sequence.

**Figure 2. Program Operation**

### Chip Erase Command Sequence

Chip erase is a six-bus-cycle operation. The chip erase command sequence is initiated by writing two unlock cycles, followed by a set-up command. Two additional unlock write cycles are then followed by the chip erase

than Sector Erase or Erase Suspend during the time-out period resets the device to reading array data. The system must rewrite the command sequence and any additional sector addresses and commands.

The system can monitor DQ3 to determine if the sector erase timer has timed out. (See the “DQ3: Sector Erase Timer” section.) The time-out begins from the rising edge of the final WE# pulse in the command sequence.

Once the sector erase operation has begun, only the Erase Suspend command is valid. All other commands are ignored. Note that a **hardware reset** during the sector erase operation immediately terminates the operation. The Sector Erase command sequence should be reinitiated once the device has returned to reading array data, to ensure data integrity.

When the Embedded Erase algorithm is complete, the device returns to reading array data and addresses are no longer latched. The system can determine the status of the erase operation by using DQ7, DQ6, DQ2, or RY/BY#. Refer to “Write Operation Status” for information on these status bits.

Figure 3 illustrates the algorithm for the erase operation. Refer to the Erase/Program Operations tables in the “AC Characteristics” section for parameters, and to the Sector Erase Operations Timing diagram for timing waveforms.

### Erase Suspend/Erase Resume Commands

The Erase Suspend command allows the system to interrupt a sector erase operation and then read data from, or program data to, any sector not selected for erasure. This command is valid only during the sector erase operation, including the 50  $\mu$ s time-out period during the sector erase command sequence. The Erase Suspend command is ignored if written during the chip erase operation or Embedded Program algorithm. Writing the Erase Suspend command during the Sector Erase time-out immediately terminates the time-out period and suspends the erase operation. Addresses are “don’t-cares” when writing the Erase Suspend command.

When the Erase Suspend command is written during a sector erase operation, the device requires a maximum of 20  $\mu$ s to suspend the erase operation. However, when the Erase Suspend command is written during the sector erase time-out, the device immediately terminates the time-out period and suspends the erase operation.

After the erase operation has been suspended, the system can read array data from or program data to any sector not selected for erasure. (The device “erase suspends” all sectors selected for erasure.) Normal read and write timings and command definitions apply. Reading at any address within erase-suspended sectors produces status data on DQ7–DQ0. The system can use DQ7, or DQ6 and DQ2 together, to determine if a sector is actively erasing or is erase-suspended. See “Write Operation Status” for information on these status bits.

After an erase-suspended program operation is complete, the system can once again read array data within non-suspended sectors. The system can determine the status of the program operation using the DQ7 or DQ6 status bits, just as in the standard program operation. See “Write Operation Status” for more information.

The system may also write the autoselect command sequence when the device is in the Erase Suspend mode. The device allows reading autoselect codes even at addresses within erasing sectors, since the codes are not stored in the memory array. When the device exits the autoselect mode, the device reverts to the Erase Suspend mode, and is ready for another valid operation. See “Autoselect Command Sequence” for more information.

The system must write the Erase Resume command (address bits are “don’t care”) to exit the erase suspend mode and continue the sector erase operation. Further writes of the Resume command are ignored. Another Erase Suspend command can be written after the device has resumed erasing.

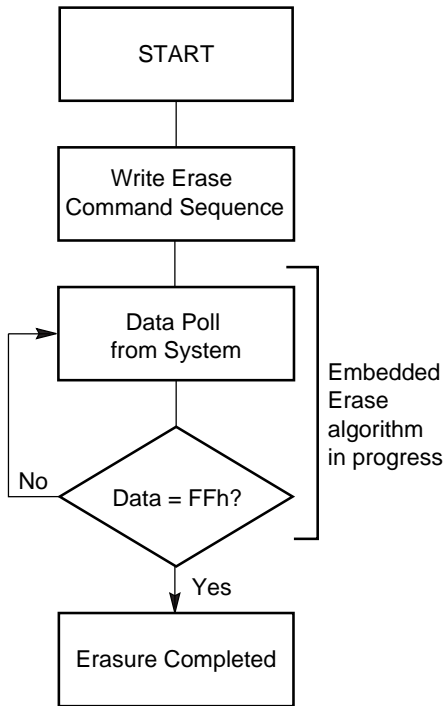

21503C-8

**Notes:**

1. See the appropriate *Command Definitions table for erase command sequence*.
2. See “DQ3: Sector Erase Timer” for more information.

**Figure 3. Erase Operation**

Table 5. Am29F080B Command Definitions

Command Sequence (Note 1)	Cycles	Bus Cycles (Notes 2–5)											
		First		Second		Third		Fourth		Fifth		Sixth	
		Addr	Data	Addr	Data	Addr	Data	Addr	Data	Addr	Data	Addr	Data
Read (Note 3)	1	RA	RD										
Reset (Note 4)	1	XXX	F0										
Autoselect Manufacturer ID	4	555	AA	2AA	55	555	90	X00	01				
Autoselect Device ID	4	555	AA	2AA	55	555	90	X01	D5				
Autoselect Sector Group Protect Verify (Note 5)	4	555	AA	2AA	55	555	90	SGA X02	00				
									01				
Byte Program	4	555	AA	2AA	55	555	A0	PA	PD				
Chip Erase	6	555	AA	2AA	55	555	80	555	AA	2AA	55	555	10
Sector Erase	6	555	AA	2AA	55	555	80	555	AA	2AA	55	SA	30
Erase Suspend (Note 6)	1	XXX	B0										
Erase Resume (Note 7)	1	XXX	30										

**Legend:**

RA = Address of the memory location to be read.

RD = Data read from location RA during read operation.

PA = Address of the memory location to be programmed. Addresses are latched on the falling edge of the WE# or CE# pulse.

PD = Data to be programmed at location PA. Data is latched on the rising edge of WE# or CE# pulse.

SA = Address of the sector to be erased. Address bits A19–A16 uniquely select any sector.

SGA = Address of the sector group to be verified.

**Notes:**

- All values are in hexadecimal.
- See Table 1 for descriptions of bus operations.
- No unlock or command cycles required when device is in read mode.
- The Reset command is required to return to the read mode when the device is in the autoselect mode or if DQ5 goes high.
- The data is 00h for an unprotected sector group and 01h for a protected sector group. The complete bus address in the fourth cycle is composed of the sector group address (A19–A17), A1 = 1, and A0 = 0.
- Read and program functions in non-erasing sectors are allowed in the Erase Suspend mode. The Erase Suspend command is valid only during a sector erase operation.
- The Erase Resume command is valid only during the Erase Suspend mode.
- Unless otherwise noted, address bits A19–A11 are don't care.

## WRITE OPERATION STATUS

The device provides several bits to determine the status of a write operation: DQ2, DQ3, DQ5, DQ6, DQ7, and RY/BY#. Table 6 and the following subsections describe the functions of these bits. DQ7, RY/BY#, and DQ6 each offer a method for determining whether a program or erase operation is complete or in progress. These three bits are discussed first.

### DQ7: Data# Polling

The Data# Polling bit, DQ7, indicates to the host system whether an Embedded Algorithm is in progress or completed, or whether the device is in Erase Suspend. Data# Polling is valid after the rising edge of the final WE# pulse in the program or erase command sequence.

During the Embedded Program algorithm, the device outputs on DQ7 the complement of the datum programmed to DQ7. This DQ7 status also applies to programming during Erase Suspend. When the Embedded Program algorithm is complete, the device outputs the datum programmed to DQ7. The system must provide the program address to read valid status information on DQ7. If a program address falls within a protected sector, Data# Polling on DQ7 is active for approximately 2  $\mu$ s, then the device returns to reading array data.

During the Embedded Erase algorithm, Data# Polling produces a "0" on DQ7. When the Embedded Erase algorithm is complete, or if the device enters the Erase Suspend mode, Data# Polling produces a "1" on DQ7. This is analogous to the complement/true datum output described for the Embedded Program algorithm: the erase function changes all the bits in a sector to "1"; prior to this, the device outputs the "complement," or "0." The system must provide an address within any of the sectors selected for erasure to read valid status information on DQ7.

After an erase command sequence is written, if all sectors selected for erasing are protected, Data# Polling on DQ7 is active for approximately 100  $\mu$ s, then the device returns to reading array data. If not all selected sectors are protected, the Embedded Erase algorithm erases the unprotected sectors, and ignores the selected sectors that are protected.

When the system detects DQ7 has changed from the complement to true data, it can read valid data at DQ7–DQ0 on the *following* read cycles. This is because DQ7 may change asynchronously with DQ0–DQ6 while Output Enable (OE#) is asserted low. The Data# Polling Timings (During Embedded Algorithms) figure in the "AC Characteristics" section illustrates this.

Table 6 shows the outputs for Data# Polling on DQ7. Figure 4 shows the Data# Polling algorithm.

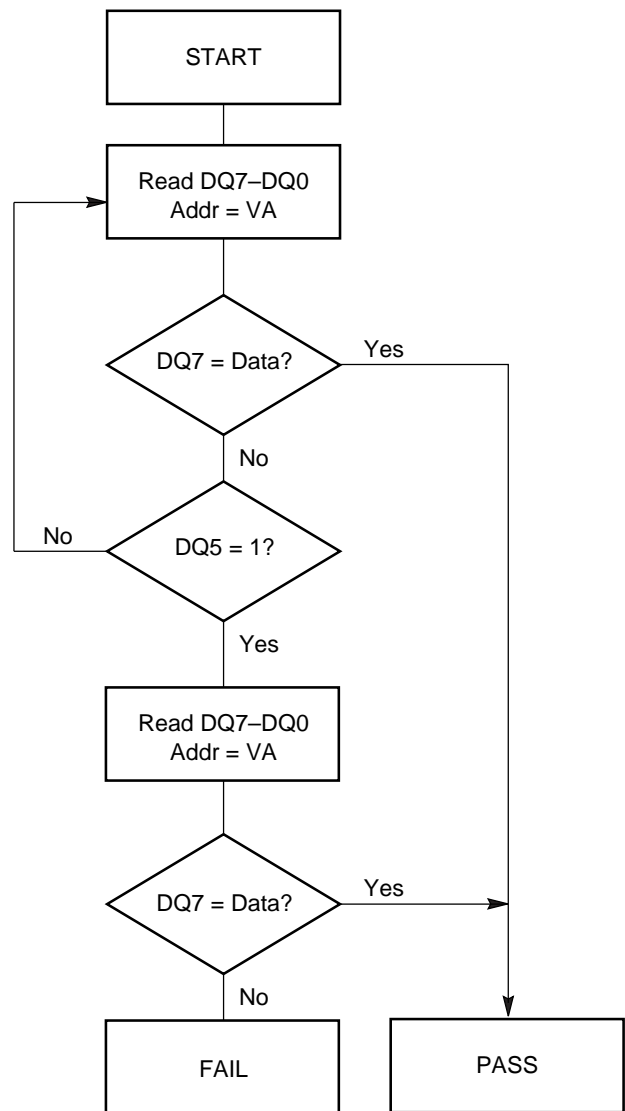

**Notes:**

1. VA = Valid address for programming. During a sector erase operation, a valid address is an address within any sector selected for erasure. During chip erase, a valid address is any non-protected sector address.
2. DQ7 should be rechecked even if DQ5 = "1" because DQ7 may change simultaneously with DQ5.

21503C-9

**Figure 4. Data# Polling Algorithm**

## **RY/BY#: Ready/Busy#**

The RY/BY# is a dedicated, open-drain output pin that indicates whether an Embedded Algorithm is in progress or complete. The RY/BY# status is valid after the rising edge of the final WE# pulse in the command sequence. Since RY/BY# is an open-drain output, several RY/BY# pins can be tied together in parallel with a pull-up resistor to  $V_{CC}$ .

If the output is low (Busy), the device is actively erasing or programming. (This includes programming in the Erase Suspend mode.) If the output is high (Ready), the device is ready to read array data (including during the Erase Suspend mode), or is in the standby mode.

Table 6 shows the outputs for RY/BY#. The timing diagrams for read, reset, program, and erase shows the relationship of RY/BY# to other signals.

## **DQ6: Toggle Bit I**

Toggle Bit I on DQ6 indicates whether an Embedded Program or Erase algorithm is in progress or complete, or whether the device has entered the Erase Suspend mode. Toggle Bit I may be read at any address, and is valid after the rising edge of the final WE# pulse in the command sequence (prior to the program or erase operation), and during the sector erase time-out.

During an Embedded Program or Erase algorithm operation, successive read cycles to any address cause DQ6 to toggle. (The system may use either OE# or CE# to control the read cycles.) When the operation is complete, DQ6 stops toggling.

After an erase command sequence is written, if all sectors selected for erasing are protected, DQ6 toggles for approximately 100  $\mu$ s, then returns to reading array data. If not all selected sectors are protected, the Embedded Erase algorithm erases the unprotected sectors, and ignores the selected sectors that are protected.

The system can use DQ6 and DQ2 together to determine whether a sector is actively erasing or is erase-suspended. When the device is actively erasing (that is, the Embedded Erase algorithm is in progress), DQ6 toggles. When the device enters the Erase Suspend mode, DQ6 stops toggling. However, the system must also use DQ2 to determine which sectors are erasing or erase-suspended. Alternatively, the system can use DQ7 (see the subsection on DQ7: Data# Polling).

If a program address falls within a protected sector, DQ6 toggles for approximately 2  $\mu$ s after the program command sequence is written, then returns to reading array data.

DQ6 also toggles during the erase-suspend-program mode, and stops toggling once the Embedded Program algorithm is complete.

The Write Operation Status table shows the outputs for Toggle Bit I on DQ6. Refer to Figure 5 for the toggle bit algorithm, and to the Toggle Bit Timings figure in the “AC Characteristics” section for the timing diagram. The DQ2 vs. DQ6 figure shows the differences between DQ2 and DQ6 in graphical form. See also the subsection on DQ2: Toggle Bit II.

## **DQ2: Toggle Bit II**

The “Toggle Bit II” on DQ2, when used with DQ6, indicates whether a particular sector is actively erasing (that is, the Embedded Erase algorithm is in progress), or whether that sector is erase-suspended. Toggle Bit II is valid after the rising edge of the final WE# pulse in the command sequence.

DQ2 toggles when the system reads at addresses within those sectors that have been selected for erasure. (The system may use either OE# or CE# to control the read cycles.) But DQ2 cannot distinguish whether the sector is actively erasing or is erase-suspended. DQ6, by comparison, indicates whether the device is actively erasing, or is in Erase Suspend, but cannot distinguish which sectors are selected for erasure. Thus, both status bits are required for sector and mode information. Refer to Table 6 to compare outputs for DQ2 and DQ6.

Figure 5 shows the toggle bit algorithm in flowchart form, and the section “DQ2: Toggle Bit II” explains the algorithm. See also the DQ6: Toggle Bit I subsection. Refer to the Toggle Bit Timings figure for the toggle bit timing diagram. The DQ2 vs. DQ6 figure shows the differences between DQ2 and DQ6 in graphical form.

## **Reading Toggle Bits DQ6/DQ2**

Refer to Figure 5 for the following discussion. Whenever the system initially begins reading toggle bit status, it must read DQ7–DQ0 at least twice in a row to determine whether a toggle bit is toggling. Typically, a system would note and store the value of the toggle bit after the first read. After the second read, the system would compare the new value of the toggle bit with the first. If the toggle bit is not toggling, the device has completed the program or erase operation. The system can read array data on DQ7–DQ0 on the following read cycle.

However, if after the initial two read cycles, the system determines that the toggle bit is still toggling, the system also should note whether the value of DQ5 is high (see the section on DQ5). If it is, the system should then determine again whether the toggle bit is toggling, since the toggle bit may have stopped toggling just as DQ5 went high. If the toggle bit is no longer toggling, the device has successfully completed the program or erase operation. If it is still toggling, the device did not complete the operation successfully, and the system must write the reset command to return to reading array data.

The remaining scenario is that the system initially determines that the toggle bit is toggling and DQ5 has not gone high. The system may continue to monitor the toggle bit and DQ5 through successive read cycles, determining the status as described in the previous paragraph. Alternatively, it may choose to perform other system tasks. In this case, the system must start at the beginning of the algorithm when it returns to determine the status of the operation (top of Figure 5).

### DQ5: Exceeded Timing Limits

DQ5 indicates whether the program or erase time has exceeded a specified internal pulse count limit. Under these conditions DQ5 produces a “1.” This is a failure condition that indicates the program or erase cycle was not successfully completed.

The DQ5 failure condition may appear if the system tries to program a “1” to a location that is previously programmed to “0.” **Only an erase operation can change a “0” back to a “1.”** Under this condition, the device halts the operation, and when the operation has exceeded the timing limits, DQ5 produces a “1.”

Under both these conditions, the system must issue the reset command to return the device to reading array data.

### DQ3: Sector Erase Timer

After writing a sector erase command sequence, the system may read DQ3 to determine whether or not an erase operation has begun. (The sector erase timer does not apply to the chip erase command.) If additional sectors are selected for erasure, the entire time-out also applies after each additional sector erase command. When the time-out is complete, DQ3 switches from “0” to “1.” The system may ignore DQ3 if the system can guarantee that the time between additional sector erase commands will always be less than 50 μs. See also the “Sector Erase Command Sequence” section.

After the sector erase command sequence is written, the system should read the status on DQ7 (Data# Polling) or DQ6 (Toggle Bit I) to ensure the device has accepted the command sequence, and then read DQ3. If DQ3 is “1”, the internally controlled erase cycle has begun; all further commands (other than Erase Suspend) are ignored until the erase operation is complete. If DQ3 is “0”, the device will accept additional sector erase commands. To ensure the command has been accepted, the system software should check the status of DQ3 prior to and following each subsequent sector erase command. If DQ3 is high on the second status

check, the last command might not have been accepted. Table 6 shows the outputs for DQ3.

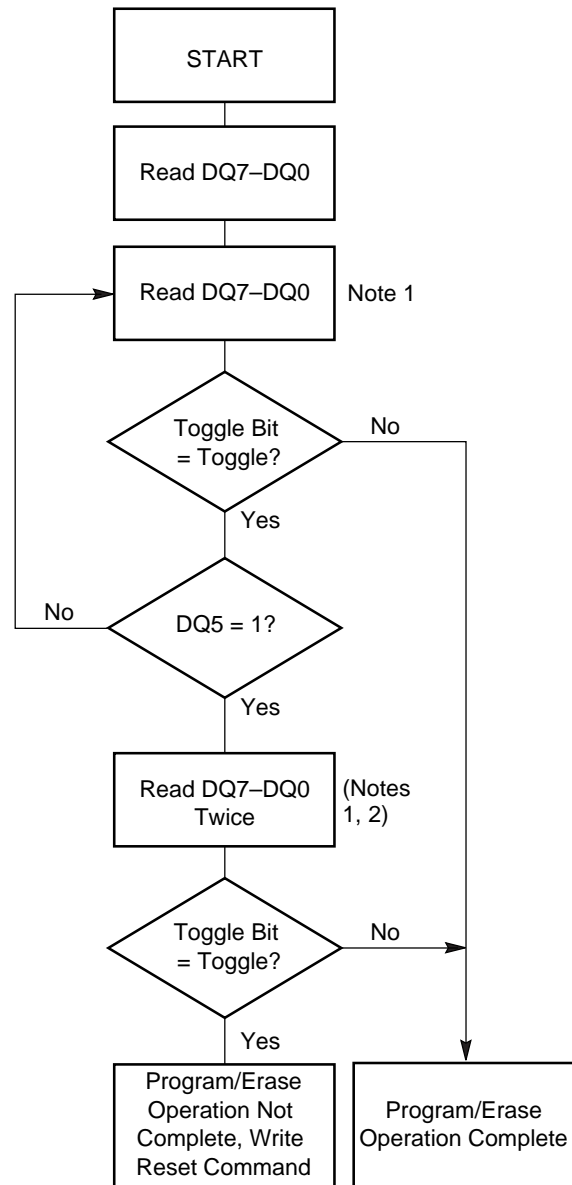

**Notes:**

1. Read toggle bit twice to determine whether or not it is toggling. See text.
2. Recheck toggle bit because it may stop toggling as DQ5 changes to “1”. See text.

21503C-10

**Figure 5. Toggle Bit Algorithm**

Table 6. Write Operation Status

Operation		DQ7 (Note 1)	DQ6	DQ5 (Note 2)	DQ3	DQ2 (Note 1)	RY/BY#
Standard Mode	Embedded Program Algorithm	DQ7#	Toggle	0	N/A	No toggle	0
	Embedded Erase Algorithm	0	Toggle	0	1	Toggle	0
Erase Suspend Mode	Reading within Erase Suspended Sector	1	No toggle	0	N/A	Toggle	1
	Reading within Non-Erase Suspended Sector	Data	Data	Data	Data	Data	1
	Erase-Suspend-Program	DQ7#	Toggle	0	N/A	N/A	0

**Notes:**

1. DQ7 and DQ2 require a valid address when reading status information. Refer to the appropriate subsection for further details.
2. DQ5 switches to '1' when an Embedded Program or Embedded Erase operation has exceeded the maximum timing limits. See "DQ5: Exceeded Timing Limits" for more information.

## ABSOLUTE MAXIMUM RATINGS

Storage Temperature	
Plastic Packages	..... -65°C to +125°C
Ambient Temperature	
with Power Applied	..... -55°C to +125°C
Voltage with Respect to Ground	
$V_{CC}$ (Note 1)	..... -2.0 V to +7.0 V
A9, OE#, RESET# (Note 2)	..... -2.0 V to +12.5 V
All other pins (Note 1)	..... -2.0 V to +7.0 V
Output Short Circuit Current (Note 3)	..... 200 mA

**Notes:**

1. Minimum DC voltage on input or I/O pins is -0.5 V. During voltage transitions, inputs may overshoot  $V_{SS}$  to -2.0 V for periods of up to 20 ns. See Figure 6. Maximum DC voltage on output and I/O pins is  $V_{CC} + 0.5$  V. During voltage transitions, outputs may overshoot to  $V_{CC} + 2.0$  V for periods up to 20 ns. See Figure 7.
2. Minimum DC input voltage on A9, OE#, RESET# pins is -0.5V. During voltage transitions, A9, OE#, RESET# pins may overshoot  $V_{SS}$  to -2.0 V for periods of up to 20 ns. See Figure 6. Maximum DC input voltage on A9, OE#, and RESET# is 12.5 V which may overshoot to 13.5 V for periods up to 20 ns.
3. No more than one output shorted at a time. Duration of the short circuit should not be greater than one second.

Stresses greater than those listed in this section may cause permanent damage to the device. This is a stress rating only; functional operation of the device at these or any other conditions above those indicated in the operational sections of this specification is not implied. Exposure of the device to absolute maximum rating conditions for extended periods may affect device reliability.

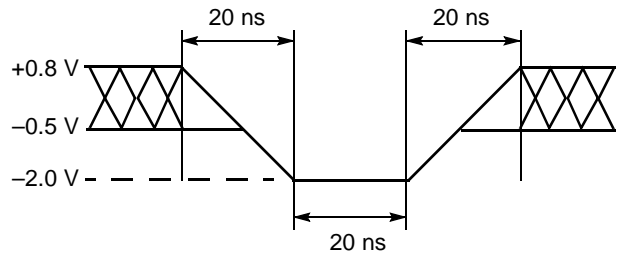

21503-11

**Figure 6. Maximum Negative Overshoot Waveform**

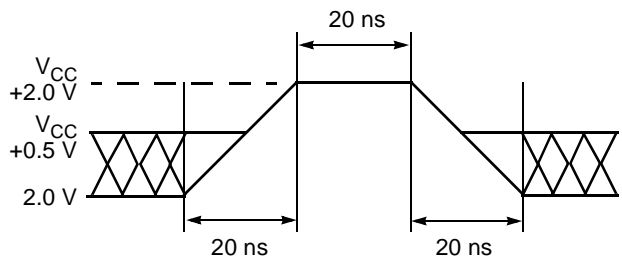

21503-12

**Figure 7. Maximum Negative Overshoot Waveform**

## OPERATING RANGES

**Commercial (C) Devices**

Case Temperature ( $T_C$ ) ..... 0°C to +70°C

**Industrial (I) Devices**

Case Temperature ( $T_C$ ) ..... -40°C to +85°C

**$V_{CC}$  Supply Voltages**

$V_{CC}$  for  $\pm$  5% devices ..... +4.75 V to +5.25 V

$V_{CC}$  for  $\pm$  10% devices ..... +4.5 V to +5.5 V

Operating ranges define those limits between which the functionality of the device is guaranteed.

## DC CHARACTERISTICS

## TTL/NMOS Compatible

Parameter Symbol	Parameter Description	Test Description	Min	Typ	Max	Unit
$I_{LI}$	Input Load Current	$V_{IN} = V_{SS}$ to $V_{CC}$ , $V_{CC} = V_{CC}$ Max			$\pm 1.0$	$\mu A$
$I_{LIT}$	A9 Input Load Current	$V_{CC} = V_{CC}$ Max, A9 = 12.5 V			50	$\mu A$
$I_{LO}$	Output Leakage Current	$V_{OUT} = V_{SS}$ to $V_{CC}$ , $V_{CC} = V_{CC}$ Max			$\pm 1.0$	$\mu A$
$I_{CC1}$	$V_{CC}$ Read Current (Note 1)	$CE\# = V_{IL}$ , $OE\# = V_{IH}$		25	40	mA
$I_{CC2}$	$V_{CC}$ Write Current (Notes 2, 3)	$CE\# = V_{IL}$ , $OE\# = V_{IH}$		40	60	mA
$I_{CC3}$	$V_{CC}$ Standby Current (CE# Controlled)	$V_{CC} = V_{CC}$ Max, $CE\# = V_{IH}$ , $RESET\# = V_{IH}$		0.4	1.0	mA
$I_{CC4}$	$V_{CC}$ Standby Current (RESET# Controlled)	$V_{CC} = V_{CC}$ Max, $RESET\# = V_{IL}$		0.4	1.0	mA
$V_{IL}$	Input Low Level		-0.5		0.8	V
$V_{IH}$	Input High Level		2.0		$V_{CC} + 0.5$	V
$V_{ID}$	Voltage for Autoselect and Sector Protect	$V_{CC} = 5.0$ V	11.5		12.5	V
$V_{OL}$	Output Low Voltage	$I_{OL} = 12$ mA, $V_{CC} = V_{CC}$ Min			0.45	V
$V_{OH}$	Output High Level	$I_{OH} = -2.5$ mA, $V_{CC} = V_{CC}$ Min	2.4			V
$V_{LKO}$	Low $V_{CC}$ Lock-out Voltage		3.2		4.2	V

## CMOS Compatible

Parameter Symbol	Parameter Description	Test Description	Min	Typ	Max	Unit
$I_{LI}$	Input Load Current	$V_{IN} = V_{SS}$ to $V_{CC}$ , $V_{CC} = V_{CC}$ Max			$\pm 1.0$	$\mu A$
$I_{LIT}$	A9 Input Load Current	$V_{CC} = V_{CC}$ Max, A9 = 12.5 V			50	$\mu A$
$I_{LO}$	Output Leakage Current	$V_{OUT} = V_{SS}$ to $V_{CC}$ , $V_{CC} = V_{CC}$ Max			$\pm 1.0$	$\mu A$
$I_{CC1}$	$V_{CC}$ Read Current (Note 1)	$CE\# = V_{IL}$ , $OE\# = V_{IH}$		25	40	mA
$I_{CC2}$	$V_{CC}$ Write Current (Notes 2, 3)	$CE\# = V_{IL}$ , $OE\# = V_{IH}$		30	40	mA
$I_{CC3}$	$V_{CC}$ Standby Current (CE# Controlled)	$V_{CC} = V_{CC}$ Max, $CE\# = V_{CC} \pm 0.3$ V, $RESET\# = V_{CC} \pm 0.3$ V		1	5	$\mu A$
$I_{CC4}$	$V_{CC}$ Standby Current (RESET# Controlled)	$V_{CC} = V_{CC}$ Max, $RESET\# = V_{SS} \pm 0.3$ V		1	5	$\mu A$
$V_{IL}$	Input Low Level		-0.5		0.8	V
$V_{IH}$	Input High Level		$0.7 \times V_{CC}$		$V_{CC} + 0.3$	V
$V_{ID}$	Voltage for Autoselect and Sector Protect	$V_{CC} = 5.0$ V	11.5		12.5	V
$V_{OL}$	Output Low Voltage	$I_{OL} = 12$ mA, $V_{CC} = V_{CC}$ Min			0.45	V
$V_{OH1}$	Output High Voltage	$I_{OH} = -2.5$ mA, $V_{CC} = V_{CC}$ Min	$0.85 V_{CC}$			V
$V_{OH2}$		$I_{OH} = -100$ $\mu A$ , $V_{CC} = V_{CC}$ Min	$V_{CC} - 0.4$			V
$V_{LKO}$	Low $V_{CC}$ Lock-out Voltage		3.2		4.2	V

**Notes for DC Characteristics (both tables):**

1. The  $I_{CC}$  current listed includes is typically less than 1 mA/MHz, with  $OE\#$  at  $V_{IH}$ .
2.  $I_{CC}$  active while Embedded Program or Embedded Erase algorithm is in progress.
3. Not 100% tested.

TEST CONDITIONS

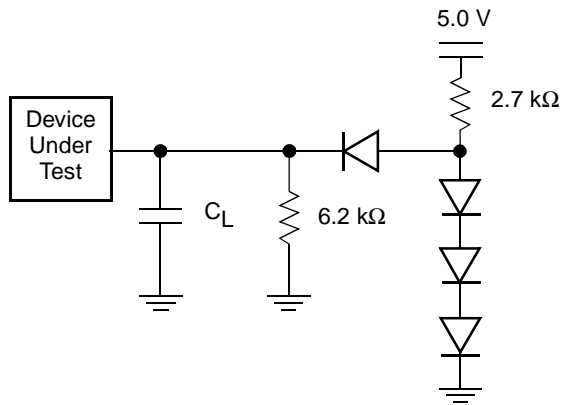

Note: Diodes are IN3064 or equivalent

21503-13

Figure 8. Test Setup

Table 7. Test Specifications

Test Condition	-75	All others	Unit
Output Load	1 TTL gate		
Output Load Capacitance, $C_L$ (including jig capacitance)	30	100	pF
Input Rise and Fall Times	5	20	ns
Input Pulse Levels	0.0–3.0	0.45–2.4	V
Input timing measurement reference levels	1.5	0.8, 2.0	V
Output timing measurement reference levels	1.5	0.8, 2.0	V

KEY TO SWITCHING WAVEFORMS

WAVEFORM	INPUTS	OUTPUTS
	Steady	
	Changing from H to L	
	Changing from L to H	
	Don't Care, Any Change Permitted	Changing, State Unknown
	Does Not Apply	Center Line is High Impedance State (High Z)

KS000010-PAL

AC CHARACTERISTICS

Read-only Operations

Parameter Symbol		Parameter Description	Test Setup		Speed Options				Unit
JEDEC	Standard				-75	-90	-120	-150	
$t_{AVAV}$	$t_{RC}$	Read Cycle Time (Note 1)		Min	70	90	120	150	ns
$t_{AVQV}$	$t_{ACC}$	Address to Output Delay	CE# = $V_{IL}$ OE# = $V_{IL}$	Max	70	90	120	150	ns
$t_{ELQV}$	$t_{CE}$	Chip Enable to Output Delay	OE# = $V_{IL}$	Max	70	90	120	150	ns
$t_{GLQV}$	$t_{OE}$	Output Enable to Output Delay		Max	40	40	50	55	ns
	$t_{OEh}$	Output Enable Hold Time (Note 1)	Read	Min	0	0	0	0	ns
			Toggle and Data# Polling	Min	10	10	10	10	ns
$t_{EHQZ}$	$t_{DF}$	Chip Enable to Output High Z		Max	20	20	30	35	ns
$t_{GHQZ}$	$t_{DF}$	Output Enable to Output High Z		Max	20	20	30	35	ns
$t_{AXQX}$	$t_{OH}$	Output Hold Time From Addresses CE# or OE# Whichever Occurs First		Min	0	0	0	0	ns
	$t_{Ready}$	RESET# Pin Low to Read Mode (Note 1)		Max	20	20	20	20	$\mu$ s

Notes:

1. Not 100% tested.
2. Refer to Figure 8 and Table 7 for test specifications.

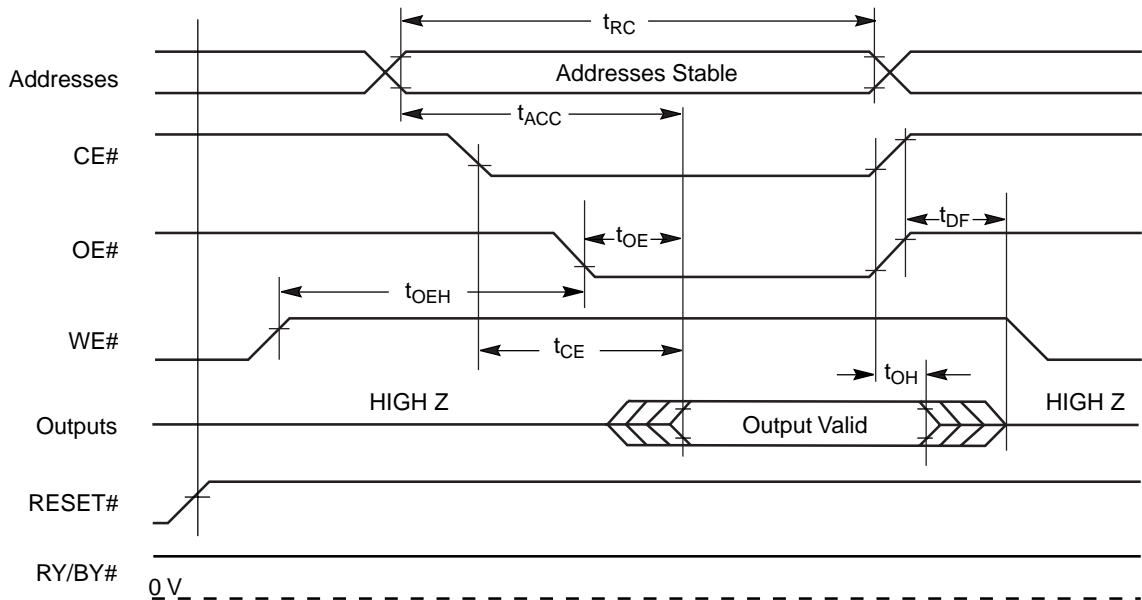

21503C-14

Figure 9. Read Operation Timings

## AC CHARACTERISTICS

### Hardware Reset (RESET#)

Parameter		Description	Test Setup		All Speed Options	Unit
JEDEC	Std					
	$t_{\text{READY}}$	RESET# Pin Low (During Embedded Algorithms) to Read or Write (See Note)		Max	20	$\mu\text{s}$
	$t_{\text{READY}}$	RESET# Pin Low (NOT During Embedded Algorithms) to Read or Write (See Note)		Max	500	ns
	$t_{\text{RP}}$	RESET# Pulse Width		Min	500	ns
	$t_{\text{RH}}$	RESET# High Time Before Read (See Note)		Min	50	ns
	$t_{\text{RPD}}$	RESET# Low to Standby Mode		Min	20	$\mu\text{s}$
	$t_{\text{RB}}$	RY/BY# Recovery Time		Min	0	ns

**Note:** Not 100% tested.

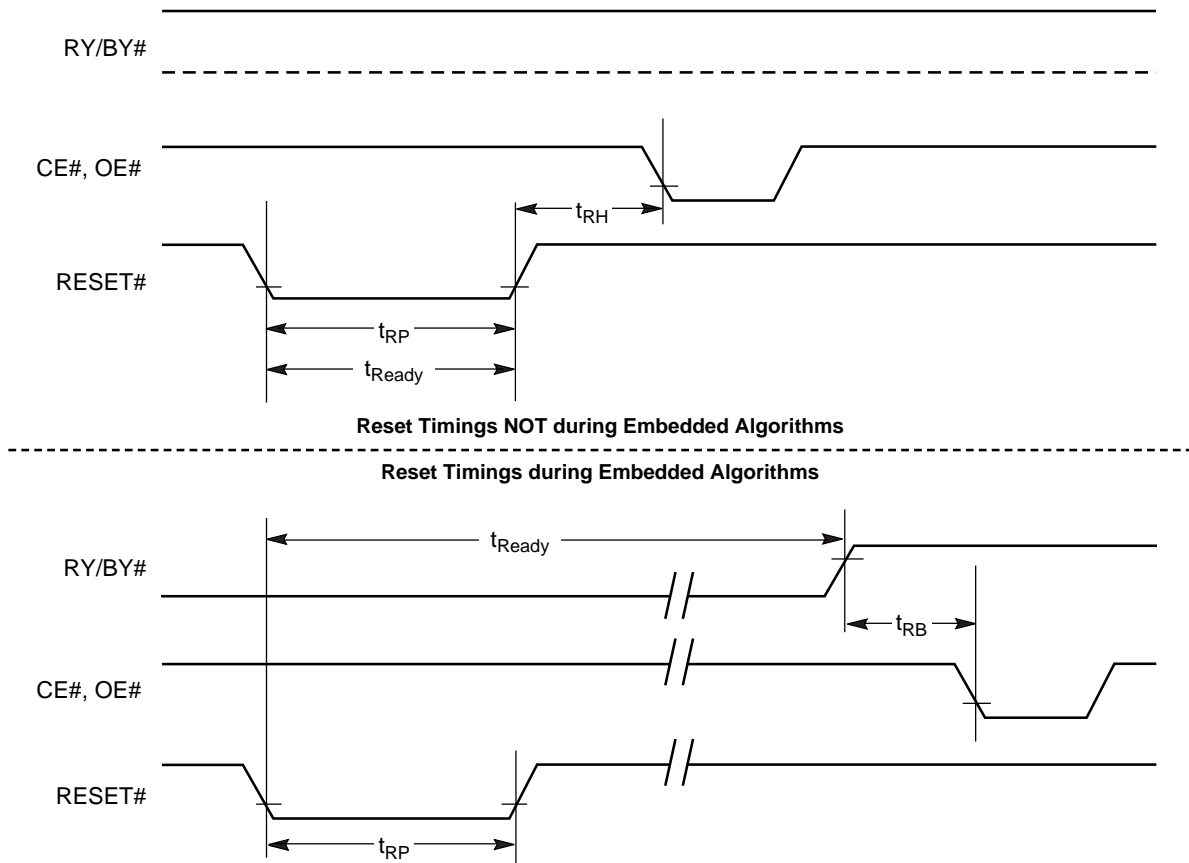

21503C-15

Figure 10. RESET# Timings

## AC CHARACTERISTICS

## Erase and Program Operations

Parameter		Parameter Description		Speed Options				Unit
JEDEC	Std.			-75	-90	-120	-150	
$t_{AVAV}$	$t_{WC}$	Write Cycle Time (Note 1)	Min	70	90	120	150	ns
$t_{AVWL}$	$t_{AS}$	Address Setup Time	Min	0				ns
$t_{WLAX}$	$t_{AH}$	Address Hold Time	Min	40	45	50	50	ns
$t_{DVWH}$	$t_{DS}$	Data Setup Time	Min	40	45	50	50	ns
$t_{WHDX}$	$t_{DH}$	Data Hold Time	Min	0				ns
	$t_{OES}$	Output Enable Setup Time	Min	0				ns
$t_{GHWL}$	$t_{GHWL}$	Read Recover Time Before Write (OE# high to WE# low)	Min	0				ns
$t_{ELWL}$	$t_{CS}$	CE# Setup Time	Min	0				ns
$t_{WHEH}$	$t_{CH}$	CE# Hold Time	Min	0				ns
$t_{WLWH}$	$t_{WP}$	Write Pulse Width	Min	40	45	50	50	ns
$t_{WHWL}$	$t_{WPH}$	Write Pulse Width High	Min	20				ns
$t_{WHWH1}$	$t_{WHWH1}$	Byte Programming Operation (Note 2)	Typ	7				$\mu$ s
$t_{WHWH2}$	$t_{WHWH2}$	Sector Erase Operation (Note 2)	Typ	1				sec
	$t_{VCS}$	$V_{CC}$ Set Up Time (Note 1)	Min	50				$\mu$ s
	$t_{BUSY}$	WE# to RY/BY# Valid	Min	40	40	50	60	ns

**Notes:**

1. Not 100% tested.
2. See the "Erase And Programming Performance" section for more information.

AC CHARACTERISTICS

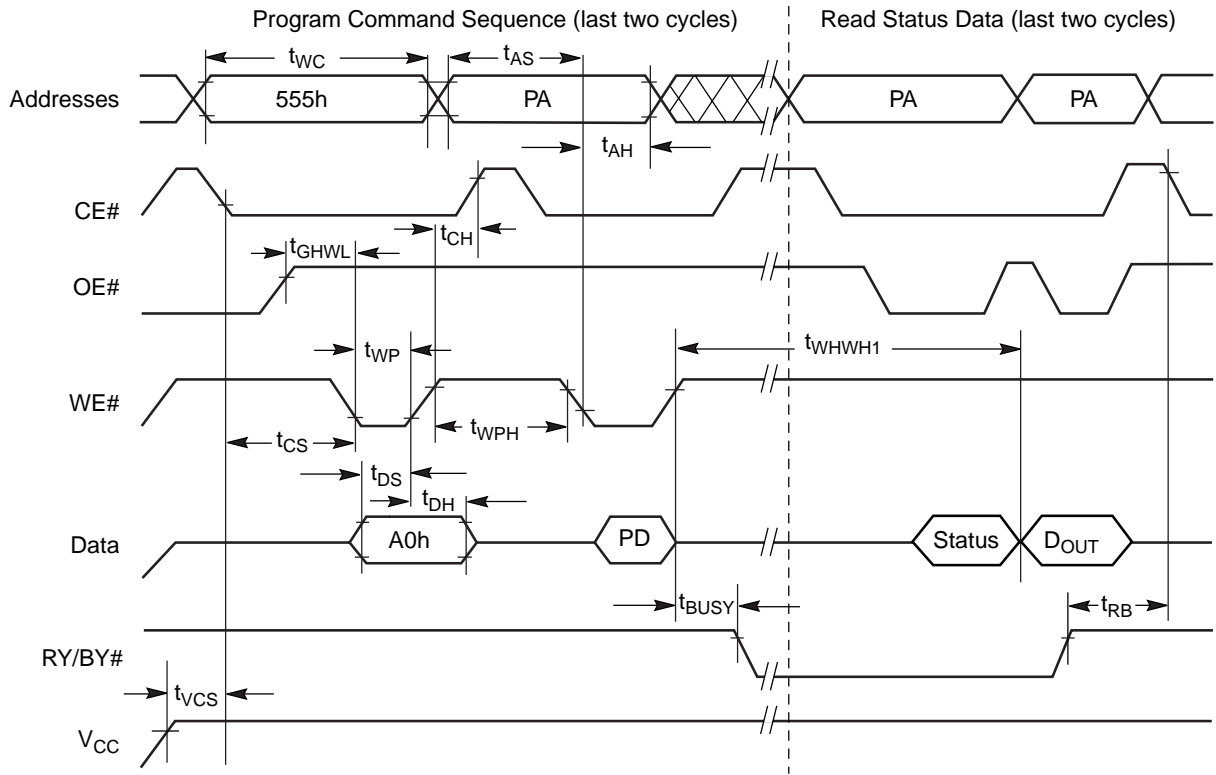

**Note:** PA = program address, PD = program data, D<sub>OUT</sub> is the true data at the program address.

21503C-16

Figure 11. Program Operation Timings

AC CHARACTERISTICS

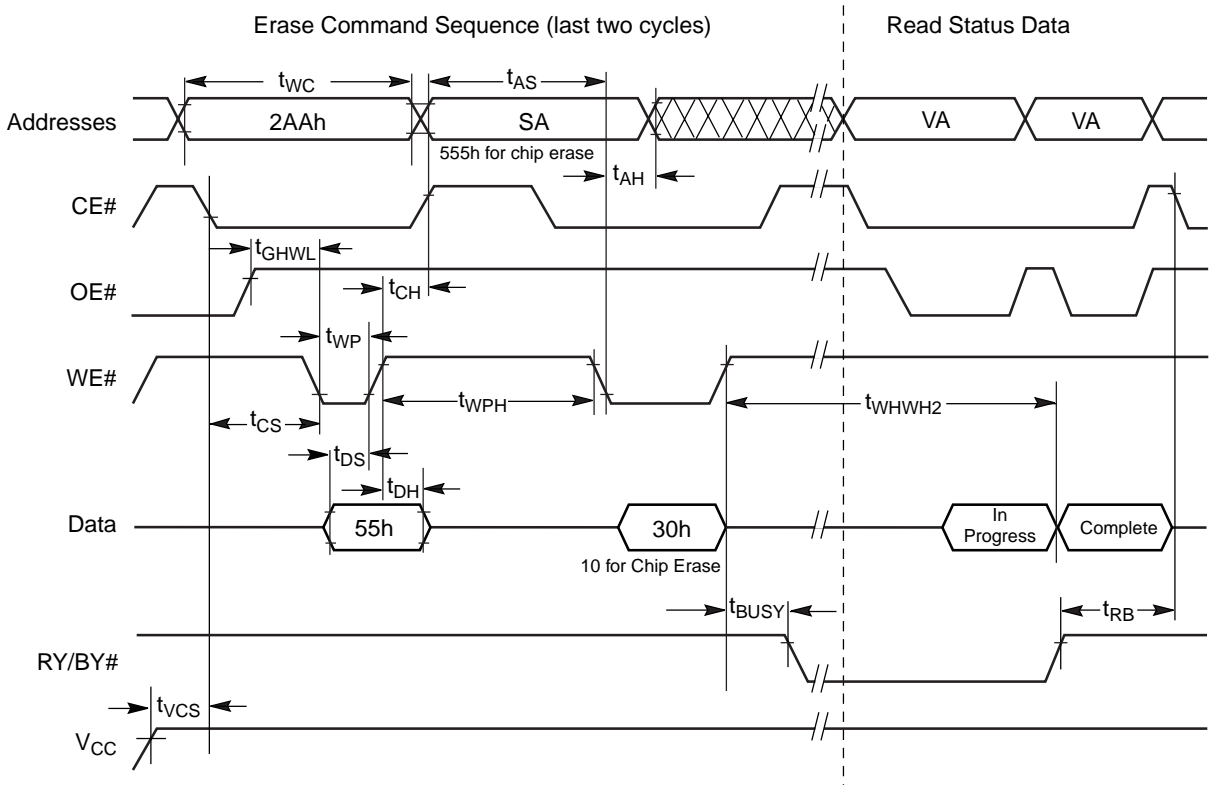

**Note:**  
 SA = Sector Address. VA = Valid Address for reading status data.

21503C-17

Figure 12. Chip/Sector Erase Operation Timings

AC CHARACTERISTICS

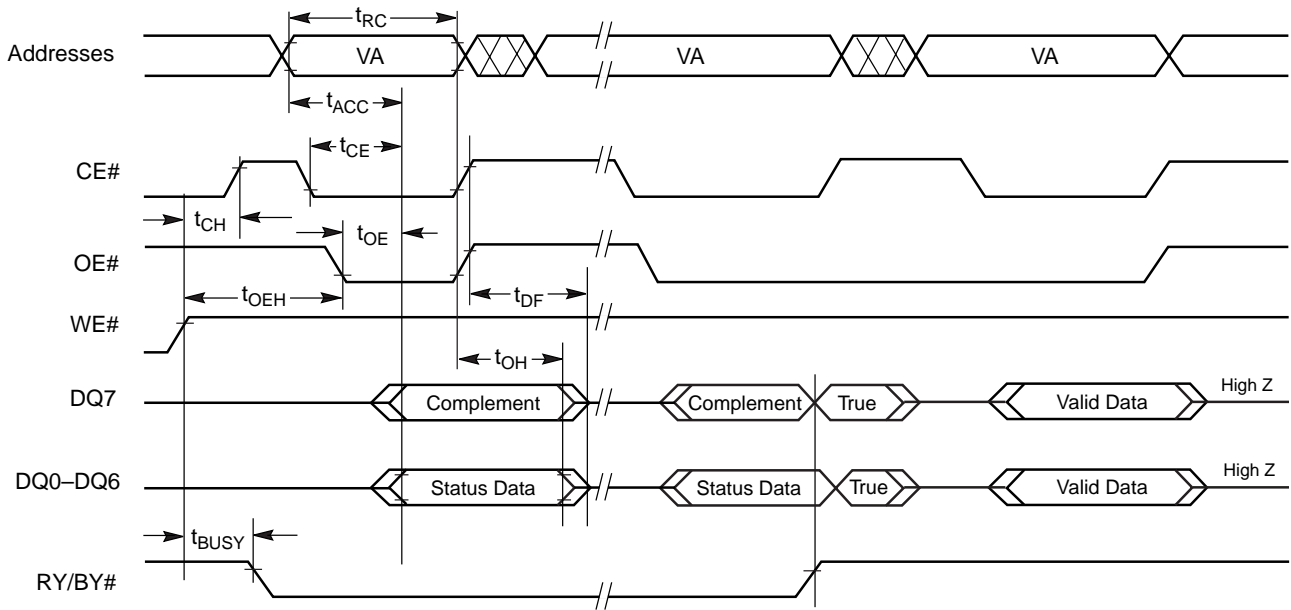

**Note:** VA = Valid address. Illustration shows first status cycle after command sequence, last status read cycle, and array data read cycle.

21503C-18

Figure 13. Data# Polling Timings (During Embedded Algorithms)

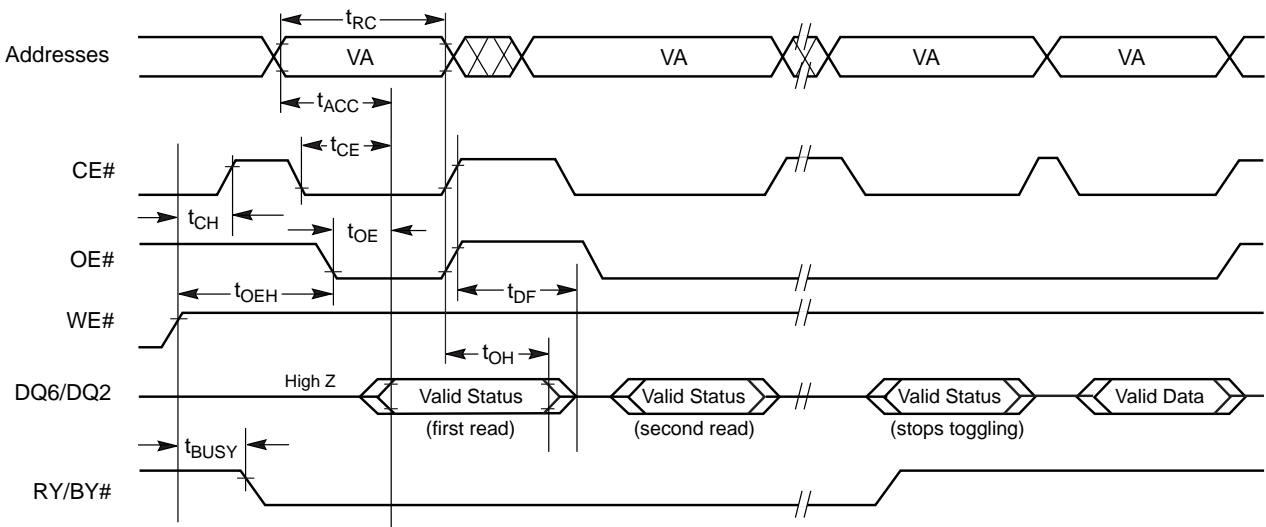

**Note:** VA = Valid address; not required for DQ6. Illustration shows first two status cycle after command sequence, last status read cycle, and array data read cycle.

21503C-19

Figure 14. Toggle Bit Timings (During Embedded Algorithms)

AC CHARACTERISTICS

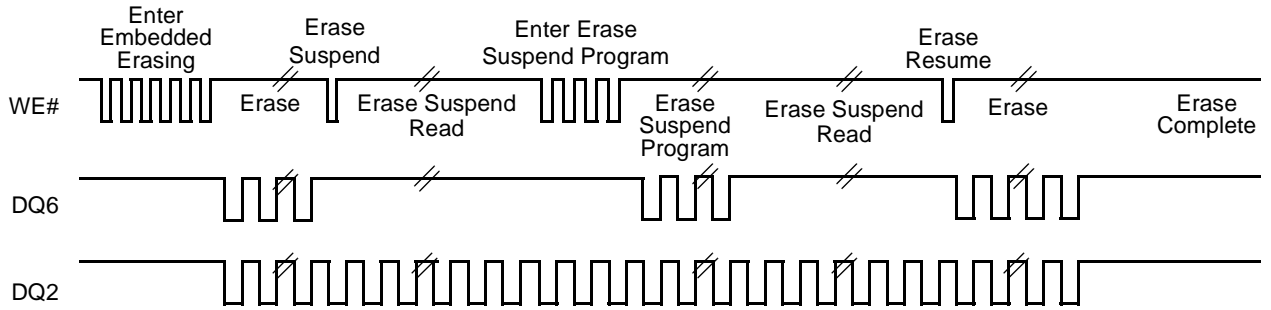

**Note:** The system may use OE# or CE# to toggle DQ2 and DQ6. DQ2 must be read at an address within the erase-suspended sector.

21503C-20

Figure 15. DQ2 vs. DQ6

Temporary Sector Unprotect

Parameter		Description		All Speed Options	Unit
JEDEC	Std.				
	$t_{VIDR}$	$V_{ID}$ Rise and Fall Time (See Note)	Min	500	ns
	$t_{RSP}$	RESET# Setup Time for Temporary Sector Unprotect	Min	4	$\mu$ s

**Note:** Not 100% tested.

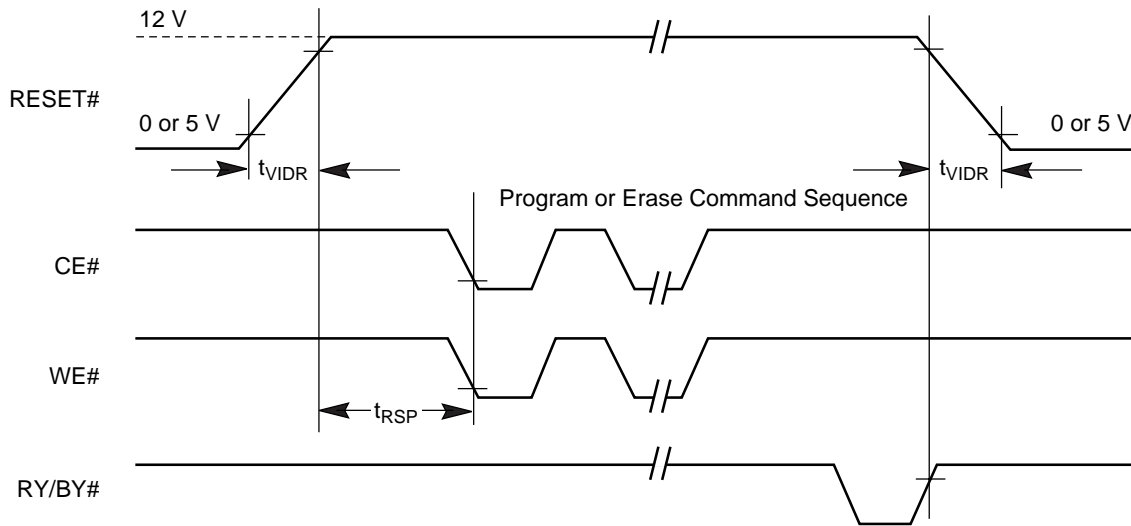

21503C-21

Figure 16. Temporary Sector Group Unprotect Timing Diagram

## AC CHARACTERISTICS

## Erase and Program Operations

## Alternate CE# Controlled Writes

Parameter Symbol		Parameter Description		Speed Options				Unit
JEDEC	Standard			-75	-90	-120	-150	
$t_{AVAV}$	$t_{WC}$	Write Cycle Time (Note 1)	Min	70	90	120	150	ns
$t_{AVEL}$	$t_{AS}$	Address Setup Time	Min	0				ns
$t_{ELAX}$	$t_{AH}$	Address Hold Time	Min	40	45	50	50	ns
$t_{DVEH}$	$t_{DS}$	Data Setup Time	Min	40	45	50	50	ns
$t_{EHDx}$	$t_{DH}$	Data Hold Time	Min	0				ns
$t_{GHLEL}$	$t_{GHLEL}$	Read Recover Time Before Write	Min	0				ns
$t_{WLEL}$	$t_{WS}$	CE# Setup Time	Min	0				ns
$t_{EHWH}$	$t_{WH}$	CE# Hold Time	Min	0				ns
$t_{ELEH}$	$t_{CP}$	Write Pulse Width	Min	40	45	50	50	ns
$t_{EHEL}$	$t_{CPH}$	Write Pulse Width High	Min	20				ns
$t_{WHWH1}$	$t_{WHWH1}$	Byte Programming Operation (Note 2)	Typ	7				$\mu$ s
$t_{WHWH2}$	$t_{WHWH2}$	Sector Erase Operation (Note 2)	Typ	1				sec

**Notes:**

1. Not 100% tested.
2. See the "Erase And Programming Performance" section for more information.

AC CHARACTERISTICS

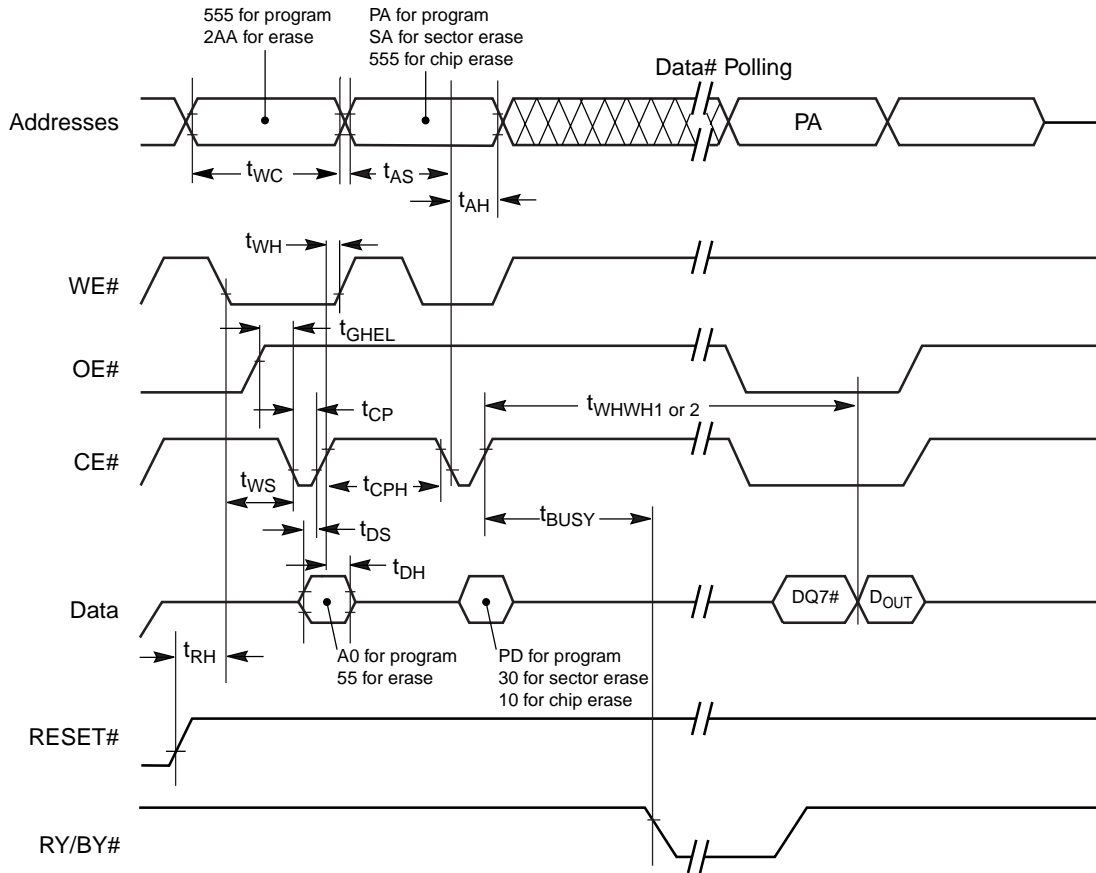

Notes:

1. PA = Program Address, PD = Program Data, SA = Sector Address, DQ7# = Complement of Data Input, D<sub>OUT</sub> = Array Data.
2. Figure indicates the last two bus cycles of the command sequence.

21503C-22

Figure 17. Alternate CE# Controlled Write Operation Timings

## ERASE AND PROGRAMMING PERFORMANCE

Parameter	Typ (Note 1)	Max (Note 2)	Unit	Comments
Sector Erase Time	1	8	sec	Excludes 00h programming prior to erasure (Note 4)
Chip Erase Time	16	128	sec	
Byte Programming Time	7	300	µs	Excludes system-level overhead (Note 5)
Chip Programming Time (Note 3)	7.2	21.6	sec	

**Notes:**

1. Typical program and erase times assume the following conditions: 25°C, 5.0 V  $V_{CC}$ , 1,000,000 cycles. Additionally, programming typicals assume checkerboard pattern.
2. Under worst case conditions of 90°C,  $V_{CC} = 4.5$  V (4.75 for -75), 1,000,000 cycles.
3. The typical chip programming time is considerably less than the maximum chip programming time listed, since most bytes program faster than the maximum byte program time listed. If the maximum byte program time given is exceeded, only then does the device set  $DQ5 = 1$ . See the section on  $DQ5$  for further information.
4. In the pre-programming step of the Embedded Erase algorithm, all bytes are programmed to 00h before erasure.
5. System-level overhead is the time required to execute the four-bus-cycle sequence for programming. See Table 5 for further information on command definitions.
6. The device has a typical erase and program cycle endurance of 1,000,000 cycles. 1,000,000 cycles are guaranteed.

## LATCHUP CHARACTERISTIC

	Min	Max
Input Voltage with respect to $V_{SS}$ on I/O pins	-1.0 V	$V_{CC} + 1.0$ V
$V_{CC}$ Current	-100 mA	+100 mA

Includes all pins except  $V_{CC}$ . Test conditions:  $V_{CC} = 5.0$  Volt, one pin at a time.

## TSOP AND SO PIN CAPACITANCE

Parameter Symbol	Parameter Description	Test Conditions	Min	Max	Unit
$C_{IN}$	Input Capacitance	$V_{IN} = 0$	6	7.5	pF
$C_{OUT}$	Output Capacitance	$V_{OUT} = 0$	8.5	12	pF
$C_{IN2}$	Control Pin Capacitance	$V_{IN} = 0$	7.5	9	pF

**Notes:**

1. Sampled, not 100% tested.
2. Test conditions  $T_A = 25^\circ\text{C}$ ,  $f = 1.0$  MHz.

## DATA RETENTION

Parameter	Test Conditions	Min	Unit
Minimum Pattern Data Retention Time	150°C	10	Years
	125°C	20	Years

PHYSICAL DIMENSIONS

SO 044—44-Pin Small Outline Package (measured in millimeters)

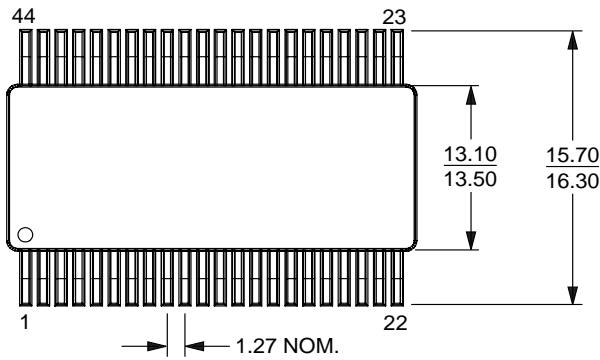

TOP VIEW

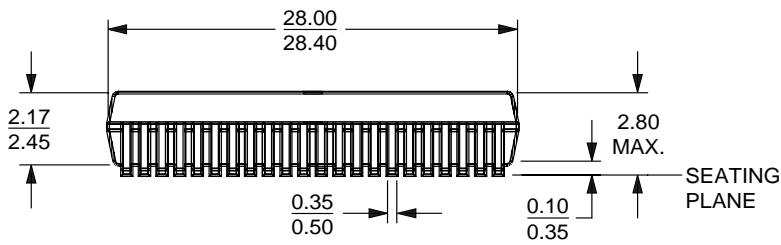

SIDE VIEW

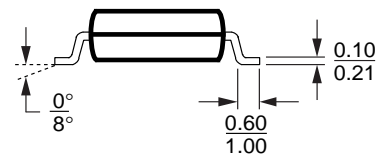

END VIEW

16-038-SO44-2  
 SO 044  
 DF83  
 8-8-96 lv

# PHYSICAL DIMENSIONS

## TS 040—40-Pin Standard Thin Small Outline Package

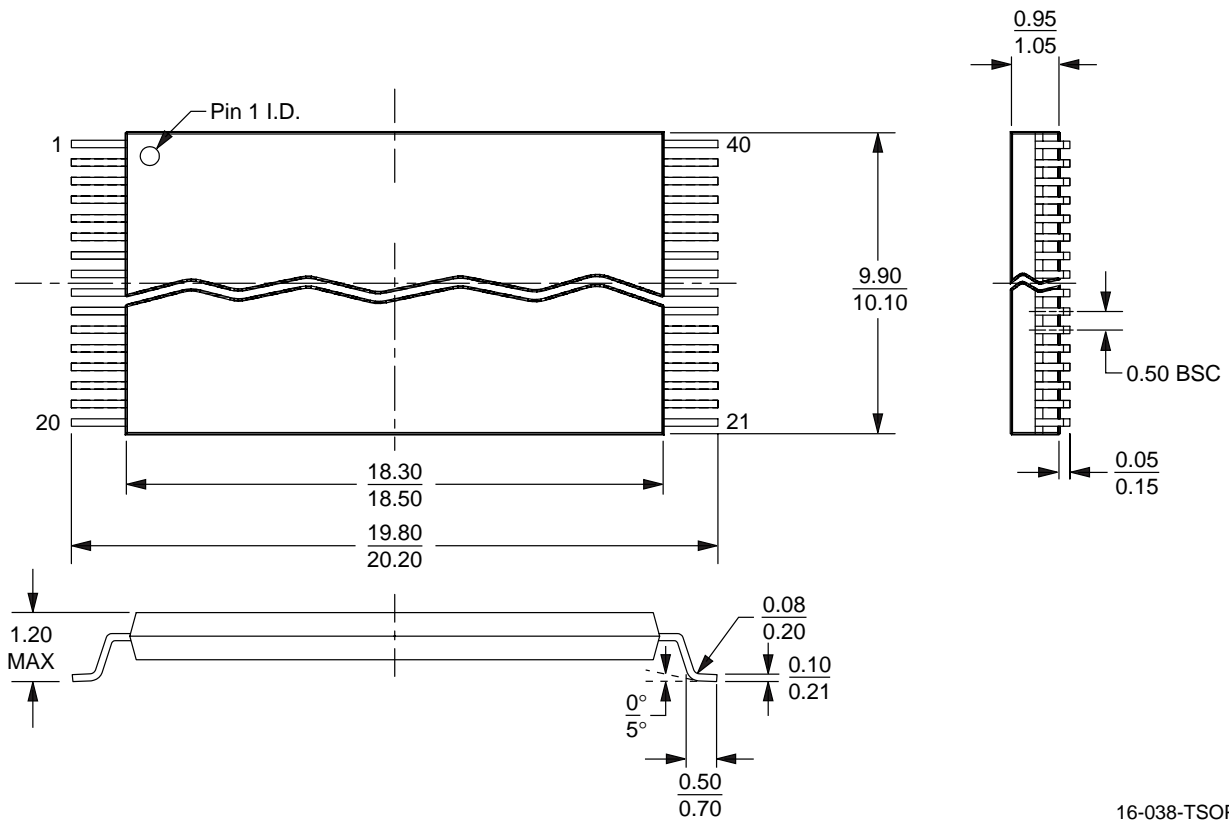

16-038-TSOP-1\_AE  
TS 040  
2-27-97 lv

PHYSICAL DIMENSIONS

TSR040—40-Pin Reverse Thin Small Outline Package

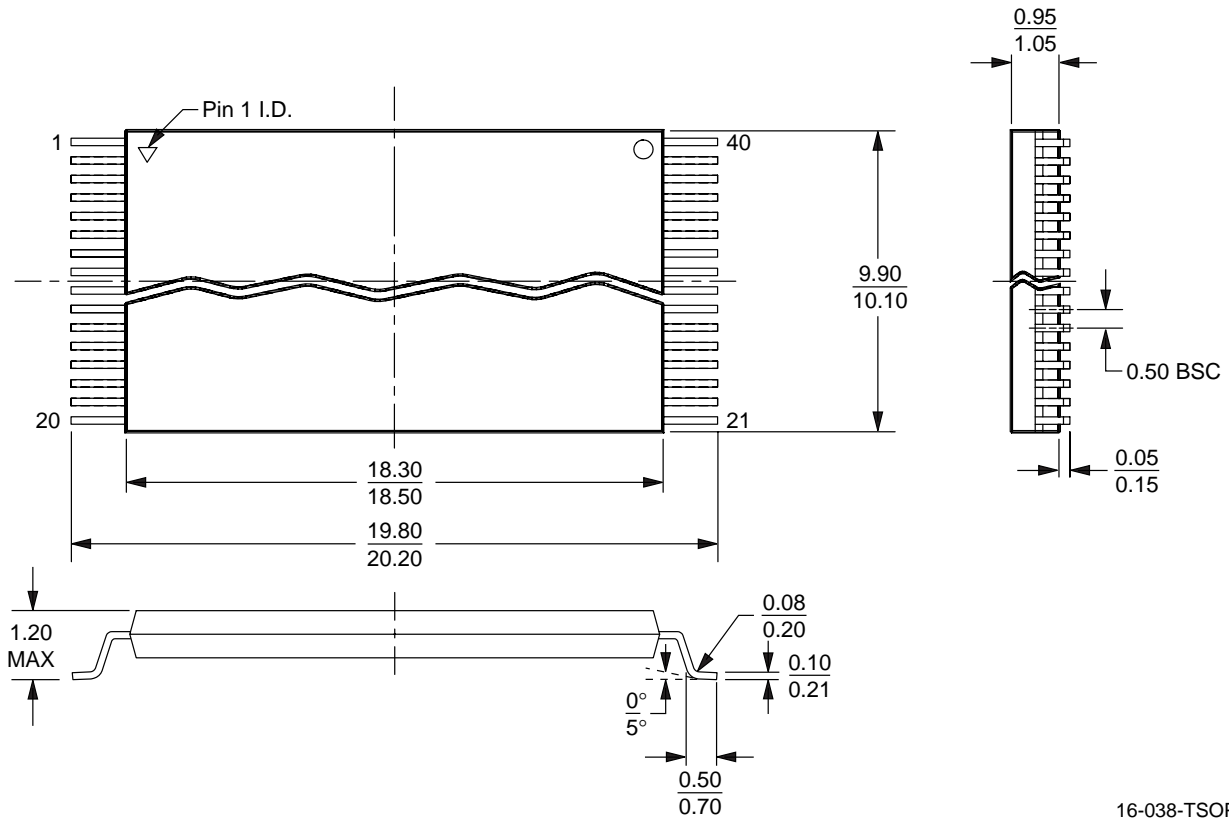

16-038-TSOP-1\_AE  
 TSR040  
 2-27-97 lv

**REVISION SUMMARY FOR AM29F080B****Revision B****Global**

Formatted for consistency with other 5.0 volt-only data sheets.

**Figure 9, Read Operation Timings**

Corrected RESET# waveform so that it is high for the duration of the read cycle.

**Figure 11, Chip/Sector Erase Operation Timings**

Corrected data unlock cycle in diagram to 55h.

**Figure 17, Alternate CE# Controlled Program Operation Timings**

Corrected command for sector erase to 30h, chip erase to 10h.

**Revision C****Standby Mode**

Removed sentence in first paragraph referring to RESET# pulse.

**Sector Group Protection/Unprotection, Temporary Sector Group Unprotect**

Changed references from “sector” to “sector group”. Corrected text to indicate sector groups are composed of two adjacent sectors.

**Revision C+1****Distinctive Characteristics**

Changed minimum 100K write/erase cycles guaranteed to 1,000,000.

**AC Characteristics**

*Erase/Program Operations; Erase and Program Operations Alternate CE# Controlled Writes:* Corrected the notes reference for  $t_{WHWH1}$  and  $t_{WHWH2}$ . These parameters are 100% tested. Corrected the note reference for  $t_{VCS}$ . This parameter is not 100% tested.

**Temporary Sector Unprotect Table**

Added note reference for  $t_{VIDR}$ . This parameter is not 100% tested.

**Command Definitions**

Corrected the shift in the table header.

**Erase and Programming Performance**

Changed minimum 100K program and erase cycles guaranteed to 1,000,000.

**Trademarks**

Copyright © 1998 Advanced Micro Devices, Inc. All rights reserved.

AMD, the AMD logo, and combinations thereof are trademarks of Advanced Micro Devices, Inc.

ExpressFlash is a trademark of Advanced Micro Devices, Inc.

Product names used in this publication are for identification purposes only and may be trademarks of their respective companies.

This datasheet has been downloaded from:

[www.DatasheetCatalog.com](http://www.DatasheetCatalog.com)

Datasheets for electronic components.



LittleDiode supplies new, hard to find or obsolete electronic components and semiconductors all over the world.

With over two million different components listed you are sure to find the part you need.

Feel free to visit us today at our online store:

[LittleDiode.com](http://LittleDiode.com)

Looking forward to providing you with the best possible service.