

---

## A 25W OFF-LINE FLYBACK SWITCHING REGULATOR

---

### INTRODUCTION

This note describes a low cost switching power supply for applications requiring multiple output voltages, e.g. personal computers, instruments, etc... The discontinuous mode flyback regulator used in this application provides good voltage tracking between outputs, which allows the use of primary side voltage sensing. This sensing technique reduces costs by eliminating the need for an isolated secondary feedback loop.

The low cost, (8 pin) UC1842 current mode control chip employed in this power supply provides performance advantages such as :

- 1) Fast transient response
- 2) Pulse by pulse current limiting
- 3) Stable operation

To simplify drive circuit requirements, a TO-220 power MOS SGSP369 is utilized for the power switch. This switch is driven directly from the output of the control chip.

### POWER SUPPLY SPECIFICATIONS

1. Input voltage : 95VAC to 130VAC (50 Hz/60 Hz)
2. Output voltage :
  - A. + 5 V,  $\pm 5\%$  : 1 A to 4 A load  
Ripple voltage : 50 mV P-P Max
  - B. + 12 V,  $\pm 3\%$  : 0.1 A to 0.3 A load  
Ripple voltage : 100 mV P-P Max
  - C. - 12 V,  $\pm 3\%$  : 0.1 A to 0.3 A load  
Ripple voltage : 100 mV P-P Max
3. Line Isolation : 3750 V
4. Switching Frequency : 40 KHz
5. Efficiency @ Full Load : 70 %

### BASIC CIRCUIT OPERATION

The 117VAC input line voltage is rectified and smoothed to provide DC operating voltage for the circuit. When power is initially applied to the circuit, capacitor C2 charges through R2. When the voltage

across C2 reaches a level of 16 V the output of IC1 is enabled, turning on power MOS Q1.

During the on time of Q1, energy is stored in the air gap of transformer (inductor) T1. At this time the polarity of the output windings is such that all output rectifiers are reverse biased and no energy is transferred. Primary current is sensed by a resistor, R10, and compared to a fixed 1 V reference inside IC1. When this level is reached, Q1 is turned off and the polarity of all transformer windings reverses, forward biasing the output rectifiers. All the energy stored is now transferred to the output capacitors. Many cycles of this store/release action are needed to charge the outputs to their respective voltages. Note that C2 must have enough energy stored initially to keep the control circuitry operating until C4 is charged to a level of approximately 13 V. The voltage across C4 is fed through a voltage divider to the error amplifier (pin 2) and compared to an internal 2.5 V reference.

Energy stored in the leakage inductance of T1 causes a voltage spike which be added to the normal reset voltage across T1 when Q1 turns off. The clamp consisting of D4, C9 and R12 limits this voltage excursion from exceeding the BVDS rating of Q1. In addition, a turn-off snubber made up of D5, C8 and R11 keeps power dissipation in Q1 low by delaying the voltage rise until drain current has decreased from its peak value. This snubber also damps out any ringing which may occur due to parasitics.

Less than 3.5% line and load regulation is achieved by loading the output of the control winding Nc, with R9. This resistor dissipates the leakage energy associated with this winding. Note that R9 must be isolated from R2 with diode D2, otherwise C2 could not charge to the 16 V necessary for initial start-up.

A small filter inductor in the 5 V secondary is added to reduce output ripple voltage to less than 50 mV. This inductor also attenuates any high frequency noise.

## APPLICATION NOTE

Figure 1 : 25W Off-line Flyback Regulator.

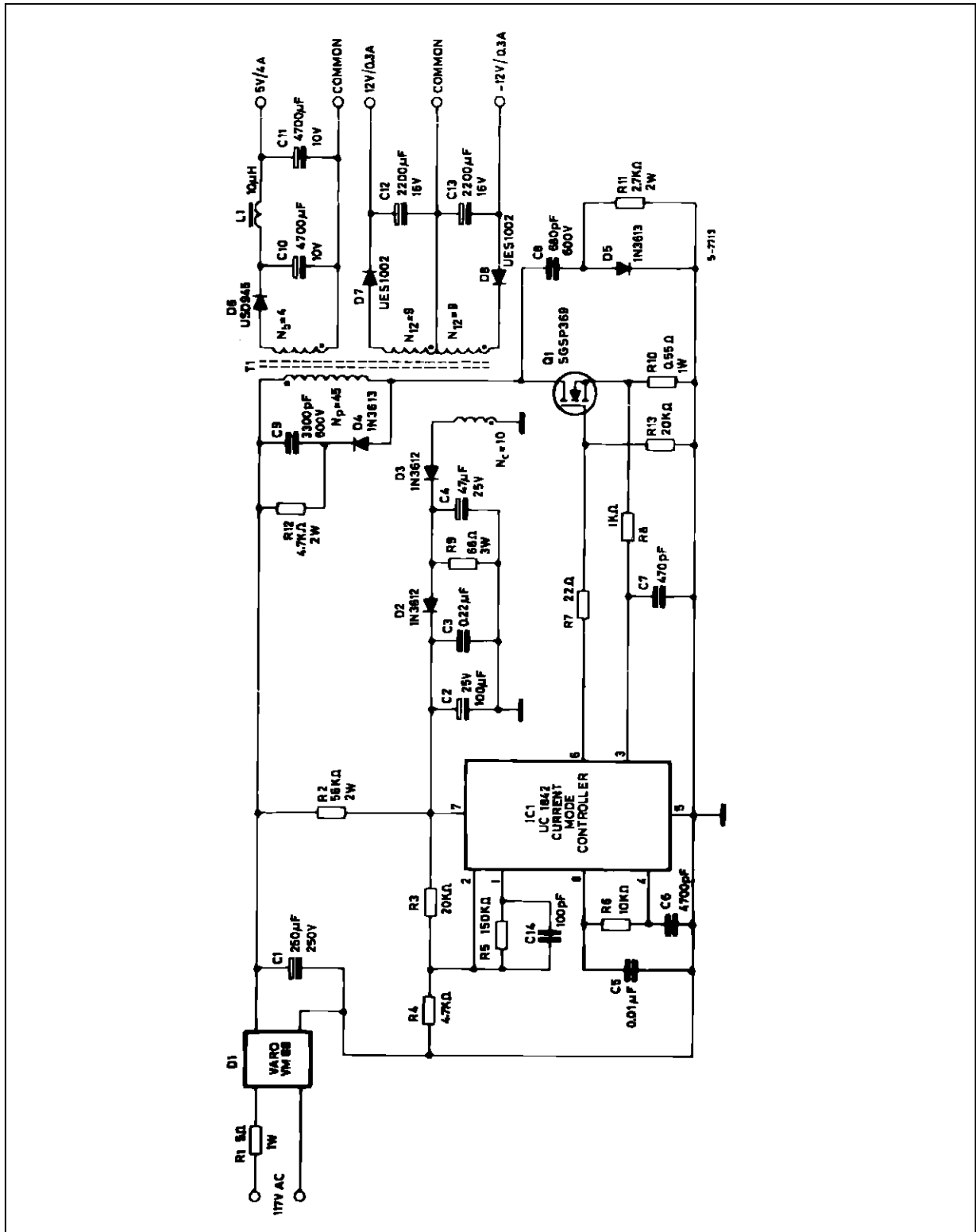

- Notes :
1. All resistors are 1/4 W unless noted.
  2. See appendix for construction details.
  3. L1 = Ferroxcube 204T50-3C8 (Toroid), N° turns : 4, Wire Gauge : 1 mm. (18 AWG).

Figure 2 : Block Diagram : UC1842 Current Mode Controller.

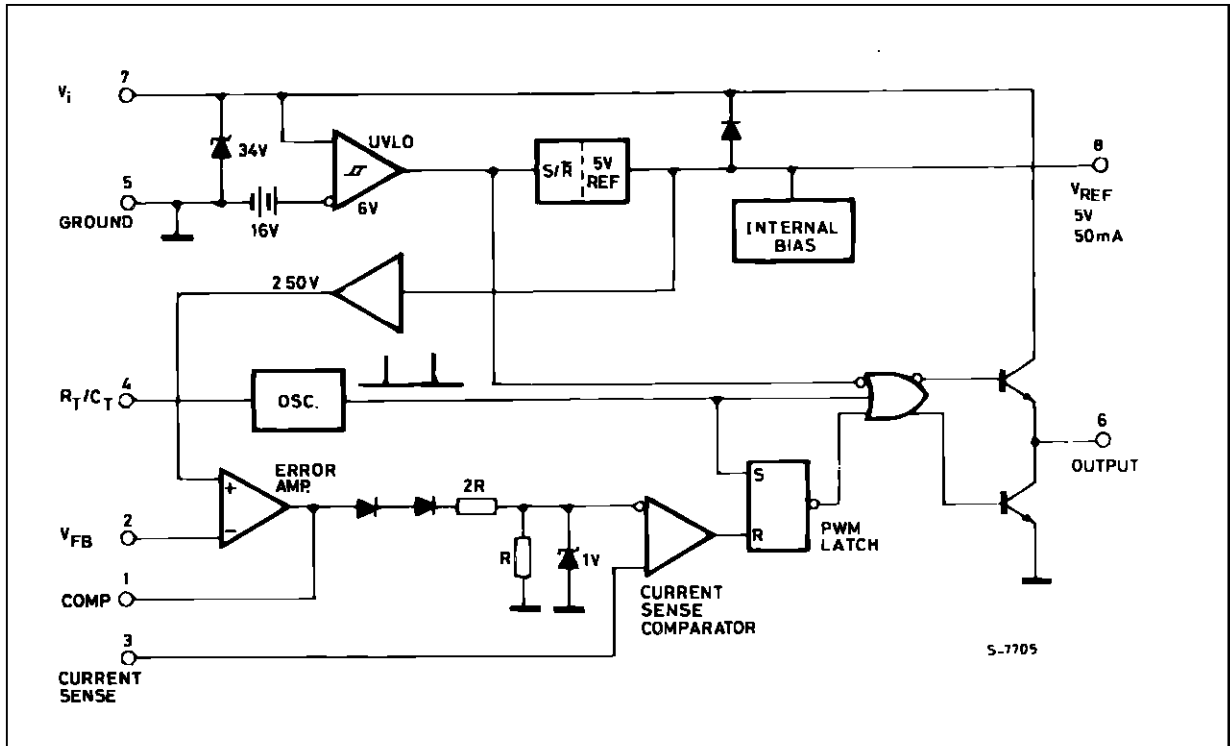

TYPICAL SWITCHING WAVEFORMS

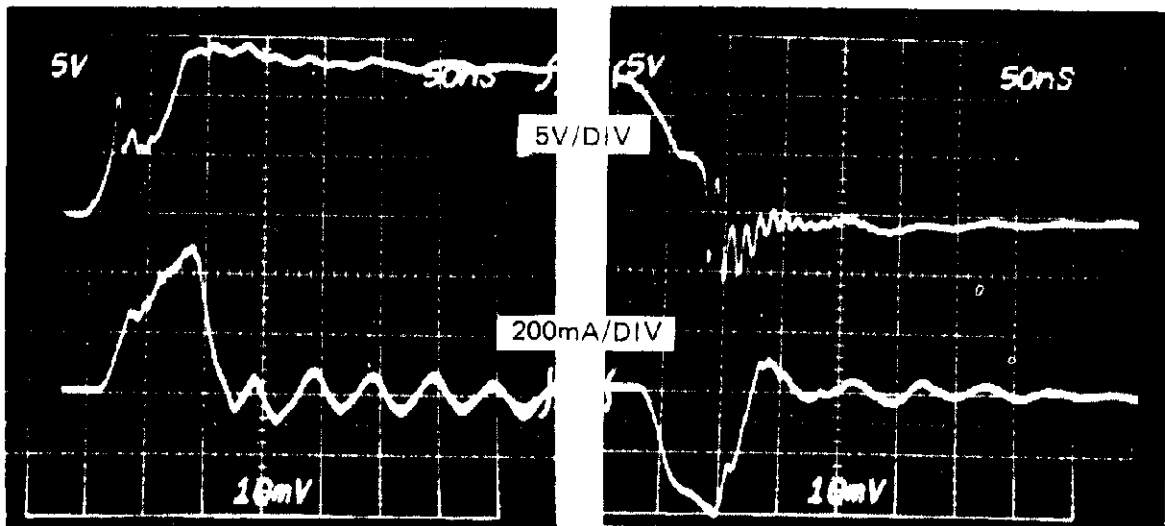

Upper trace : Q1 - Gate to source voltage  
 Lower trace : Q1 - Gate Current

## APPLICATION NOTE

### TYPICAL SWITCHING WAVEFORMS

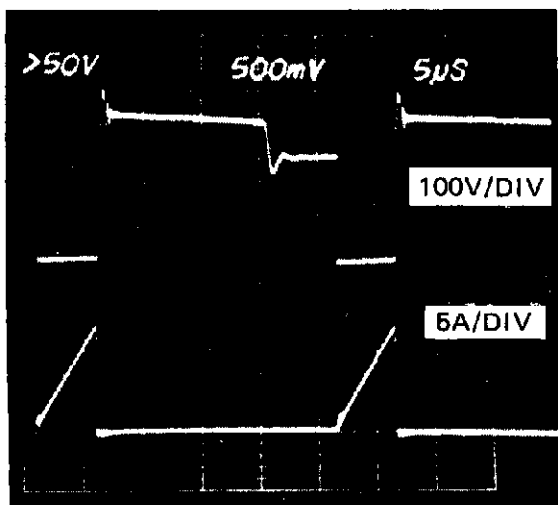

Upper trace : Q1 - Drain to source voltage  
Lower trace : Primary current -  $I_D$

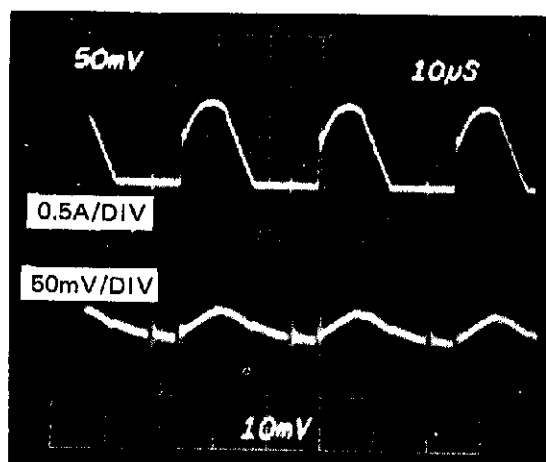

Upper trace : + 5V charging current  
Lower trace : + 5V output ripple voltage

### PERFORMANCE DATA

Conditions		5 V out	12 V out	-12 V out
<b>Low Line</b> (95 VAC) ± 12 @ 100 mA	+ 5 V @ 1.0 A 4.0 A	5.211 4.854	12.05 12.19	- 12.01 - 12.14
	+ 5 V @ 1.0 A 4.0 A	5.199 4.950	11.73 11.68	- 11.69 - 11.63
<b>Nominal Line</b> (120 VAC) ± 12 @ 100 mA	+ 5 V @ 1.0 A 4.0 A	5.220 4.875	12.07 12.23	- 12.03 - 12.18
	+ 5 V @ 1.0 A 4.0 A	5.208 4.906	11.73 11.67	- 11.68 - 11.62
<b>High Line</b> (130 VAC) ± 12 @ 100 mA	+ 5 V @ 1.0 A 4.0 A	5.207 4.855	12.06 12.21	- 12.02 - 12.15
	+ 5 V @ 1.0 A 4.0 A	5.200 4.902	11.71 11.66	- 11.67 11.61
<b>Overall Line and Load Regulation</b>		± 3.5 %	± 2.3 %	± 2.4 %

APPENDIX POWER TRANSFORMER - T1

Core : Ferroxcube EC-35/3C8  
 Gap : 0.25mm. in each outer leg

Note : For reduced EMI put gap in center leg only. Use 0.5mm.

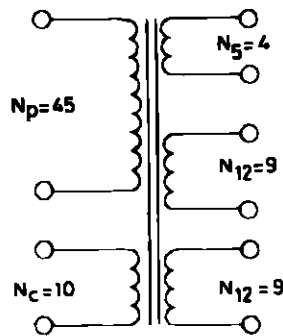

5 - 7931

TRANSFORMER CONSTRUCTION

CONTROL WINDING  
 N=10, AWG 30 (0.25mm)  
 2 IN PARALLEL

+5V OUT, N=4, AWG 26, (0.4mm)  
 6 IN PARALLEL

2 LAYERS 3M MYLAR TAPE

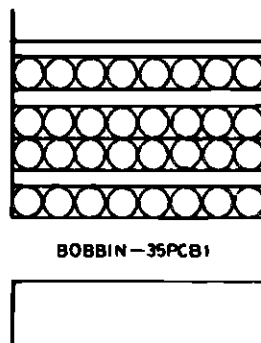

BOBBIN - 35PCB1

2 LAYERS, 3M MYLAR TAPE

±12V WINDINGS N=9, AWG30 (0.25mm)  
 2 WIRES IN PARALLEL,  
 BIFILAR WOUND

PRIMARY N=45, AWG 26 (0.4mm)

5 - 7932

## APPLICATION NOTE

---

Information furnished is believed to be accurate and reliable. However, SGS-THOMSON Microelectronics assumes no responsibility for the consequences of use of such information nor for any infringement of patents or other rights of third parties which may result from its use. No license is granted by implication or otherwise under any patent or patent rights of SGS-THOMSON Microelectronics. Specification mentioned in this publication are subject to change without notice. This publication supersedes and replaces all information previously supplied. SGS-THOMSON Microelectronics products are not authorized for use as critical components in life support devices or systems without express written approval of SGS-THOMSON Microelectronics.

© 1995 SGS-THOMSON Microelectronics – Printed in Italy – All Rights Reserved

SGS-THOMSON Microelectronics GROUP OF COMPANIES

Australia - Brazil - Canada - China - France - Germany - Hong Kong - Italy - Japan - Korea - Malaysia - Malta - Morocco - The Netherlands - Singapore - Spain - Sweden - Switzerland - Taiwan - Thailand - United Kingdom - U.S.A.



LittleDiode supplies new, hard to find or obsolete electronic components and semiconductors all over the world.

With over two million different components listed you are sure to find the part you need.

Feel free to visit us today at our online store:

[LittleDiode.com](http://LittleDiode.com)

Looking forward to providing you with the best possible service.