Up to 6 GHz Low Noise Silicon Bipolar Transistor

Technical Data

AT-41435

Features

- **Low Noise Figure:**
 - 1.7 dB Typical at 2.0 GHz
 - 3.0 dB Typical at 4.0 GHz
- **High Associated Gain:**
 - 14.0 dB Typical at 2.0 GHz
 - 10.0 dB Typical at 4.0 GHz
- **High Gain-Bandwidth Product:** 8.0 GHz Typical f_T
- **Cost Effective Ceramic Microstrip Package**

Description

Hewlett-Packard's AT-41435 is a general purpose NPN bipolar transistor that offers excellent high frequency performance. The AT-41435 is housed in a cost effective surface mount 100 mil micro-X package. The 4 micron emitter-to-emitter pitch enables this transistor to be used in many different functions. The 14 emitter

finger interdigitated geometry yields an intermediate sized transistor with impedances that are easy to match for low noise and moderate power applications. This device is designed for use in low noise, wideband amplifier, mixer and oscillator applications in the VHF, UHF, and microwave frequencies. An optimum noise match near 50Ω at 1 GHz, makes this device easy to use as a low noise amplifier.

The AT-41435 bipolar transistor is fabricated using Hewlett-Packard's 10 GHz f_T Self-Aligned-Transistor (SAT) process. The die is nitride passivated for surface protection. Excellent device uniformity, performance and reliability are produced by the use of ion-implantation, self-alignment techniques, and gold metalization in the fabrication of this device.

35 micro-X Package

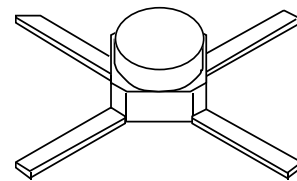

AT-41435 Absolute Maximum Ratings

| Symbol | Parameter | Units | Absolute Maximum ^[1] |
|------------------|------------------------------------|-------|---------------------------------|
| V _{EBO} | Emitter-Base Voltage | V | 1.5 |
| V _{CBO} | Collector-Base Voltage | V | 20 |
| V _{CEO} | Collector-Emitter Voltage | V | 12 |
| I _C | Collector Current | mA | 60 |
| P _T | Power Dissipation ^[2,3] | mW | 500 |
| T _j | Junction Temperature | °C | 200 |
| T _{STG} | Storage Temperature ^[4] | °C | -65 to 200 |

| |
|--|
| Thermal Resistance^{[2,5]:} $\theta_{jc} = 200^{\circ}\text{C}/\text{W}$ |
|--|

Notes:

1. Permanent damage may occur if any of these limits are exceeded.
2. T_{CASE} = 25°C.
3. Derate at 5 mW/°C for T_C > 100°C.
4. Storage above +150°C may tarnish the leads of this package making it difficult to solder into a circuit. After a device has been soldered into a circuit, it may be safely stored up to 200°C.
5. The small spot size of this technique results in a higher, though more accurate determination of θ_{jc} than do alternate methods. See MEASUREMENTS section “Thermal Resistance” for more information.

Electrical Specifications, T_A = 25°C

| Symbol | Parameters and Test Conditions | Units | Min. | Typ. | Max. |
|---------------------------------|---|---|------|------------------------------|------|
| S _{21E} ² | Insertion Power Gain; V _{CE} = 8 V, I _C = 25 mA | f = 2.0 GHz f = 4.0 GHz | dB | 11.5 6.0 | |
| P _{1dB} | Power Output @ 1 dB Gain Compression V _{CE} = 8 V, I _C = 25 mA | f = 2.0 GHz f = 4.0 GHz | dBm | 19.0 18.5 | |
| G _{1dB} | 1 dB Compressed Gain; V _{CE} = 8 V, I _C = 25 mA | f = 2.0 GHz f = 4.0 GHz | dB | 14.0 9.5 | |
| NF _O | Optimum Noise Figure; V _{CE} = 8 V, I _C = 10 mA | f = 1.0 GHz f = 2.0 GHz f = 4.0 GHz | dB | 1.3 1.7 3.0 | 2.0 |
| G _A | Gain @ NF _O ; V _{CE} = 8 V, I _C = 10 mA | f = 1.0 GHz f = 2.0 GHz f = 4.0 GHz | dB | 13.0 18.5 14.0 10.0 | |
| f _T | Gain Bandwidth Product; V _{CE} = 8 V, I _C = 25 mA | | GHz | 8.0 | |
| h _{FE} | Forward Current Transfer Ratio; V _{CE} = 8 V, I _C = 10 mA | | — | 30 | 150 |
| I _{CBO} | Collector Cutoff Current; V _{CB} = 8 V | | μA | | 0.2 |
| I _{EBO} | Emitter Cutoff Current; V _{EB} = 1 V | | μA | | 1.0 |
| C _{CB} | Collector Base Capacitance ^[1] ; V _{CB} = 8 V, f = 1 MHz | | pF | 0.2 | |

Note:

1. For this test, the emitter is grounded.

AT-41435 Typical Performance, $T_A = 25^\circ\text{C}$

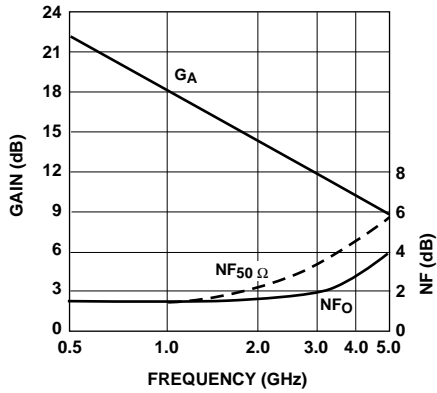

Figure 1. Noise Figure and Associated Gain vs. Frequency.
 $V_{CE} = 8\text{ V}$, $I_C = 10\text{ mA}$.

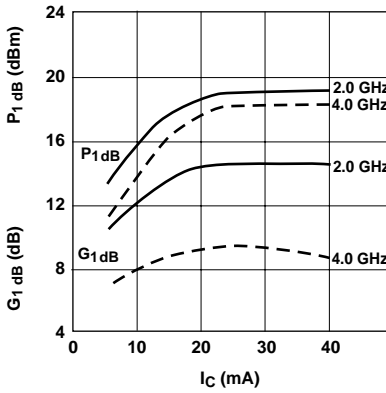

Figure 2. Output Power and 1 dB Compressed Gain vs. Collector Current and Frequency. $V_{CE} = 8\text{ V}$.

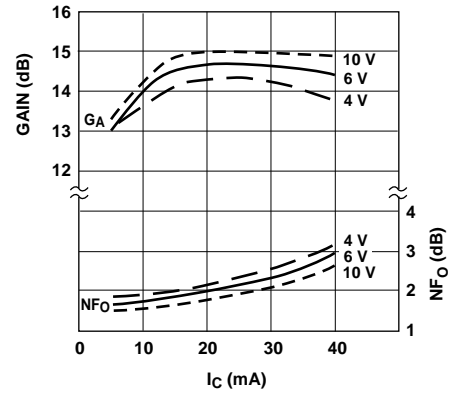

Figure 3. Optimum Noise Figure and Associated Gain vs. Collector Current and Collector Voltage. $f = 2.0\text{ GHz}$.

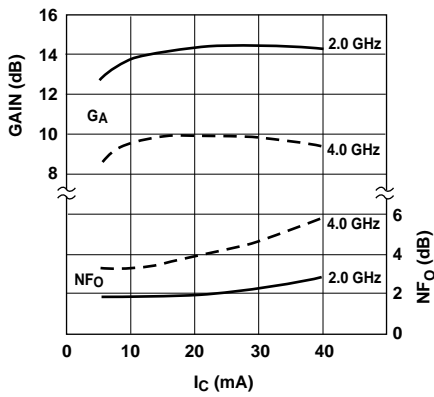

Figure 4. Optimum Noise Figure and Associated Gain vs. Collector Current and Frequency. $V_{CE} = 8\text{ V}$.

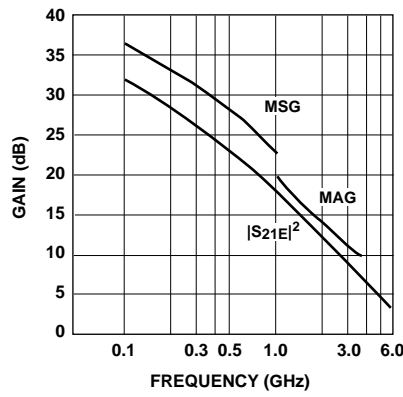

Figure 5. Insertion Power Gain, Maximum Available Gain and Maximum Stable Gain vs. Frequency.
 $V_{CE} = 8\text{ V}$, $I_C = 25\text{ mA}$.

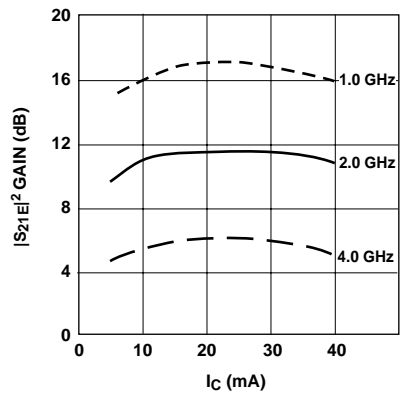

Figure 6. Insertion Power Gain vs. Collector Current and Frequency. $V_{CE} = 8\text{ V}$.

AT-41435 Typical Scattering Parameters,

Common Emitter, $Z_0 = 50 \Omega$, $T_A = 25^\circ\text{C}$, $V_{CE} = 8\text{V}$, $I_C = 10\text{mA}$

| Freq. GHz | S_{11} | | dB | S_{21} | | dB | S_{12} | | S_{22} | |
|--------------|----------|------|------|----------|------|-------|----------|------|----------|------|
| | Mag. | Ang. | | Mag. | Ang. | | Mag. | Ang. | Mag. | Ang. |
| 0.1 | .80 | -32 | 28.0 | 24.99 | 157 | -39.2 | .011 | 82 | .93 | -12 |
| 0.5 | .50 | -110 | 21.8 | 12.30 | 108 | -29.6 | .033 | 52 | .61 | -28 |
| 1.0 | .40 | -152 | 16.6 | 6.73 | 85 | -26.2 | .049 | 56 | .51 | -30 |
| 1.5 | .38 | -176 | 13.3 | 4.63 | 71 | -24.0 | .063 | 59 | .48 | -32 |
| 2.0 | .39 | 166 | 11.0 | 3.54 | 60 | -21.9 | .080 | 58 | .46 | -37 |
| 2.5 | .41 | 156 | 9.3 | 2.91 | 53 | -20.4 | .095 | 61 | .44 | -40 |
| 3.0 | .44 | 145 | 7.9 | 2.47 | 43 | -18.8 | .115 | 61 | .43 | -48 |
| 3.5 | .46 | 137 | 6.7 | 2.15 | 33 | -17.5 | .133 | 58 | .43 | -58 |
| 4.0 | .46 | 127 | 5.6 | 1.91 | 23 | -16.0 | .153 | 53 | .45 | -68 |
| 4.5 | .47 | 116 | 4.7 | 1.72 | 13 | -15.0 | .178 | 50 | .46 | -75 |
| 5.0 | .49 | 104 | 4.0 | 1.58 | 3 | -13.9 | .201 | 47 | .48 | -82 |
| 5.5 | .52 | 91 | 3.3 | 1.45 | -7 | -13.0 | .224 | 40 | .47 | -89 |
| 6.0 | .59 | 81 | 2.5 | 1.34 | -17 | -12.1 | .247 | 36 | .43 | -101 |

AT-41435 Typical Scattering Parameters,

Common Emitter, $Z_0 = 50 \Omega$, $T_A = 25^\circ\text{C}$, $V_{CE} = 8\text{V}$, $I_C = 25\text{mA}$

| Freq. GHz | S_{11} | | dB | S_{21} | | dB | S_{12} | | S_{22} | |
|--------------|----------|------|------|----------|------|-------|----------|------|----------|------|
| | Mag. | Ang. | | Mag. | Ang. | | Mag. | Ang. | Mag. | Ang. |
| 0.1 | .63 | -50 | 31.8 | 39.08 | 146 | -40.0 | .010 | 83 | .84 | -18 |
| 0.5 | .39 | -137 | 22.9 | 13.97 | 99 | -31.4 | .027 | 60 | .50 | -26 |
| 1.0 | .36 | -171 | 17.2 | 7.28 | 80 | -27.1 | .044 | 67 | .45 | -26 |
| 1.5 | .36 | 171 | 13.9 | 4.94 | 68 | -23.5 | .067 | 66 | .43 | -30 |
| 2.0 | .38 | 156 | 11.5 | 3.76 | 58 | -21.6 | .083 | 63 | .41 | -34 |
| 2.5 | .40 | 149 | 9.8 | 3.08 | 52 | -19.6 | .105 | 63 | .39 | -38 |
| 3.0 | .43 | 140 | 8.3 | 2.61 | 43 | -18.3 | .122 | 64 | .38 | -47 |
| 3.5 | .45 | 132 | 7.2 | 2.28 | 33 | -16.8 | .144 | 59 | .39 | -57 |
| 4.0 | .46 | 122 | 6.1 | 2.02 | 23 | -15.6 | .165 | 55 | .40 | -67 |
| 4.5 | .46 | 112 | 5.2 | 1.82 | 14 | -14.6 | .185 | 50 | .42 | -75 |
| 5.0 | .47 | 101 | 4.4 | 1.66 | 4 | -13.7 | .207 | 45 | .43 | -81 |
| 5.5 | .51 | 89 | 3.7 | 1.54 | -5 | -12.6 | .233 | 39 | .42 | -89 |
| 6.0 | .58 | 79 | 3.0 | 1.41 | -15 | -11.8 | .257 | 33 | .37 | -101 |

A model for this device is available in the DEVICE MODELS section.

AT-41435 Noise Parameters: $V_{CE} = 8\text{V}$, $I_C = 10\text{mA}$

| Freq. GHz | NF_0 dB | Γ_{opt} | | $R_N/50$ |
|--------------|--------------|----------------|------|----------|
| | | Mag | Ang | |
| 0.1 | 1.2 | .12 | 3 | 0.17 |
| 0.5 | 1.2 | .10 | 14 | 0.17 |
| 1.0 | 1.3 | .05 | 28 | 0.17 |
| 2.0 | 1.7 | .30 | -154 | 0.16 |
| 4.0 | 3.0 | .54 | -118 | 0.35 |

35 micro-X Package Dimensions

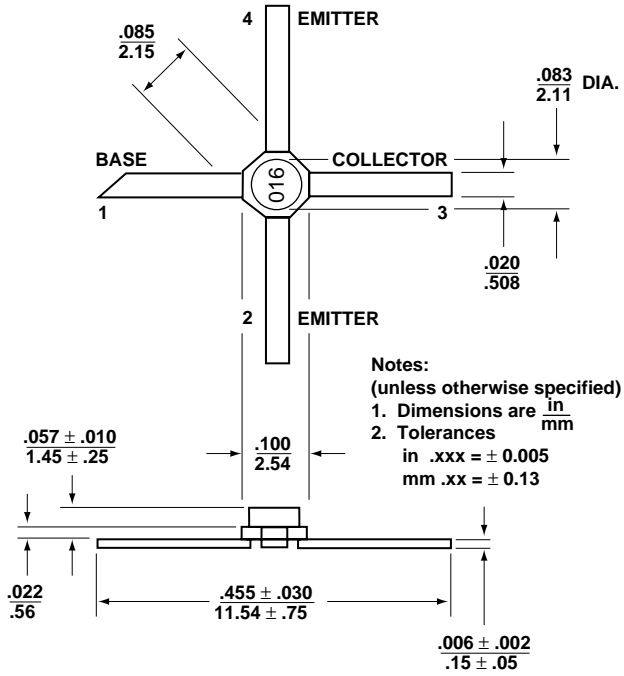



LittleDiode supplies new, hard to find or obsolete electronic components and semiconductors all over the world.

With over two million different components listed you are sure to find the part you need.

Feel free to visit us today at our online store:

LittleDiode.com

Looking forward to providing you with the best possible service.