

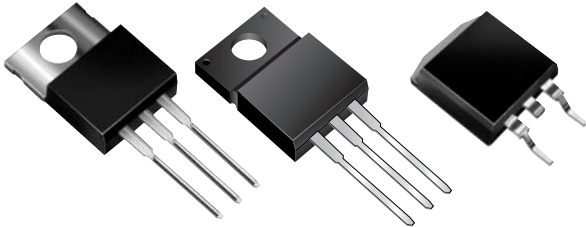

Dual Ultrafast Soft Recovery Rectifier



Reverse Voltage 300 to 400V
Forward Current 10A
Reverse Recovery Time 35ns

TO-220AB (BYT28, UG10 Series)

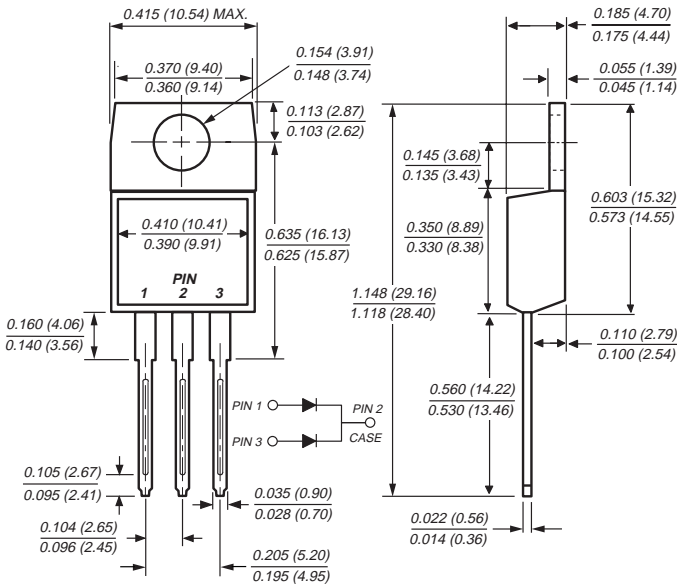

ITO-220AB (BYT28F, UGF10 Series)

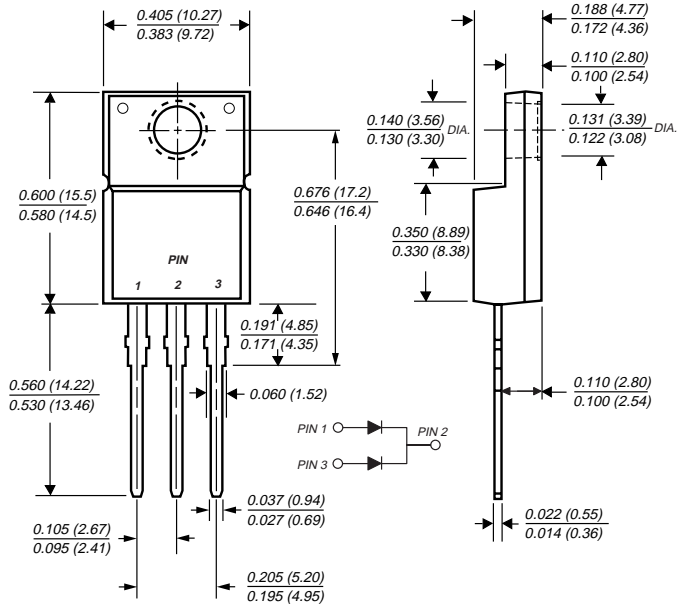

Mounting Pad Layout TO-263AB

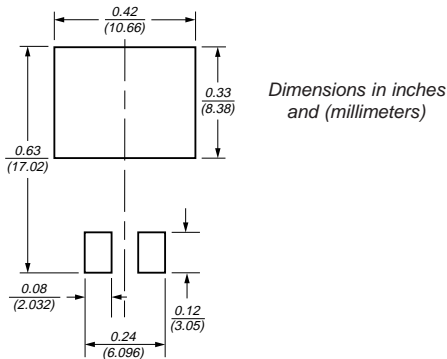

TO-263AB (BYT28B, UGB10 Series)

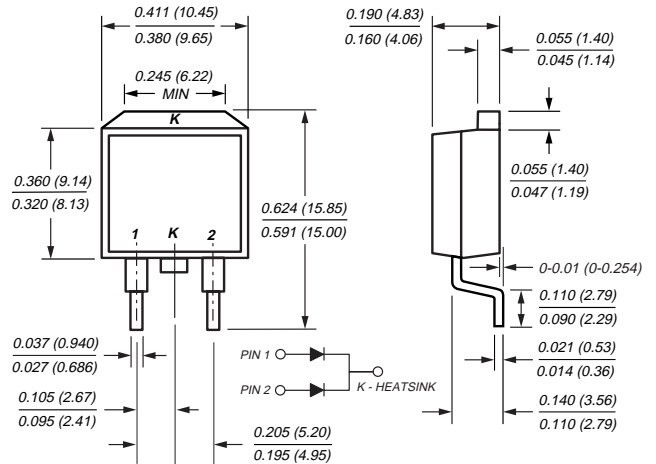

Mechanical Data

Case: JEDEC TO-220AB, ITO-220AB & TO-263AB molded plastic body

Terminals: Plated leads, solderable per MIL-STD-750, Method 2026

Polarity: As marked

Mounting Position: Any

Mounting Torque: 10 in-lbs maximum

Weight: 0.08 oz., 2.24 g

Features

- Plastic package has Underwriters Laboratories Flammability Classification 94V-0
- Ideally suited for free wheeling diode power factor correction applications
- Soft recovery characteristics
- Excellent high temperature switching
- Optimized to reduce switching losses
- High temperature soldering guaranteed: 250°C/10 seconds at terminals
- Glass passivated chip junction

Maximum Ratings (T_C = 25°C unless otherwise noted)

Parameter	Symbol	UG10FCT	UG10GCT	Unit
		BYT28-300	BYT28-400	
Maximum repetitive peak reverse voltage	V _{RRM}	300	400	V
Maximum working reverse voltage	V _{RWM}	300	400	V
Maximum RMS voltage	V _{RMS}	210	280	
Maximum DC blocking voltage	V _{DC}	300	400	V
Maximum average forward rectified current at T _C = 100°C	I _{F(AV)}	10 5		A
Peak forward surge current 8.3ms single half sine-wave superimposed on rated load (JEDEC Method) per leg	I _{FSM}	60		A
Operating junction and storage temperature range	T _J , T _{STG}	-40 to +150		°C
RMS Isolation voltage (BYT28F, UGF types) from terminals to heatsink with t = 1 second, RH ≤ 30%	V _{ISOL}	4500 ⁽¹⁾ 3500 ⁽²⁾ 1500 ⁽³⁾		V

Electrical Characteristics (T_C = 25°C unless otherwise noted)

Parameter	Symbol	Value	Unit
Maximum instantaneous forward voltage per leg ⁽⁴⁾ at I _F = 5A, T _J = 25°C at I _F = 10A, T _J = 25°C at I _F = 5A, T _J = 150°C	V _F	1.30 1.40 1.05	V
Maximum reverse current per leg at V _{RRM}	I _R	10 200	μA
Maximum reverse recovery time per leg at I _F = 0.5A, I _R = 1.0A, I _{rr} = 0.25A	t _{rr}	35	ns
Maximum reverse recovery time per leg at I _F = 1.0A, di/dt = 100A/μs, V _R = 30V, I _{rr} = 0.1 I _{RM}	t _{rr}	50	ns
Maximum reverse recovery current per leg at I _F = 5A, di/dt = 50A/μs, V _R = 30V, T _C = 100°C	I _{RM}	3.0	A
Maximum stored charge per leg I _F = 2A, di/dt = 20A/μs, V _R = 30V, I _{rr} = 0.1 I _{RM}	Q _{rr}	50	nC

Thermal Characteristics (T_C = 25°C unless otherwise noted)

Parameter	Symbol	UG10	UGF10	UGB10	Unit
		BYT28	BYT28F	BYT28B	
Typical thermal resistance junction to case	R _{θJC}	4.5	6.7	4.5	°C/W

Notes:

- (1) Clip mounting (on case), where lead does not overlap heatsink with 0.110" offset
- (2) Clip mounting (on case), where leads do overlap heatsink
- (3) Screw mounting with 4-40 screw, where washer diameter is ≤ 4.9 mm (0.19")
- (4) Pulse test: 300μs pulse width, 1% duty cycle



Ratings and Characteristic Curves ($T_A = 25^\circ\text{C}$ unless otherwise noted)

Fig 1 — Forward Current Derating Curve

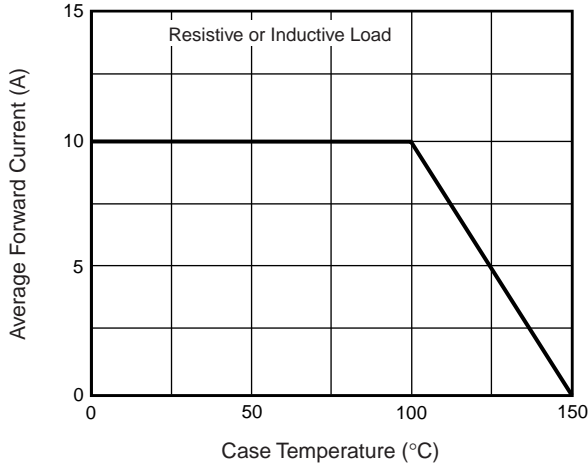

Fig 2 — Maximum Non-Repetitive Peak Forward Surge Current Per Leg

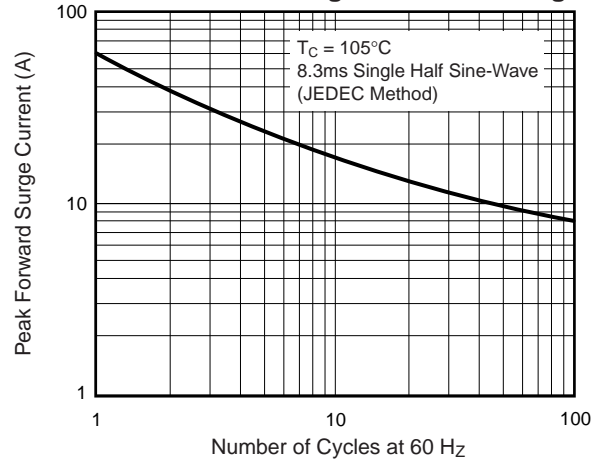

Fig 3 — Typical Instantaneous Forward Characteristics Per Leg

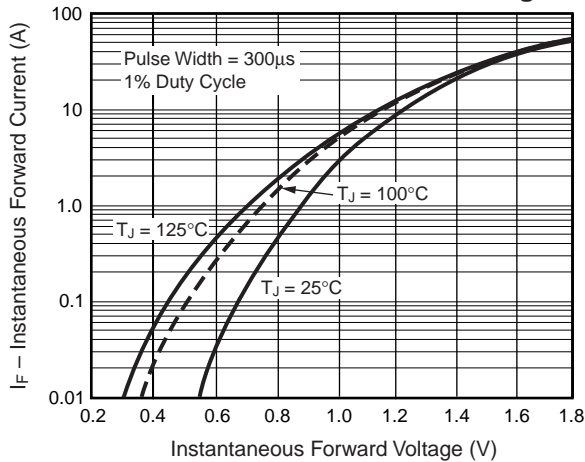

Fig 4 — Typical Reverse Characteristics Per Leg

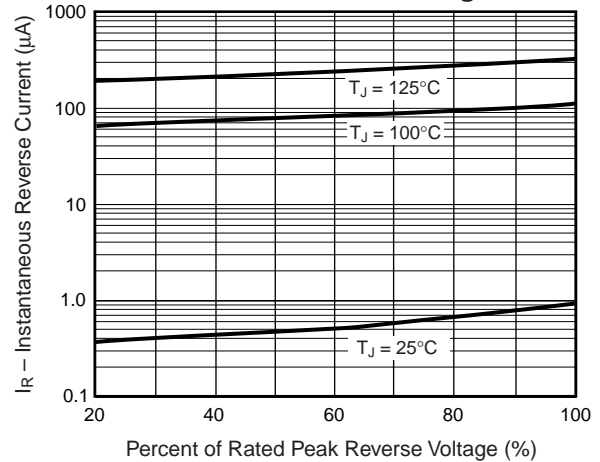

Fig 5 — Reverse Switching Characteristics Per Leg

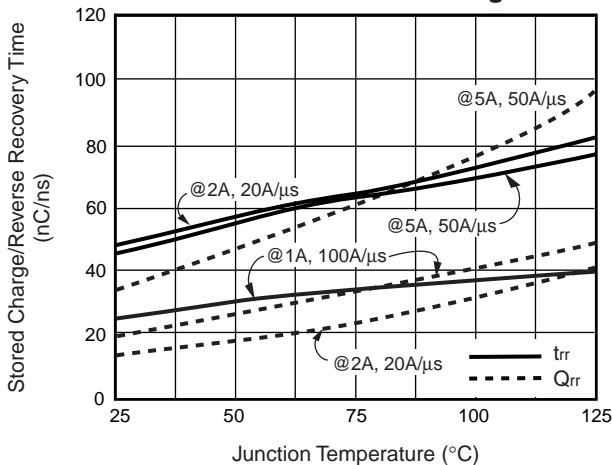
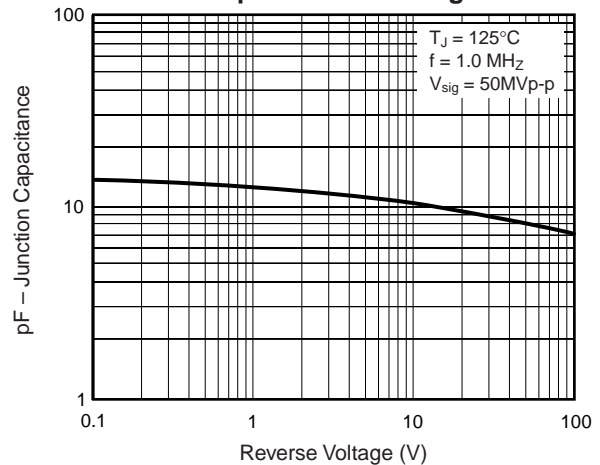

Fig 6 — Typical Junction Capacitance Per Leg





LittleDiode supplies new, hard to find or obsolete electronic components and semiconductors all over the world.

With over two million different components listed you are sure to find the part you need.

Feel free to visit us today at our online store:

LittleDiode.com

Looking forward to providing you with the best possible service.