



EVERYTHING

IN A

NEW

LIGHT.

# N-Type Silicon PIN Photodetectors

## C30807, C30808, C30809, C30810, C30822, C30831



### Description

This family of N-type silicon p-i-n photodiodes is designed for use in a wide variety of broad band low light level applications covering the spectral range from below 400 to over 1100 nm.

The different types making up this series provide a broad choice in photosensitive areas and in time response characteristics. Each of the types is antireflection coated to enhance responsivity at 900 nm.

These characteristics make the devices highly useful in HeNe and GaAs laser detection systems and in optical demodulation, data transmission, ranging, and high-speed switching applications.

### Features

- Broad Range of Photosensitive Surface Areas  
0.2 mm<sup>2</sup> to 100 mm<sup>2</sup>
- Low Operating Voltage  $V_R = 45V$
- Anti-Reflection Coated to Enhance Responsivity at 900 nm
- Hermetically-Sealed Packages
- Spectral Response Range 400 to 1100 nm

### Maximum Ratings, Absolute-Maximum Values (All Types)

DC Reverse Operating Voltage  $V_R$  .....100 max. V

Photocurrent Density,  $j_p$  at 22°C:

Average value, continuous operation ..... .5 mA/mm<sup>2</sup>

Peak value ..... .20 mA/mm<sup>2</sup>

Forward Current,  $I_F$ :

Average value, continuous operation ..... .10 max. mA

Peak value ..... .20 max. mA

Ambient Temperature:

Storage,  $T_{stg}$  ..... -60 to +100°C

Operating,  $T_A$  ..... -40 to +80°C

Soldering (for 5 seconds) ..... .200°C

**Mechanical Characteristics**

Photosensitive Surface:

Shape -

All types .....Circular

Area -

Type C30831	.....0.2 mm <sup>2</sup>
Type C30807	.....0.8 mm <sup>2</sup>
Type C30808	......5 mm <sup>2</sup>
Type C30822	......20 mm <sup>2</sup>
Type C30809	......50 mm <sup>2</sup>
Type C30810	.....100 mm <sup>2</sup>

**Optical Characteristics**

Field of View: 1

See Figure 5

Approx. Full Angle For -	Complete Illumination Photosensitive Surface	Partial Illumination Photosensitive Surface
Type C30831	70	84 deg
Type C30807	62	90 deg
Type C30808	72	120 deg
Type C30822	104	144 deg
Type C30809	74	148 deg
Type C30810	74	140 deg

Note 1. The values specified for field of view are approximate and are critically dependent on the dimensional tolerances of the package components parts.

**Electrical Characteristics at T<sub>A</sub> = 22°C At a DC Reverse Operating Voltage (V<sub>R</sub>) = 45 Volts<sup>2</sup>, unless otherwise specified**

	Type C30807			Type C30808			Type C30839			Units
	Min	Typ	Max	Min	Typ	Max	Min	Typ	Max	
<b>Breakdown Voltage, V<sub>BR</sub></b>	100	-	-	100	-	-	100	-	-	V
<b>Responsivity:</b>										
At 900 nm	0.5	0.6	-	0.5	0.6	-	0.5	0.6	-	AW
At 1060 nm	0.1	0.15	-	0.1	0.15	-	0.1	0.15	-	AW
<b>Quantum Efficiency:</b>										
At 900 nm	70	85	-	70	83	-	70	83	-	%
At 1060 nm	12	15	-	12	17	-	12	17	-	%
<b>Dark Current, i<sub>d</sub>: See Figure 2</b>										
At V <sub>R</sub> = 10 V	-	2x10 <sup>-9</sup>	1x10 <sup>-8</sup>	-	5x10 <sup>-9</sup>	2.5x10 <sup>-8</sup>	-	2.5x10 <sup>-8</sup>	1.3x10 <sup>-7</sup>	A
At V <sub>R</sub> = 45V	-	1x10 <sup>-8</sup>	5x10 <sup>-8</sup>	-	3x10 <sup>-8</sup>	1.5x10 <sup>-7</sup>	-	7x10 <sup>-8</sup>	3.5x10 <sup>-7</sup>	A
<b>Noise Current, I<sub>n</sub>: See Figure 3</b>										
f = 1000 Hz, Δf = 1.0 Hz	-	6x10 <sup>-14</sup>	4.2x10 <sup>-13</sup>	-	1x10 <sup>-13</sup>	7x10 <sup>-13</sup>	-	1.5x10 <sup>-13</sup>	1.1x10 <sup>-12</sup>	A/Hz <sup>1/2</sup>
<b>Noise Equivalent Power (NEP):</b>										
f = 1000 Hz, Δf = 1.0 Hz										
At 900 nm	-	1x10 <sup>-13</sup>	8x10 <sup>-13</sup>	-	1.5x10 <sup>-13</sup>	1.2x10 <sup>-12</sup>	-	2x10 <sup>-13</sup>	1.6x10 <sup>-12</sup>	W/Hz <sup>1/2</sup>
At 1060 nm	-	4x10 <sup>-13</sup>	3.2x10 <sup>-12</sup>	-	6.5x10 <sup>-13</sup>	5.2x10 <sup>-12</sup>	-	1x10 <sup>-12</sup>	8x10 <sup>-12</sup>	W/Hz <sup>1/2</sup>
<b>Capacitance, C<sub>d</sub>: See Figure 4</b>	-	2.5	3	-	6	10	-	35	45	pF
<b>Rise Time, t<sub>r</sub>:</b>										
R <sub>L</sub> = 50 Ω, λ = 900 nm, 10% to 90% points	-	3	5	-	5	8	-	10	15	ns
<b>Fall Time:</b>										
R <sub>L</sub> = 50 Ω, λ = 900 nm, 10% to 90% points	-	6	10	-	8	13	-	15	20	ns

Note 2. The recommended range of reverse operating voltage V<sub>R</sub> at T<sub>A</sub> = 22°C is 0 to 50 volts. However, when the devices are operated in the photovoltaic mode, i.e., at V<sub>R</sub> = 0 volts, some of the electrical characteristics will differ from those shown.

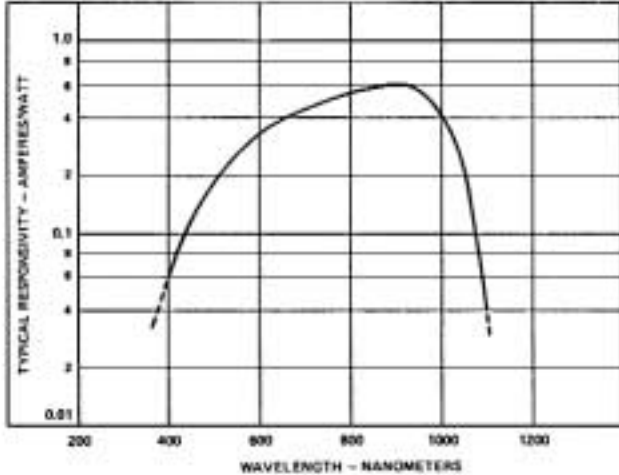

Figure 1. Typical Spectral Responsivity Characteristic

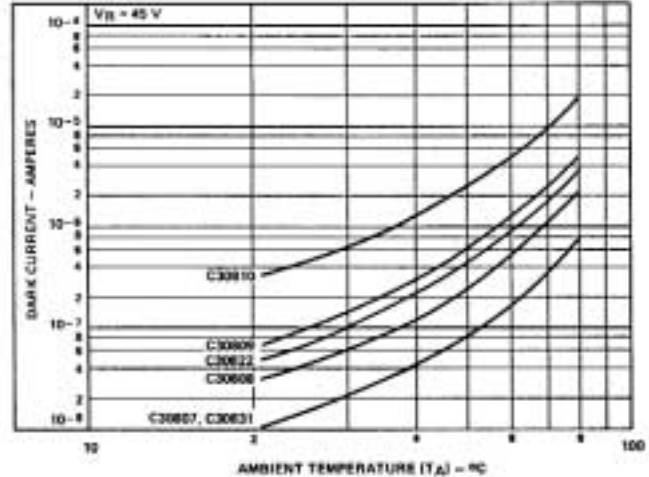

Figure 2. Typical Dark Current vs. Ambient Temperature

**Electrical Characteristics at  $T_A = 22^\circ\text{C}$  At a DC Reverse Operating Voltage ( $V_R$ ) = 45 Volts<sup>2</sup>, unless otherwise specified**

	Type C30810			Type C30822			Type C30831			Units
	Min	Typ	Max	Min	Typ	Max	Min	Typ	Max	
<b>Breakdown Voltage, <math>V_{BR}</math></b>	100	-	-	100	-	-	100	-	-	V
<b>Responsivity:</b>										
At 900 nm	0.5	0.6	-	0.5	0.6	-	0.5	0.6	-	A/W
At 1060 nm	0.1	0.15	-	0.1	0.15	-	0.1	0.15	-	A/W
<b>Quantum Efficiency:</b>										
At 900 nm	70	83	-	-	83	-	-	83	-	%
At 1060 nm	12	17	-	-	17	-	-	17	-	%
<b>Dark Current, <math>i_d</math>: See Figure 2</b>										
At $V_R = 10\text{V}$	-	$8 \times 10^{-8}$	$4 \times 10^{-7}$	-	$1 \times 10^{-8}$	$5 \times 10^{-8}$	-	$1 \times 10^{-9}$	$5 \times 10^{-9}$	A
At $V_R = 45\text{V}$	-	$3 \times 10^{-7}$	$1.5 \times 10^{-6}$	-	$5 \times 10^{-8}$	$2.5 \times 10^{-7}$	-	$1 \times 10^{-8}$	$5 \times 10^{-8}$	A
<b>Noise Current, <math>I_n</math>: See Figure 3</b>										
$f = 1000\text{ Hz}$ , $\Delta f = 1.0\text{ Hz}$	-	$3 \times 10^{-13}$	$2.1 \times 10^{-12}$	-	$1.3 \times 10^{-13}$	$9 \times 10^{-13}$	-	$6 \times 10^{-14}$	$4.2 \times 10^{-13}$	A/Hz <sup>1/2</sup>
<b>Noise Equivalent Power (NEP):</b>										
$f = 1000\text{ Hz}$ , $\Delta f = 1.0\text{ Hz}$										
At 900 nm	-	$4.5 \times 10^{-13}$	$3.6 \times 10^{-12}$	-	$2 \times 10^{-13}$	$1.5 \times 10^{-12}$	-	$1 \times 10^{-13}$	$8 \times 10^{-13}$	W/Hz <sup>1/2</sup>
At 1060 nm	-	$2 \times 10^{-12}$	$1.6 \times 10^{-11}$	-	$8 \times 10^{-13}$	$7 \times 10^{-12}$	1	$4 \times 10^{-13}$	$3.2 \times 10^{-12}$	W/Hz <sup>1/2</sup>
<b>Capacitance, <math>C_d</math>: See Figure 4</b>	-	70	90	-	17	20	-	2	2.5	pF
<b>Rise Time, <math>t_r</math>:</b>										
$RL = 50\ \Omega$ , $\lambda = 900\text{ nm}$ , 10% to 90% points	-	12	17	-	7	12	-	3	5	ns
<b>Fall Time:</b>										
$RL = 50\ \Omega$ , $\lambda = 900\text{ nm}$ , 10% to 90% points	-	20	30	-	10	15	-	6	10	ns

Note 2. The recommended range of reverse operating voltage  $V_R$  at  $T_A = 22^\circ\text{C}$  is 0 to 50 volts. However, when the devices are operated in the photovoltaic mode, i.e., at  $V_R = 0$  volts, some of the electrical characteristics will differ from those shown.

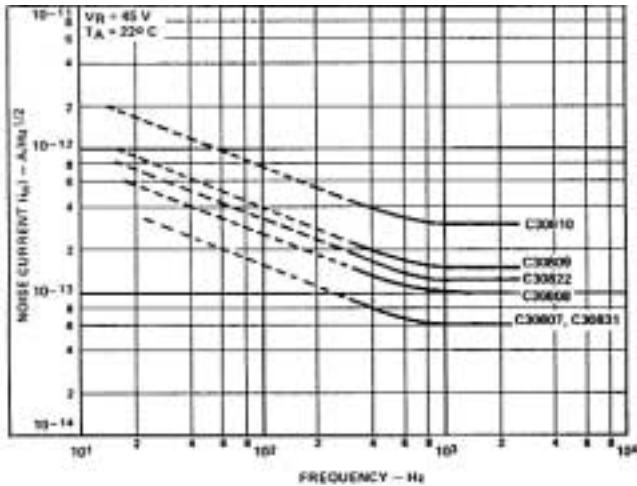

Figure 3. Typical Noise Current vs. Frequency

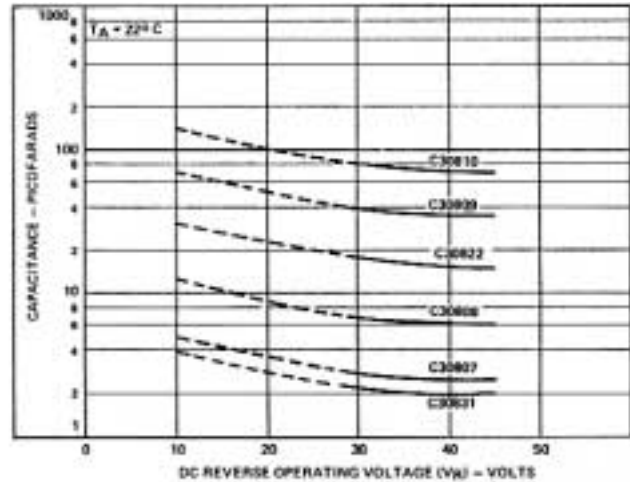

Figure 4. Typical Photodiode Capacitance vs. Operating Voltage

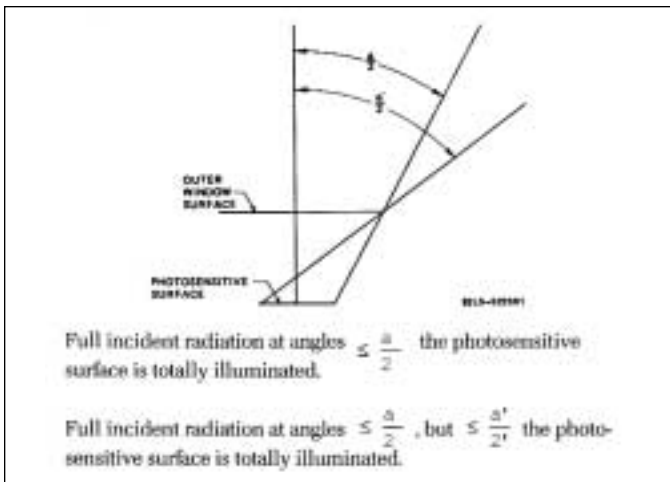

Figure 5. Definition of Half-Angle Approx. Field-of-View. (Scale is exaggerated for clarity)

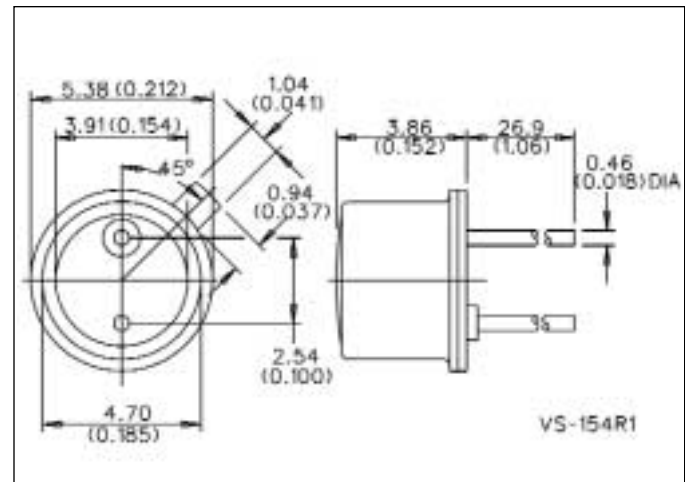

Figure 6. Dimensional Outline for C30807 and C30831

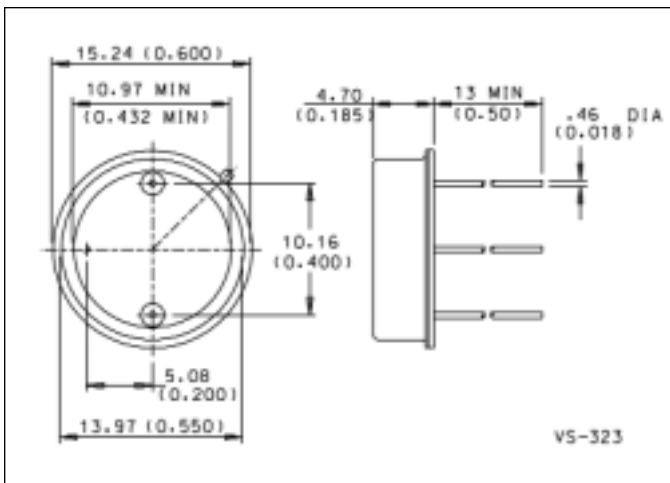

Figure 7. Dimensional Outline for C30809

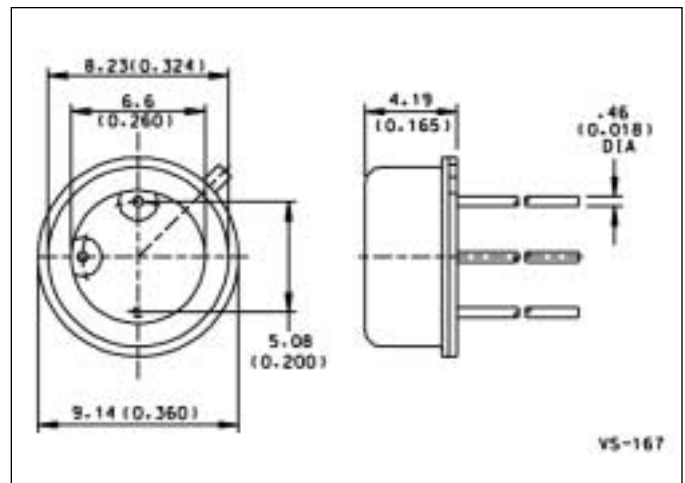

Figure 8. Dimensional Outline for C30808

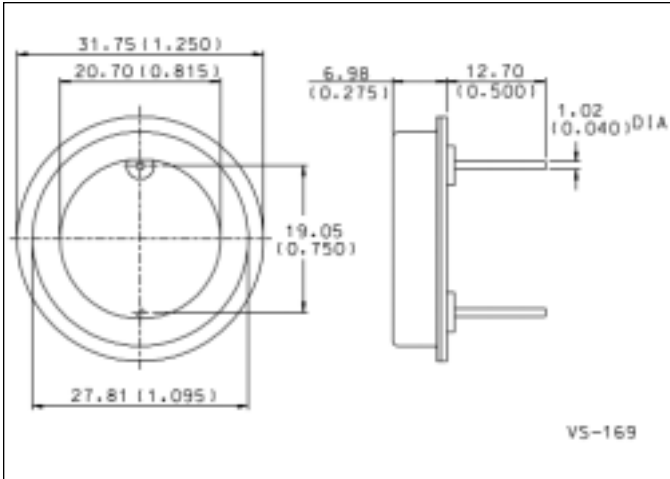

Figure 9. Dimensional Outline for C30810

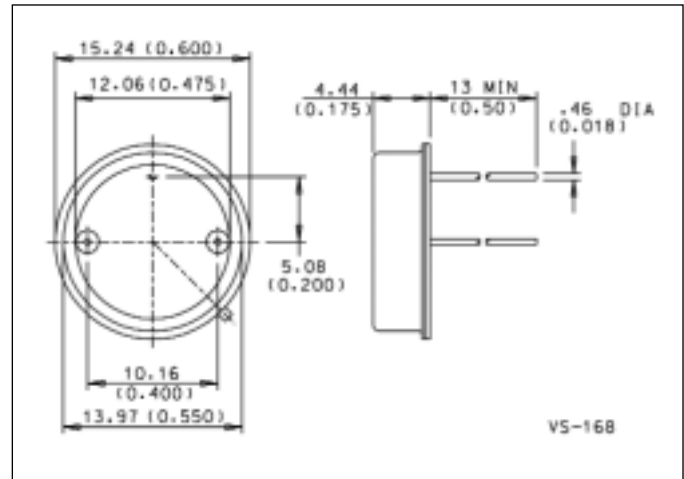

Figure 10. Dimensional Outline for C30822



LittleDiode supplies new, hard to find or obsolete electronic components and semiconductors all over the world.

With over two million different components listed you are sure to find the part you need.

Feel free to visit us today at our online store:

[LittleDiode.com](http://LittleDiode.com)

Looking forward to providing you with the best possible service.