

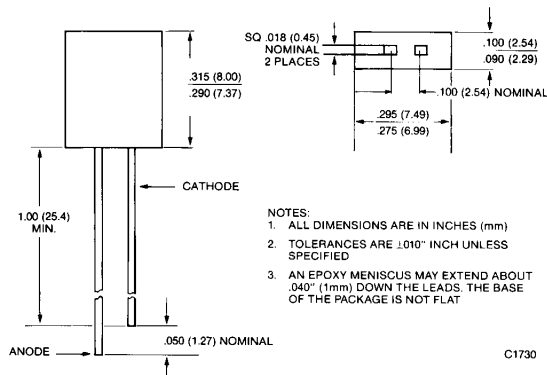

## RECTANGULAR SOLID STATE LAMPS

**HIGH EFFICIENCY RED HLMP-0300/1**  
**YELLOW HLMP-0400/1**  
**HIGH EFFICIENCY GREEN HLMP-0503/4**

### PACKAGE DIMENSIONS



### DESCRIPTION

The HLMP-0X0X Series of rectangular lamps are direct replacements for Hewlett-Packard's series with the same part numbering. The series is similar to MV5X123 except for the larger lens size. Like the MV5X123, the HLMP-0X0X is stackable. The lamps are tinted diffused and intended for direct view.

### FEATURES

- 3 High Efficiency colors
- Rectangular light area
- Inexpensive panel indicators

### PHYSICAL CHARACTERISTICS

DEVICE	SOURCE COLOR	LENS COLOR	LENS EFFECT	I <sub>v</sub> MIN. AT 20 mA
HLMP-0300	High Efficiency Red	Red Diffused	Very Wide Beam	1.0
HLMP-0301	High Efficiency Red	Red Diffused	Very Wide Beam	2.5
HLMP-0400	Yellow	Yellow Diffused	Very Wide Beam	1.5
HLMP-0401	Yellow	Yellow Diffused	Very Wide Beam	3.0
HLMP-0503	High Efficiency Green	Green Diffused	Very Wide Beam	1.5
HLMP-0504	High Efficiency Green	Green Diffused	Very Wide Beam	3.0



## RECTANGULAR SOLID STATE LAMPS

<b>ELECTRO-OPTICAL CHARACTERISTICS</b> ( $T_A=25^\circ\text{C}$ Unless Otherwise Specified)										
PARAMETER	SYMBOL	HLMP-						UNITS	TEST CONDITIONS	
		HI. EFF. RED		YELLOW		HI. EFF. GREEN				
		0300	0301	0400	0401	0503	0504			
Luminous Intensity	min.	$I_v$	1.0	2.5	1.5	3.0	1.5	2.5	mcd	$I_f=20\text{ mA}$
	typ.		2.5	5.0	2.5	5.0	3.0	5.0	mcd	$I_f=20\text{ mA}$
Forward voltage	max.	$V_f$	3.0	3.0	3.0	3.0	3.0	3.0	V	$I_f=20\text{ mA}$
	typ.		2.1	2.1	2.2	2.2	2.3	2.3	V	$I_f=20\text{ mA}$
Peak wavelength	typ.	$\lambda_p$	635	635	585	585	565	565	nm	$I_f=20\text{ mA}$
Spectral line half width	typ.	$\Delta\lambda/2$	45	45	35	35	35	35	nm	$I_f=20\text{ mA}$
Capacitance	typ.	C	45	45	45	45	20	20	pF	$V_f=0, f=1\text{ MHz}$
Reverse breakdown voltage	min.	$BV_r$	5	5	5	5	5	5	V	$I_r=100\ \mu\text{A}$
Total viewing angle between half Luminous Intensity points	typ.	$2\theta_{1/2}$	100	100	100	100	100	100	degrees	

<b>ABSOLUTE MAXIMUM RATINGS</b> ( $T_A=25^\circ\text{C}$ Unless Otherwise Specified)	
Power dissipation at 25°C ambient (HLMP-040X=85 mA)	135 mW
Derate linearly from 25°C	1.6 mW/°C
Storage and operating temperatures	-55°C to +100°C
Lead soldering time at 260°C (See Note 1)	5 sec.
Continuous forward current at 25°C (HLMP-040X=20 mA)	30 mA
Peak forward current (1 μsec pulse, 0.3% DC) (HLMP-040X=60 mA)	90 mA

**TYPICAL ELECTRO-OPTICAL CHARACTERISTIC CURVES**

( $T_A = 25^\circ\text{C}$  Unless Otherwise Specified)

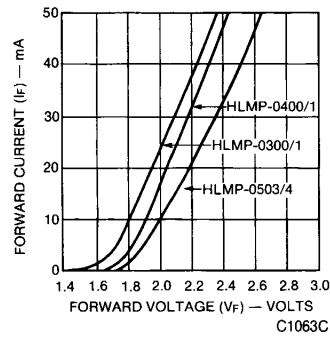

Fig. 1. Forward Current vs. Forward Voltage

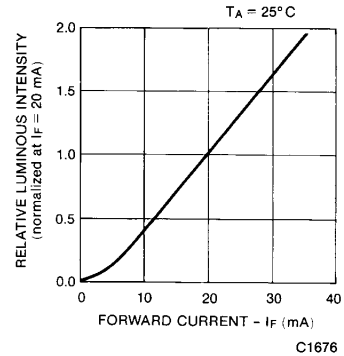

Fig. 2. Luminous Intensity vs. Forward Current

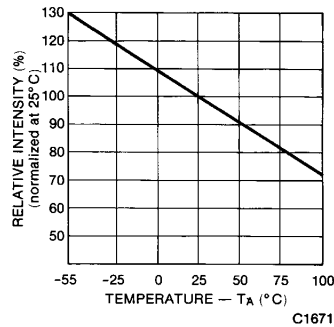

Fig. 3. Relative Luminous Intensity vs. Temperature

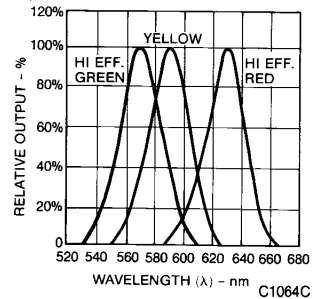

Fig. 4. Spectral Distribution

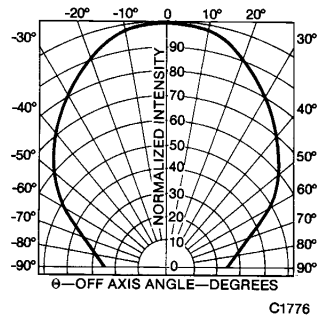

Fig. 5. Spatial Distribution

**NOTES**

1. The leads of the device immersed in molten solder, at  $260^\circ\text{C}$ , to a point 1/16 inch (1.6 mm) from the body of the device per MIL-S-750, with dwell time of 5 seconds.



LittleDiode supplies new, hard to find or obsolete electronic components and semiconductors all over the world.

With over two million different components listed you are sure to find the part you need.

Feel free to visit us today at our online store:

[LittleDiode.com](http://LittleDiode.com)

Looking forward to providing you with the best possible service.