

August 1995

Radiation Hardened Quad Differential Line Receiver

Features

- 1.2 Micron Radiation Hardened CMOS
 - Total Dose Up to 300K RAD (Si)
- Latchup Free
- EIA RS-422 Compatible Outputs
- CMOS Compatible Inputs
- Input Fail Safe Circuitry
- High Impedance Inputs when Disabled or Powered Down
- Low Power Dissipation 138mW Standby (Max)
- Single 5V Supply
- Full -55°C to +125°C Military Temperature Range

Description

The Intersil HS-26C32RH is a differential line receiver designed for digital data transmission over balanced lines and meets the requirements of EIA standard RS-422. Radiation hardened CMOS processing assures low power consumption, high speed, and reliable operation in the most severe radiation environments.

The HS-26C32RH has an input sensitivity typically of 200mV over the common mode input voltage range of $\pm 7V$. The receivers are also equipped with input fail safe circuitry, which causes the outputs to go to a logic "1" when the inputs are open. Enable and Disable functions are common to all four

Pinouts

HS1-26C32RH 16 LEAD CERAMIC SIDEBRAZE DIP
MIL-STD-1835: CDIP2-T16
TOP VIEW

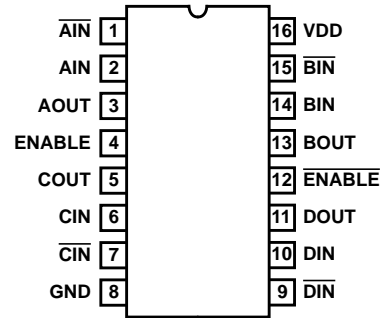

HS9-26C32RH 16 LEAD FLATPACK
MIL-STD-1835: CDFP4-F16
TOP VIEW

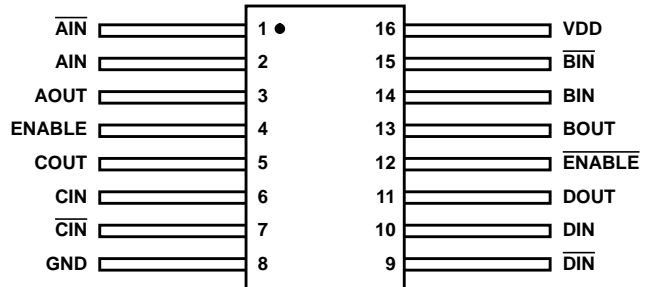

Logic Diagram

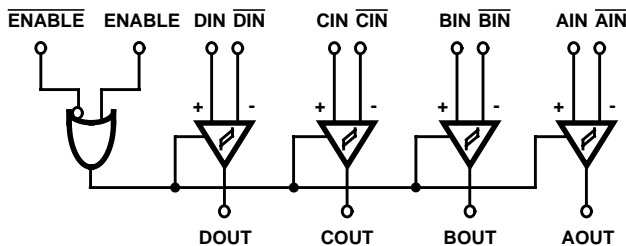

TRUTH TABLE

DEVICE POWER ON/OFF	INPUTS			OUTPUT
	ENABLE	$\overline{\text{ENABLE}}$	INPUT	OUT
ON	0	1	X	HI-Z
ON	1	X	$V_{ID} \geq V_{TH} (\text{Max})$	1
ON	1	X	$V_{ID} \leq V_{TH} (\text{Min})$	0
ON	X	0	$V_{ID} \geq V_{TH} (\text{Max})$	1
ON	X	0	$V_{ID} \leq V_{TH} (\text{Min})$	0
ON	1	X	Open	1
ON	X	0	Open	1

Ordering Information

PART NUMBER	TEMPERATURE RANGE	SCREENING LEVEL	PACKAGE
HS1-26C32RH-8	-55°C to +125°C	Intersil Class B Equivalent	16 Lead Sideboard DIP
HS1-26C32RH-Q	-55°C to +125°C	Intersil Class S Equivalent	16 Lead Sideboard DIP
HS9-26C32RH-8	-55°C to +125°C	Intersil Class B Equivalent	16 Lead Flatpack
HS9-26C32RH-Q	-55°C to +125°C	Intersil Class S Equivalent	16 Lead Flatpack
HS1-26C32RH/Sample	+25°C	Sample	16 Lead Sideboard DIP
HS1-26C32RH/Proto	-55°C to +125°C	Prototype	16 Lead Sideboard DIP
HS9-26C32RH/Sample	+25°C	Sample	16 Lead Flatpack
HS9-26C32RH/Proto	-55°C to +125°C	Prototype	16 Lead Flatpack

Specifications HS-26C32RH

Absolute Maximum Ratings

Supply Voltage	-0.5V to +7.0V
Differential Input Voltage	±12V
Common Mode Range	±12V
Enable Pins Input Voltage	-0.5V to VDD+0.5V
DC Drain Current (Any One Output)	±25mA
DC Diode Input Current Enable Pin	±1μA
Storage Temperature Range	-65°C to +150°C
Lead Temperature (Soldering 10s)	+300°C
ESD Classification	Class 1

Reliability Information

Thermal Resistance	θ_{JA}	θ_{JC}
SBDIP Package	80°C/W	20°C/W
Ceramic Flatpack Package	103°C/W	26°C/W
Maximum Package Power Dissipation at +125°C		
SBDIP Package	0.6W	
Ceramic Flatpack Package	0.5W	
Maximum Device Power Dissipation	0.3W	
Note: Maximum device Power Dissipation is defined as VDD x ICC and must withstand the added PD due to output current test; IO at +125°C		
Derating Requirements:		
SBDIP Package	No Derating Required	
Ceramic Flatpack Package	No Derating Required	

CAUTION: Stresses above those listed in "Absolute Maximum Ratings" may cause permanent damage to the device. This is a stress only rating and operation of the device at these or any other conditions above those indicated in the operational sections of this specification is not implied.

Operating Conditions

Operating Voltage Range	+4.5V to +5.5V	Input Low Voltage (VIL)	0V to 0.3VDD Max
Operating Temperature Range	-55°C to +125°C	Input High Voltage (VIH)	VDD to 0.7VDD Min
Common Mode Range	±7.0V	Input Rise and Fall Time	500ns Max

TABLE 1. DC ELECTRICAL PERFORMANCE CHARACTERISTICS

PARAMETER	SYMBOL	(NOTE 1) CONDITIONS	GROUP A SUBGROUPS	TEMPERATURE	(NOTE 2) LIMITS		UNITS
					MIN	MAX	
High Level Output Voltage	VOH	VDD = 4.5V, VDIFF = 1.0V, IO = -6mA (Notes 2, 5)	1, 2, 3	-55°C, +25°C, +125°C	4.1	-	V
Low Level Output Voltage	VOL	VDD = 4.5V, VDIFF = -1.0V, IO = 6mA (Note 5)	1, 2, 3	-55°C, +25°C, +125°C	-	0.4	V
Differential Input Voltage	VTH	VDD = VIH = 4.5V, -7.0V < VCM < 7.0V	1, 2, 3	-55°C, +25°C, +125°C	-400	+400	mV
Enabled High Level Input Voltage	VIH	VDD = 4.5V, 5.5V (Note 4)	1, 2, 3	-55°C, +25°C, +125°C	0.7 VDD	-	V
Enabled Low Level Input Voltage	VIL	VDD = 4.5V, 5.5V (Note 4)	1, 2, 3	-55°C, +25°C, +125°C	-	0.3 VDD	V
Input Current High (Differential Inputs)	IINH	VDD = 5.5, +V = 10V, -V = 0V and +V = 0V, -V = 10V	1, 2, 3	-55°C, +25°C, +125°C	-	1.8	mA
Input Current Low (Differential Inputs)	IINL	VDD = 5.5, +V = -10V, -V = 0V and +V = 0V, -V = -10V	1, 2, 3	-55°C, +25°C, +125°C	-	-2.7	mA
Input Leakage Enable Pins	IIN	VDD = 5.5V, VIN = 0V, 5.5V	1, 2, 3	-55°C, +25°C, +125°C	-	±1.0	μA
Three-State Output Leakage Current	IOZ	VDD = 5.5V, VO = VDD or GND	1, 2, 3	-55°C, +25°C, +125°C	-5.0	5.0	μA
Standby Supply Current	IDDSB	VDD = 5.5V, VDIFF = 1.0V Outputs = Open	1, 2, 3	-55°C, +25°C, +125°C	-	25	mA
Enable Clamp Voltage	VIC	At -1mA	1, 2, 3	-55°C, +25°C, +125°C	-	-1.5	V
		At 1mA			-	1.5	
Input Hysteresis	VHYST		1	-55°C, +25°C, +125°C	20	100	mV
Input Resistance	RIN	-7V ≤ VCM ≤ 7V	1	-55°C, +25°C, +125°C	4	20	kΩ

NOTES:

1. All voltages referenced to device ground.
2. Force/Measure functions may be interchanged.
3. These test condition are detailed in EIA specification RS-422.
4. This parameter tested as inputs for the VOL, VOH, IOZ tests.
5. VIL = 0.3VDD, VIH = 0.7VDD.

Specifications HS-26C32RH

TABLE 2. AC ELECTRICAL PERFORMANCE CHARACTERISTICS

PARAMETER	SYMBOL	(NOTES 1, 2) CONDITIONS	GROUP A SUBGROUPS	TEMPERATURE	LIMITS		UNITS
					MIN	MAX	
Propagation Delay Time	TPLH, TPHL	VDD = 4.5V, VDIFF = 2.5V	9, 10, 11	-55°C, +25°C, +125°C	6	40	ns
Propagation Delay Time	TPZH, TPZL	VDD = 4.5V, VDIFF = 2.5V	9, 10, 11	-55°C, +25°C, +125°C	3	18	ns
Propagation Delay Time	TPLZ, TPHZ	VDD = 4.5V, VDIFF = 2.5V	9, 10, 11	-55°C, +25°C, +125°C	6	29	ns
Propagation Delay Time TRISE/TFALL	TTHL, TTLH	VDD = 4.5V, VDIFF = 2.5V	9, 10, 11	-55°C, +25°C, +125°C	2	12	ns

NOTES:

1. All voltages referenced to device ground.
2. See Table EIA RS-422

TABLE 3. ELECTRICAL PERFORMANCE CHARACTERISTICS

PARAMETER	SYMBOL	(NOTE 1) CONDITIONS	NOTES	TEMPERATURE	LIMITS		UNITS
					MIN	MAX	
Input Capacitance	CIN	VDD = Open, f = 1MHz	1	-55°C, +25°C, +125°C	-	12	pF
Output Capacitance	COUT	VDD = Open, f = 1MHz	1	-55°C, +25°C, +125°C	-	12	pF
Fail Safe	FSAFE	+ and - Inputs are Open, VOUT = Logic "1"	1	-55°C, +25°C, +125°C	4.1	-	V

NOTE:

1. The parameters listed on Table 3 are controlled via design or process parameters. Min and Max limits are guaranteed but not directly tested. These parameters are characterized at initial design release and upon design changes which would affect these characteristics.

TABLE 4. POST IRRADIATION ELECTRICAL PERFORMANCE CHARACTERISTICS

The post irradiation electrical performance characteristics are the same as the parameters listed in Tables 1, 2 and 3.

TABLE 5. BURN-IN DELTA PARAMETERS (+25°C) AND GROUP B, SUBGROUP 5 DELTA PARAMETERS

PARAMETER	SYMBOL	DELTA LIMITS
Standby Supply Current	IDDSB	±4mA
Three-State Output Leakage Current	IOZ	±1.0µA
Low Level Output Voltage	VOL	±60mV
High Level Output Voltage	VOH	±150mV
Input Leakage Current	IIN	±150nA

TABLE 6. APPLICABLE SUBGROUPS

CONFORMANCE GROUP	MIL-STD-883 METHOD	GROUP A SUBGROUPS			
		TESTED FOR -Q	RECORDED FOR -Q	TESTED FOR -8	RECORDED FOR -8
Initial Test	100% 5004	1, 7, 9	1 (Note 2)	1, 7, 9	
Interim Test	100% 5004	1, 7, 9, Δ	1, Δ (Note 2)	1, 7, 9	
PDA 1 & 2	100% 5004	1, 7, Δ	-	1, 7	
Final Test	100% 5004	2, 3, 8A, 8B, 10, 11	-	2, 3, 8A, 8B, 10, 11	

Specifications HS-26C32RH

TABLE 6. APPLICABLE SUBGROUPS (Continued)

CONFORMANCE GROUP	MIL-STD-883 METHOD	GROUP A SUBGROUPS			
		TESTED FOR -Q	RECORDED FOR -Q	TESTED FOR -8	RECORDED FOR -8
Group A (Note 1)	Sample 5005	1, 2, 3, 7, 8A, 8B, 9, 10, 11	-	1, 2, 3, 7, 8A, 8B, 9, 10, 11	
Subgroup B5	Sample 5005	1, 2, 3, 7, 8A, 8B, 9, 10, 11	1, 2, 3 (Note 2)	N/A	
Subgroup B6	Sample 5005	1, 7, 9	-	N/A	
Group C	Sample 5005	N/A	N/A	1, 2, 3, 7, 8A, 8B, 9, 10, 11	
Group D	Sample 5005	1, 7, 9	-	1, 7, 9	
Group E, Subgroup 2	Sample 5005	1, 7, 9	-	1, 7, 9	

NOTES:

1. Alternate Group A testing in accordance with MIL-STD-883 method 5005 may be exercised.
2. Table 5 parameters only

TABLE 7. TOTAL DOSE IRRADIATION

CONFORMANCE GROUPS	METHOD	TEST		READ AND RECORD	
		PRE-RAD	POST-RAD	PRE-RAD	POST-RAD
Group E Subgroup 2	5005	1, 7, 9	Table 4	1, 7, 9	Table 4

TABLE 8. BURN-IN TEST CONNECTIONS (VDD = 6V, ±0.5V)

TEST	OPEN	GROUND	POWER SUPPLY A VDD	POWER SUPPLY B 1/2 VDD	POWER SUPPLY C 1/2 VDD	50KHz
Static Burn-In I	3, 5, 11, 13	2, 4, 6, 8, 10, 12, 14	1, 7, 9, 15, 16	-	-	-
Static Burn-In II	3, 5, 11, 13	1, 7, 8, 9, 15	2, 4, 6, 10, 12, 14, 16	-	-	-
Dynamic Burn-In Option 1	-	8, 12	4, 16	1, 3, 5, 7, 9, 11, 13, 15 (Note 2)	-	2, 6, 10, 14
Dynamic Burn-In Option 2	-	12, 8	4, 16	1, 7, 9, 15	3, 5, 11, 13	2, 6, 10, 14

NOTES:

1. Each pin except for VDD and GND will have a series resistor. (For static BI, R = 10kΩ ±5%, for dynamic BI, R = 680Ω ±5%)
2. When connecting the - inputs and their associated outputs to the same supply, a power supply bypass capacitor of 22μF must be used.

TABLE 9. IRRADIATION TEST CONNECTIONS (T_A = +25°C, ±5°C, VDD = 5V, ±10%)

TEST	OPEN	GROUND	VDD	1/2 VDD	50kHz	25kHz
Radiation Exposure	3, 5, 11, 13	2, 4, 6, 8, 10, 12, 14	1, 7, 9, 15, 16	-	-	-

NOTES:

1. Each pin except for VDD and GND will have a series resistor. (R = 47kΩ ±5%).
2. When connecting the - inputs and their associated outputs to the same supply, a power supply bypass capacitor of 22μF must be used.

Intersil Space Level Product Flow -Q

Wafer Lot Acceptance (All Lots) Method 5007 (Includes SEM)	100% Interim Electrical Test 1 (T1)
GAMMA Radiation Verification (Each Wafer) Method 1019, 4 Samples/Wafer, 0 Rejects	100% Delta Calculation (T0-T1)
100% Die Attach (Note 1)	100% Static Burn-In 2, Method 1015, Condition A or B, 24 Hours Minimum, +125°C Minimum
100% Nondestructive Bond Pull, Method 2023	100% Interim Electrical Test 1 (T2)
Sample - Wire Bond Pull Monitor, Method 2011	100% Delta Calculation (T0-T2)
Sample - Die Shear Monitor, Method 2019 or 2027	100% PDA 1, Method 5004 (Note 2)
100% Internal Visual Inspection, Method 2010, Condition A	100% Dynamic Burn-In, Condition D, 240 Hours, +125°C or Equivalent, Method 1015
CSI and/or GSI Pre-Cap (Note 7)	100% Interim Electrical Test 2(T3)
100% Temperature Cycle, Method 1010, Condition C, 10 Cycles	100% Delta Calculation (T0-T3)
100% Constant Acceleration, Method 2001, Condition per Method 5004	100% PDA 2, Method 5004 (Note 2)
100% PIND, Method 2020, Condition A	100% Final Electrical Test (T4)
100% External Visual	100% Fine/Gross Leak, Method 1014
100% Serialization	100% Radiographic (X-Ray), Method 2012 (Note 3)
100% Initial Electrical Test (T0)	100% External Visual, Method 2009
100% Static Burn-In 1, Condition A or B, 24 Hours Min, +125°C Min, Method 1015	Sample - Group A, Method 5005 (Note 4)
	Sample - Group B, Method 5005 (Note 5)
	Sample - Group D, Method 5005 (Notes 5 and 6)
	100% Data Package Generation (Note 8)
	CSI and/or GSI Final (Note 7)

NOTES:

1. Silver glass die attach shall be permitted.
2. Failures from subgroup 1, 7 and deltas are used for calculating PDA. The maximum allowable PDA = 5% with no more than 3% of the failures from subgroup 7.
3. Radiographic (X-Ray) inspection may be performed at any point after serialization as allowed by Method 5004. Per method 5004, 1 view only is supplied on flat packages and leadless chip carriers, 2 views are supplied in all other cases.
4. Alternate Group A testing may be performed as allowed by MIL-STD-883, Method 5005.
5. Group B and D inspections are optional and will not be performed unless required by the P.O. When required, the P.O. should include separate line items for Group B Test, Group B Samples, Group D Test and Group D Samples.
6. Group D Generic Data, as defined by MIL-I-38535, is optional and will not be supplied unless required by the P.O. When required, the P.O. should include a separate line item for Group D Generic Data. Group D Generic Data. Generic data is not guaranteed to be available and is therefore not available in all cases.
7. CSI and/or GSI inspections are optional and will not be performed unless required by the P.O. When required, the P.O. should include separate line items for CSI PreCap inspection, CSI Final Inspection, GSI PreCap inspection, and/or GSI Final Inspection.
8. Data Package Contents:
 - Cover Sheet (Intersil Name and/or Logo, P.O. Number, Customer Part Number, Lot Date Code, Intersil Part Number, Lot Number, Quantity).
 - Wafer Lot Acceptance Report (Method 5007). Includes reproductions of SEM photos with percent of step coverage.
 - GAMMA Radiation Report. Contains Cover page, disposition, Rad Dose, Lot Number, Test Package used, Specification Numbers, Test equipment, etc. Radiation Read and Record data on file at Intersil.
 - X-Ray report and film. Includes penetrometer measurements.
 - Screening, Electrical, and Group A attributes (Screening attributes begin after package seal).
 - Lot Serial Number Sheet (Good units serial number and lot number).
 - Variables Data (All Delta operations). Data is identified by serial number. Data header includes lot number and date of test.
 - Group B and D attributes and/or Generic data is included when required by the P.O.
 - The Certificate of Conformance is a part of the shipping invoice and is not part of the Data Book. The Certificate of Conformance is signed by an authorized Quality Representative.

Intersil Space Level Product Flow -8

GAMMA Radiation Verification (Each Wafer) Method 1019, 4 Samples/Wafer, 0 Rejects	100% Dynamic Burn-In, Condition D, 160 Hours, +125°C or Equivalent, Method 1015
100% Die Attach (Note 1)	100% Interim Electrical Test
Periodic- Wire Bond Pull Monitor, Method 2011	100% PDA, Method 5004 (Note 2)
Periodic- Die Shear Monitor, Method 2019 or 2027	100% Final Electrical Test
100% Internal Visual Inspection, Method 2010, Condition B	100% Fine/Gross Leak, Method 1014
CSI and/or GSI Pre-Cap (Note 6)	100% External Visual, Method 2009
100% Temperature Cycle, Method 1010, Condition C, 10 Cycles	Sample - Group A, Method 5005 (Note 3)
100% Constant Acceleration, Method 2001, Condition per Method 5004	Sample - Group B, Method 5005 (Note 4)
100% External Visual	Sample - Group C, Method 5005 (Notes 4 and 5)
100% Initial Electrical Test	Sample - Group D, Method 5005 (Notes 4 and 5)
	100% Data Package Generation (Note 7)
	CSI and/or GSI Final (Note 6)

NOTES:

1. Silver glass die attach shall be permitted.
2. Failures from subgroup 1, 7 are used for calculating PDA. The maximum allowable PDA = 5%.
3. Alternate Group A testing may be performed as allowed by MIL-STD-883, Method 5005.
4. Group B, C and D inspections are optional and will not be performed unless required by the P.O. When required, the P.O. should include separate line items for Group B Test, Group C Test, Group C Samples, Group D Test and Group D Samples.
5. Group C and/or Group D Generic Data, as defined by MIL-I-38535, is optional and will not be supplied unless required by the P.O. When required, the P.O. should include a separate line item for Group C Generic Data and/or Group D Generic Data. Generic data is not guaranteed to be available and is therefore not available in all cases.
6. CSI and/or GSI inspections are optional and will not be performed unless required by the P.O. When required, the P.O. should include separate line items for CSI PreCap inspection, CSI Final Inspection, GSI PreCap inspection, and/or GSI Final Inspection.
7. Data Package Contents:
 - Cover Sheet (Intersil Name and/or Logo, P.O. Number, Customer Part Number, Lot Date Code, Intersil Part Number, Lot Number, Quantity).
 - GAMMA Radiation Report. Contains Cover page, disposition, Rad Dose, Lot Number, Test Package used, Specification Numbers, Test equipment, etc. Radiation Read and Record data on file at Intersil.
 - Screening, Electrical, and Group A attributes (Screening attributes begin after package seal).
 - Group B, C and D attributes and/or Generic data is included when required by the P.O.
 - The Certificate of Conformance is a part of the shipping invoice and is not part of the Data Book. The Certificate of Conformance is signed by an authorized Quality Representative.

Propagation Delay Timing Diagram

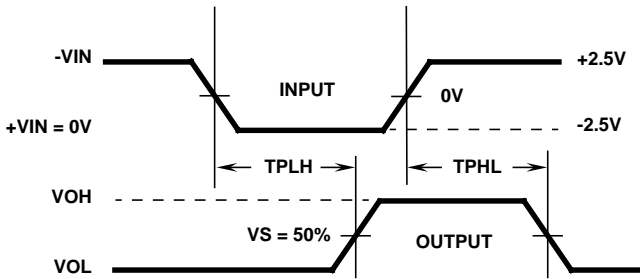

Propagation Delay Load Circuit

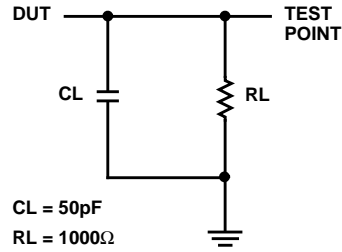

Three-State Low Timing Diagrams

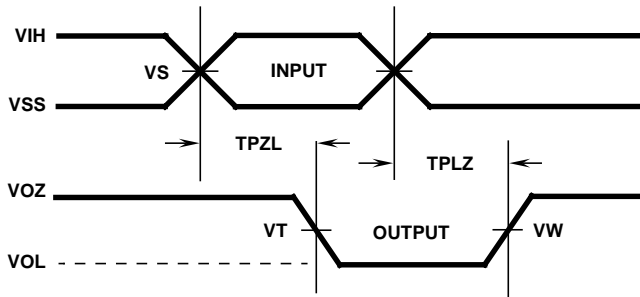

THREE-STATE LOW VOLTAGE LEVELS

PARAMETER	HS-26C32RH	UNITS
VDD	4.50	V
VIH	4.50	V
VS	2.25	V
VT	50	%
VW	VOL + 0.5	V
GND	0	V

Three-State High Timing Diagrams

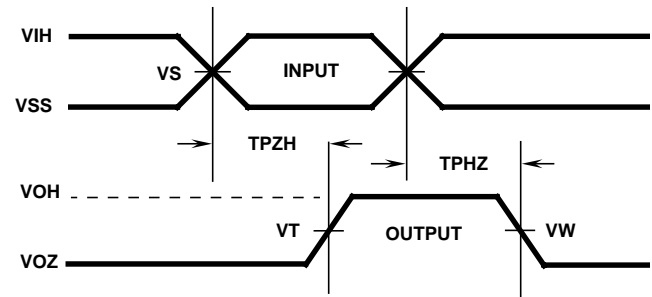

THREE-STATE HIGH VOLTAGE LEVELS

PARAMETER	HS-26C32RH	UNITS
VDD	4.50	V
VIH	4.50	V
VS	2.25	V
VT	50	%
VW	VOH - 0.5	V
GND	0	V

Three-State Low Load Circuit

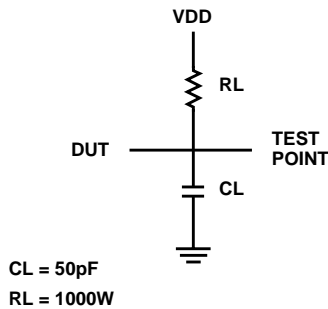

Three-State High Load Circuit

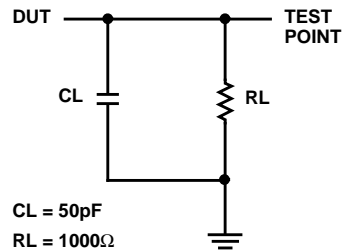

HS-26C32RH

Metallization Topology

DIE DIMENSIONS:
84mils x 130 mils
(2140 μ m x 3290 μ m)

METALLIZATION:
M1: Mo/Tiw
Thickness: 5800 \AA
M2: Al/Si/Cu
Thickness: 5800 \AA

GLASSIVATION:
Type: SiO₂
Thickness: 10k \AA \pm 1k \AA

WORST CASE CURRENT DENSITY:
<2.0 x 10⁵A/cm²

BOND PAD SIZE: 110 μ m x 100 μ m

Metallization Mask Layout

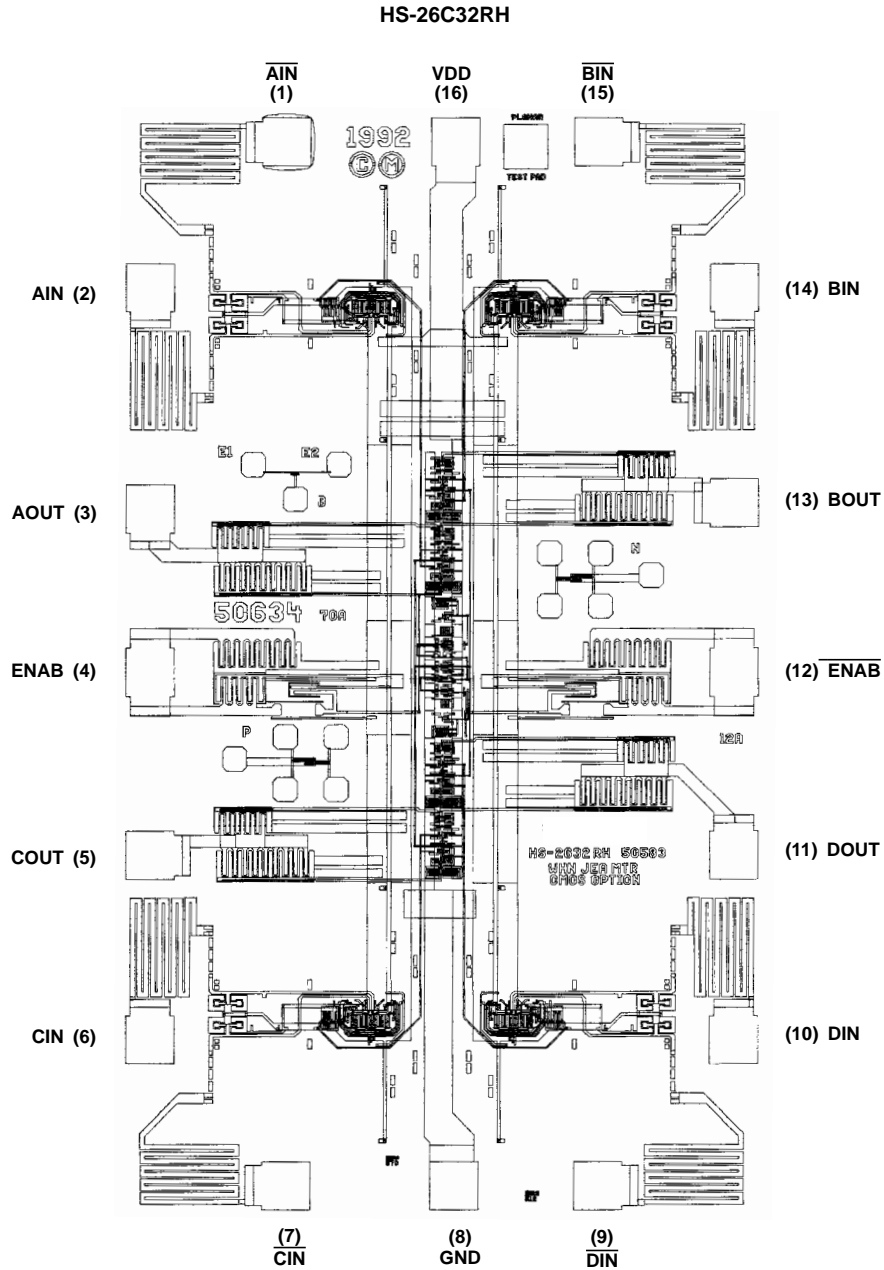

All Intersil semiconductor products are manufactured, assembled and tested under **ISO9000** quality systems certification.

Intersil products are sold by description only. Intersil Corporation reserves the right to make changes in circuit design and/or specifications at any time without notice. Accordingly, the reader is cautioned to verify that data sheets are current before placing orders. Information furnished by Intersil is believed to be accurate and reliable. However, no responsibility is assumed by Intersil or its subsidiaries for its use; nor for any infringements of patents or other rights of third parties which may result from its use. No license is granted by implication or otherwise under any patent or patent rights of Intersil or its subsidiaries.

For information regarding Intersil Corporation and its products, see web site <http://www.intersil.com>

Sales Office Headquarters

NORTH AMERICA

Intersil Corporation
P. O. Box 883, Mail Stop 53-204
Melbourne, FL 32902
TEL: (407) 727-9207
FAX: (407) 724-7240

EUROPE

Intersil SA
Mercure Center
100, Rue de la Fusee
1130 Brussels, Belgium
TEL: (32) 2.724.2111
FAX: (32) 2.724.22.05

ASIA

Intersil (Taiwan) Ltd.
Taiwan Limited
7F-6, No. 101 Fu Hsing North Road
Taipei, Taiwan
Republic of China
TEL: (886) 2 2716 9310
FAX: (886) 2 2715 3029

This datasheet has been downloaded from:

www.DatasheetCatalog.com

Datasheets for electronic components.



LittleDiode supplies new, hard to find or obsolete electronic components and semiconductors all over the world.

With over two million different components listed you are sure to find the part you need.

Feel free to visit us today at our online store:

LittleDiode.com

Looking forward to providing you with the best possible service.