

**Radiation Hardened CMOS 8-Bit Flash Analog-to-Digital Converter**

The Intersil HS-9008RH is a CMOS 8-Bit Flash Converter designed for space applications where relatively low power, exceptional accuracy and very fast conversion speeds are a necessity.

The HS-9008RH design differs substantially from most other available Flash Converters as it employs fully differential analog input sampling networks and amplifiers, as well as regenerative, offset nulled (error correcting) comparators. These circuit techniques improve noise performance and render the circuit much less sensitive to process and radiation induced device parametric shifts. Outstanding integral and differential linearity error is achieved through the use of a metal film resistor network which exhibits >10-bit linearity without trim. As a result of these innovations, the device operates with a single fixed reference supply as opposed to the multiple, adjustable references used in similar devices.

This combination of features makes the HS-9008RH one of the best 8-Bit Flash Converters available in the Commercial, Military or Rad Hard markets.

**Specifications for Rad Hard QML devices are controlled by the Defense Supply Center in Columbus (DSCC). The SMD numbers listed here must be used when ordering.**

**Detailed Electrical Specifications for these devices are contained in SMD 5962-96696. A "hot-link" is provided on our homepage for downloading.**  
<http://www.intersil.com/spacedefense/space.htm>

**Ordering Information**

ORDERING NUMBER	INTERNAL MKT. NUMBER	TEMP. RANGE (°C)
5962F9669601QXC	HS1-9008RH-8	-55 to 125
5962F9669601QYC	HS9-9008RH-8	-55 to 125
5962F9669601VXC	HS1-9008RH-Q	-55 to 125
5962F9669601VYC	HS9-9008RH-Q	-55 to 125
HS1-9008RH/Proto	HS1-9008RH/Proto	-55 to 125
HS9-9008RH/Proto	HS9-9008RH/Proto	-55 to 125
HS0-9008RH-Q	HS0-9008RH-Q	25

**Features**

- Electrically Screened to SMD # 5962-96696
- QML Qualified per MIL-PRF-38535 Requirements
- Excellent Noise Rejection - Fully Differential Design
- Superior Linearity . . . . . 0.5 LSB Typ
- Single Reference Supply
- Low Power . . . . . 330mW Typ
- Sampling Rate (50ns Conversion Time). . . . . 20MHz
- Total Dose Hardness . . . . . 300kRAD
- Available with QML Class V or Class Q Screening

**Pinouts**

**HS-9008RH (SBDIP) CDIP2-T28**  
TOP VIEW

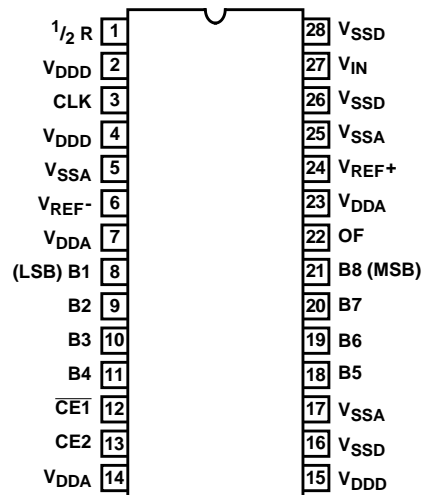

**HS-900RH (FLATPACK) CDFP3-F28**  
TOP VIEW

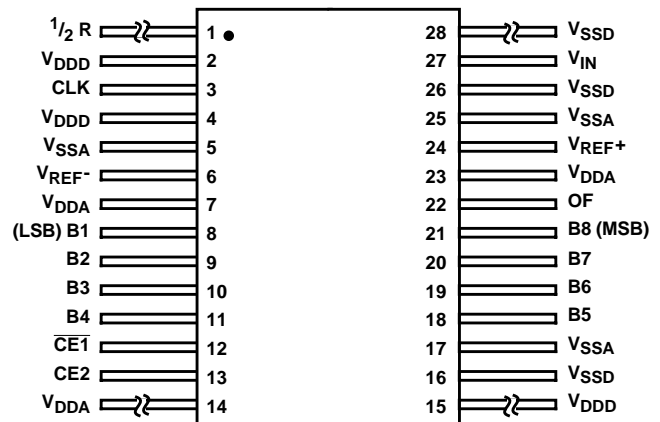

**Pin Descriptions**

SBDIP/ FLATPACK PACKAGE PIN	NAME	DESCRIPTION
8	B1	(LSB) Output Data Bits
9	B2	Output Data Bits
10	B3	Output Data Bits
11	B4	Output Data Bits
18	B5	Output Data Bits
19	B6	Output Data Bits
20	B7	Output Data Bits
21	B8	(MSB) Output Data Bits
22	OF	Overflow
16, 26, 28	V <sub>SSD</sub>	Digital Ground
2, 4, 15	V <sub>DDD</sub>	Digital Supply
13	CE2	Three-State Output Enable
12	$\overline{\text{CE1}}$	Three-State Output Enable
6	V <sub>REF-</sub>	Negative Reference Input
27	V <sub>IN</sub>	Analog Signal In
5, 17, 25	V <sub>SSA</sub>	Analog Ground
3	CLK	Clock Input
1	1/2 R	Reference Midpoint
24	V <sub>REF+</sub>	Positive Reference Input
7, 14, 23	V <sub>DDA</sub>	Analog Supply

TRUTH TABLE

CE1	CE2	B1 - B8	OF
0	1	Valid	Valid
1	1	Three-State	Valid
X	0	Three-State	Three-State

Functional Diagram

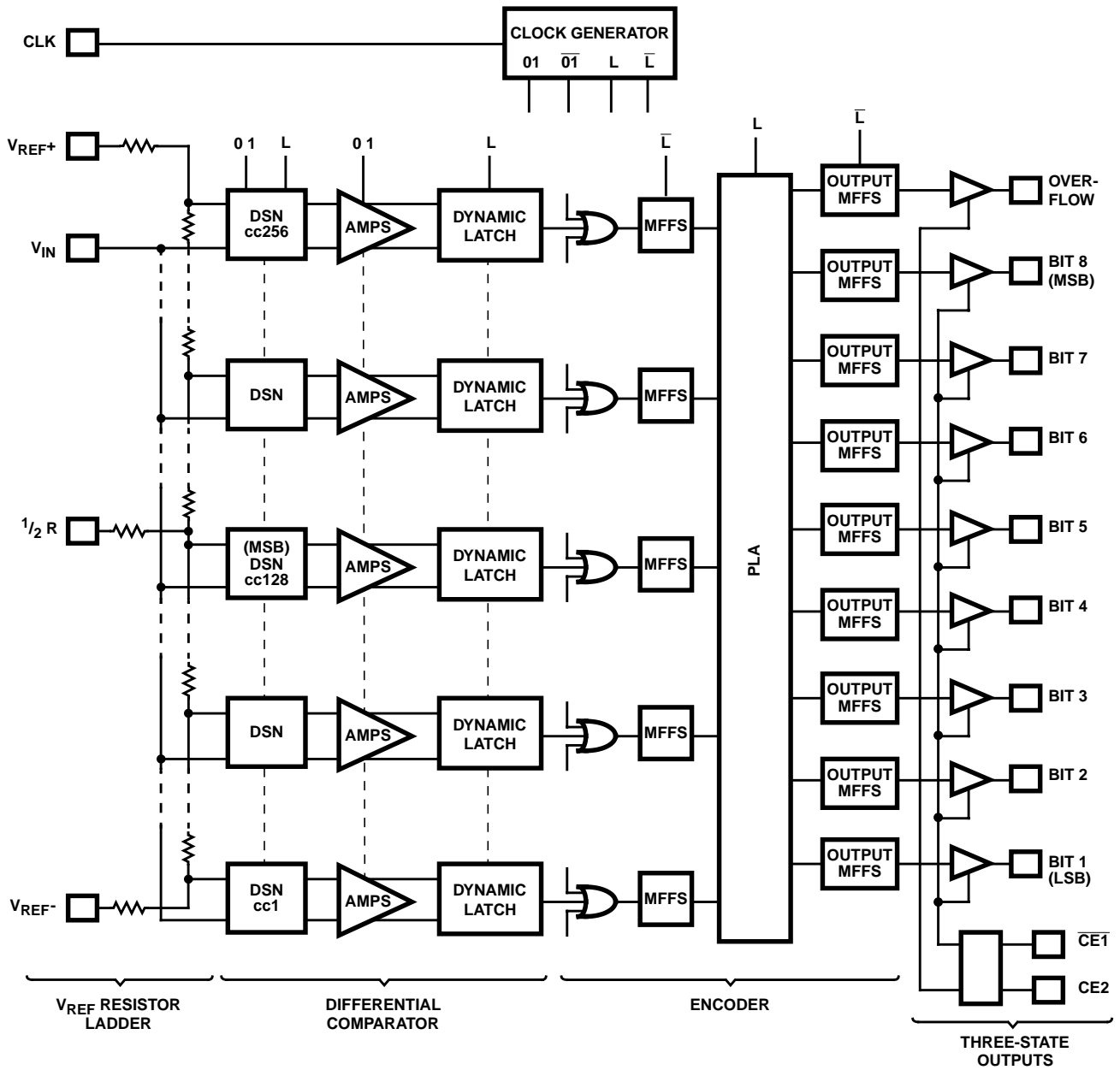

**Die Characteristics**

**DIE DIMENSIONS:**

180 mils x 197 mils x 21 ±1 mils

**INTERFACE MATERIALS:**

**Glassivation:**

Type: SiO<sub>2</sub>  
 Thickness: 8kÅ ±1kÅ

**Top Metallization:**

Metal 1 - Type: Moly/TiW  
 Thickness: 5.8kÅ ±10%  
 Metal 2- Type: Al/Si/Cu  
 Thickness: 10kÅ ±10%

**Backside Finish:**

Silicon

**ASSEMBLY RELATED INFORMATION:**

**Substrate Potential (Powered Up):**

V<sub>DD</sub>

**ADDITIONAL INFORMATION:**

**Worst Case Current Density:**

Metal 1 - Designs using the Intersil AVLSI-1RA process take advantage of the superior current carrying capabilities of Moly.TiW. The current density limit established by Intersil Reliability is 5.0 x 10<sup>5</sup> A/cm<sup>2</sup>  
 Metal 2 - 1.63 x 10<sup>5</sup> A/cm<sup>2</sup>

**Process:**

AVLSI1RA

**Metallization Mask Layout**

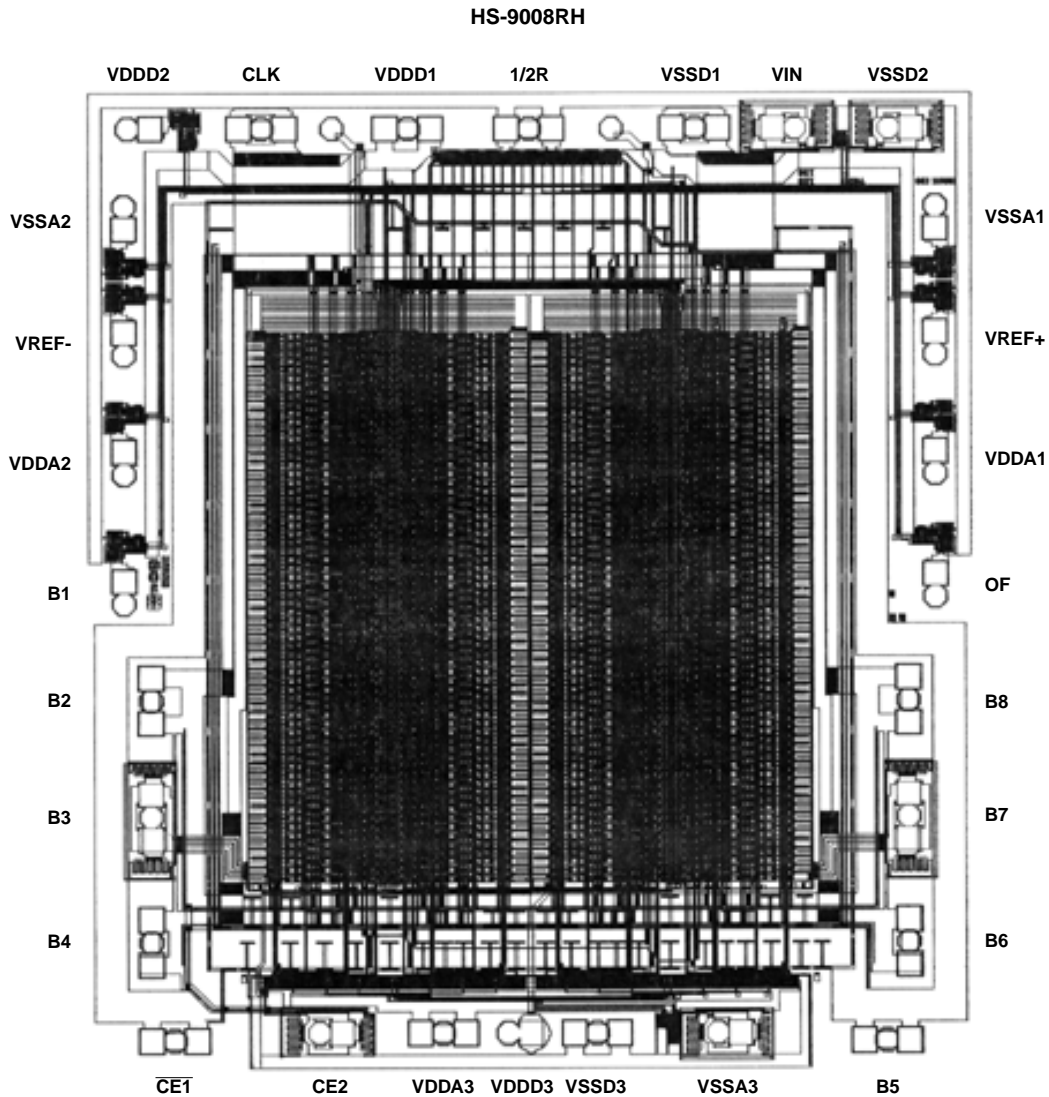

All Intersil semiconductor products are manufactured, assembled and tested under **ISO9000** quality systems certification.

*Intersil semiconductor products are sold by description only. Intersil Corporation reserves the right to make changes in circuit design and/or specifications at any time without notice. Accordingly, the reader is cautioned to verify that data sheets are current before placing orders. Information furnished by Intersil is believed to be accurate and reliable. However, no responsibility is assumed by Intersil or its subsidiaries for its use; nor for any infringements of patents or other rights of third parties which may result from its use. No license is granted by implication or otherwise under any patent or patent rights of Intersil or its subsidiaries.*

For information regarding Intersil Corporation and its products, see web site <http://www.intersil.com>

### **Sales Office Headquarters**

#### **NORTH AMERICA**

Intersil Corporation  
P. O. Box 883, Mail Stop 53-204  
Melbourne, FL 32902  
TEL: (407) 724-7000  
FAX: (407) 724-7240

#### **EUROPE**

Intersil SA  
Mercure Center  
100, Rue de la Fusee  
1130 Brussels, Belgium  
TEL: (32) 2.724.2111  
FAX: (32) 2.724.22.05

#### **ASIA**

Intersil (Taiwan) Ltd.  
7F-6, No. 101 Fu Hsing North Road  
Taipei, Taiwan  
Republic of China  
TEL: (886) 2 2716 9310  
FAX: (886) 2 2715 3029

This datasheet has been downloaded from:

[www.DatasheetCatalog.com](http://www.DatasheetCatalog.com)

Datasheets for electronic components.



LittleDiode supplies new, hard to find or obsolete electronic components and semiconductors all over the world.

With over two million different components listed you are sure to find the part you need.

Feel free to visit us today at our online store:

**[LittleDiode.com](http://LittleDiode.com)**

Looking forward to providing you with the best possible service.