

FULLY PROTECTED POWER MOSFET SWITCH

Features

- Controlled slew rate reduces EMI
- Over temperature protection with auto-restart
- Linear current-limit protection
- Active drain-to-source clamp
- ESD protection
- Lead compatible with standard Power MOSFET
- Low operating input current
- Monolithic construction

Description

The IRSF3021 Lamp and DC motor driver is a fully protected three terminal monolithic Smart Power MOSFET that features current limiting, over-temperature protection, ESD protection and over-voltage protection.

The on-chip protection circuit limits the drain current at 5.5A (typical) in the on-state, when the load is short circuited. The over-temperature circuitry turns off the Power MOSFET when the junction temperature exceeds 165°C (typical). The device restarts automatically once it has cooled down below the reset temperature.

The IRSF3021 is specifically designed for driving loads that require overload protection and in-rush current control while operating in automotive and industrial environments. Targeted applications include resistive loads such as lamps or capacitive loads such as airbag squibs and DC motor drives.

Product Summary

$V_{ds(clamp)}$	50V
$R_{ds(on)}$	200m Ω
I_{lim}	5.5A
$T_{j(sd)}$	165°C
EAS	200mJ

Applications

- Cabin Lighting
- Airbag System
- Programmable Logic Controller
- DC Motor Drive

Packages

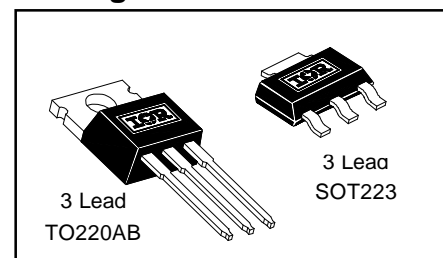

Block Diagram

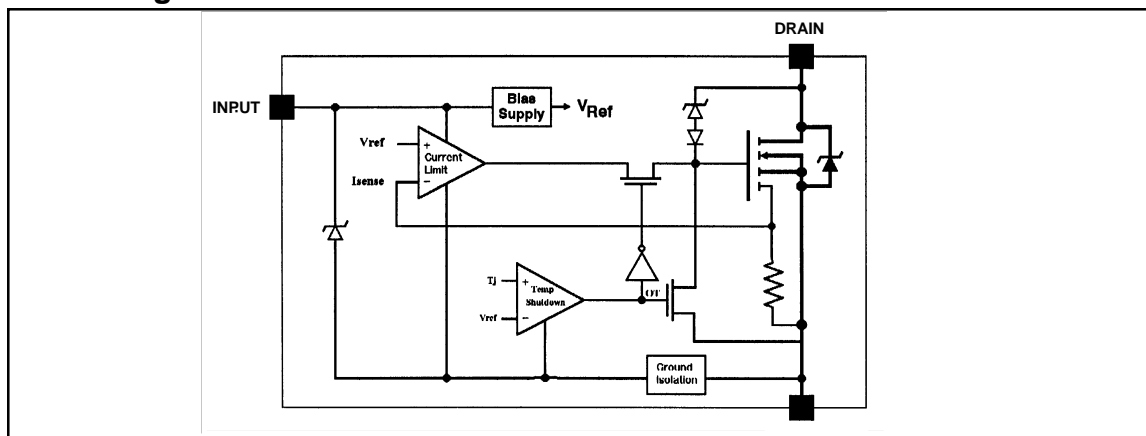

Absolute Maximum Ratings

Absolute Maximum Ratings indicate sustained limits beyond which damage to the device may occur. ($T_C = 25^\circ\text{C}$ unless otherwise specified.)

Symbol	Parameter	Min.	Max.	Units	Test Conditions
$V_{ds, max}$	Continuous drain to source voltage	—	50	V	
$V_{in, max}$	Continuous input voltage	-0.3	10		
I_{ds}	Continuous drain current	—	self limited	A	
P_d	Power dissipation	—	30	W	$T_C \leq 25^\circ\text{C}$, TO220
		—	3	W	$T_C \leq 25^\circ\text{C}$, SOT223
EAS	Unclamped single pulse inductive energy ^②	—	200	mJ	
V_{esd1}	Electrostatic discharge voltage (Human Body Model)	—	4000	V	100pF, 1.5k Ω
V_{esd2}	Electrostatic discharge voltage (Machine Model)	—	1000		200pF, 0 Ω
T_{Jop}	Operating junction temperature range	-55	150	°C	
T_{Stg}	Storage temperature range	-55	150		
T_L	Lead temperature (soldering, 10 seconds)	—	300		

Static Electrical Characteristics

($T_C = 25^\circ\text{C}$ unless otherwise specified.)

Symbol	Parameter	Min.	Typ.	Max.	Units	Test Conditions
$V_{ds, clamp}$	Drain to source clamp voltage	50	56	65	V	$I_{ds} = 6\text{A}$, $t_p = 700 \mu\text{S}$
$R_{ds(on)}$	Drain to source on resistance	—	155	200	m Ω	$V_{in} = 5\text{V}$, $I_{ds} = 2\text{A}$
I_{dss}	Drain to source leakage current	—	—	250	μA	$V_{ds} = 40\text{V}$, $V_{in} = 0\text{V}$
V_{th}	Input threshold voltage	1.0	2.0	3.0	V	$V_{ds} = V_{in}$, $I_{ds} + I_{in} = 10\text{mA}$
$I_{i, on}$	Input supply current (Normal Operation)	—	100	300	μA	$V_{in} = 5\text{V}$
$I_{i, off}$	Input supply current (Protection Mode)	—	250	500	μA	$V_{in} = 5\text{V}$
$V_{in, clamp}$	Input clamp voltage	9	10	—	V	$I_{in} = 1\text{mA}$
V_{sd}	Body-drain diode forward drop ^③	—	1.5	—		$I_{ds} = -2\text{A}$, $R_{in} = 1\text{k}\Omega$

Thermal Characteristics

Symbol	Parameter	Min.	Typ.	Max.	Units	Test Conditions
R_{thjc}	Junction to case	—	—	4	°C/W	TO-220AB
R_{thja}	Junction to ambient	—	—	60		
R_{thjc}	Junction to case	—	—	40	°C/W	SOT-223
R_{thja}	Junction to PCB ^①	—	—	60		

NOTES:

- ① When mounted on a 1" square PCB (FR-4 or G10 material). For recommended footprint and soldering techniques, refer to International Rectifier Application Note AN-994.
- ② E_{AS} is tested with a constant current source of 6A applied for 700 μS with $V_{in} = 0\text{V}$ and starting $T_j = 25^\circ\text{C}$.
- ③ Input current must be limited to less than 5mA with a 1k Ω resistor in series with the input when the Body-Drain Diode is forward biased.

Switching Electrical Characteristics

($V_{CC} = 14V$, resistive load (R_L) = 10 Ω , R_{in} = 100 Ω . Specifications measured at $T_C = 25^\circ C$ unless otherwise specified.)

Symbol	Parameter	Min.	Typ.	Max.	Units	Test Conditions
t_{don}	Turn-on delay time	—	10	50	μs	$V_{in} = 0V$ to 5V, 50% to 90%
t_r	Rise Time	—	30	80		$V_{in} = 0V$ to 5V, 90% to 10%
t_{doff}	Turn-off delay time	—	20	60		$V_{in} = 5V$ to 0V, 50% to 10%
t_f	Fall time	—	15	50		$V_{in} = 5V$ to 0V, 10% to 90%
SR	Output positive slew rate	-4	—	4	V/ μs	$V_{in} = 0V$ to 5V, +dVds/dt
SR	Output negative slew rate	-4	—	4		$V_{in} = 5V$ to 0V, -dVds/dt

Protection Characteristics

($T_C = 25^\circ C$ unless otherwise specified.)

Symbol	Parameter	Min.	Typ.	Max.	Units	Test Conditions
$I_{ds(lim)}$	Current limit	3.0	5.5	8.0	A	$V_{in} = 5V$, $V_{ds} = 14V$
$T_{j(sd)}$	Over temperature shutdown threshold	155	165	—	$^\circ C$	$V_{in} = 5V$, $I_{ds} = 2A$
$V_{protect}$	Min. input voltage for over-temp function	—	3	—	V	
t_{lres}	Current limit response time	—	TBD	—	μs	
I_{peak}	Peak short circuit current	—	10	—	A	
t_{Tresp}	Over-temperature response time	—	TBD	—	μs	

Lead Assignments

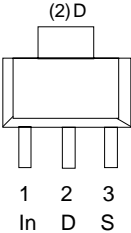
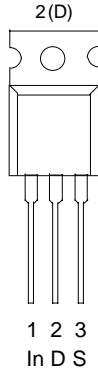
 <p>3 Lead - SOT223</p>	 <p>3 Lead - TO220</p>
IRSF3021L	IRSF3021
Part Number	

Case Outline - SOT-223

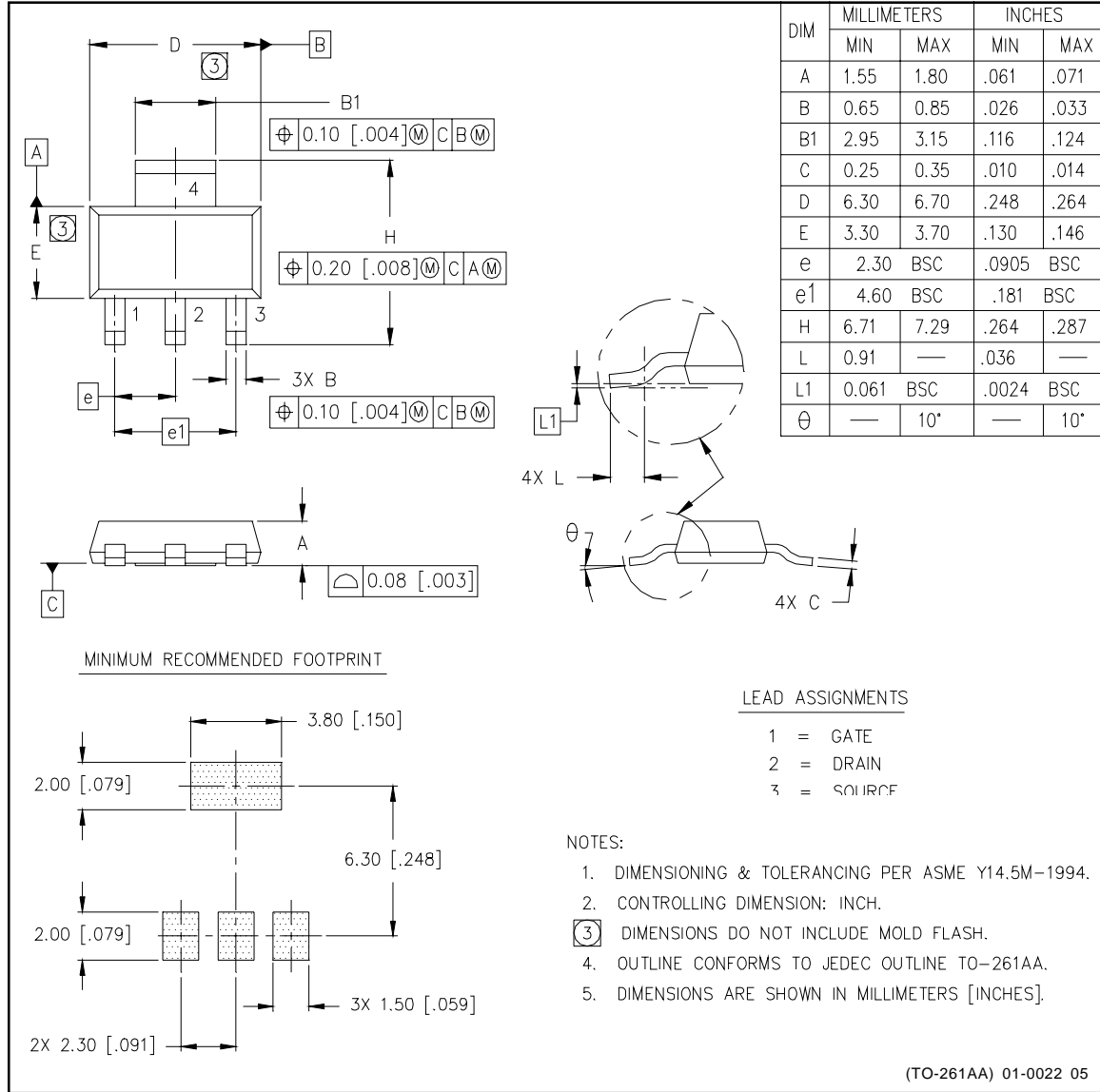

Case Outline 3 Lead - TO220

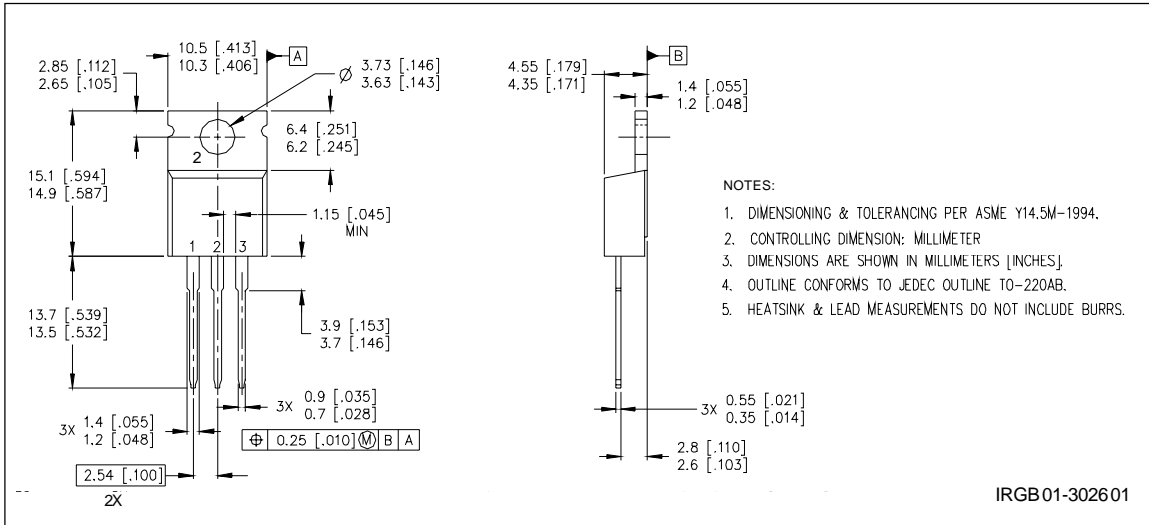

Tape & Reel - SOT223

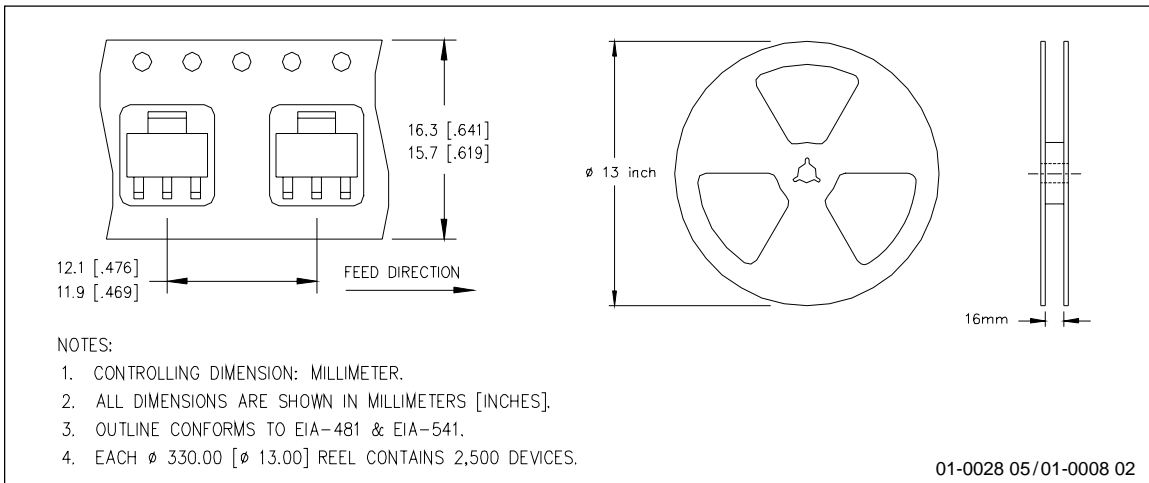



LittleDiode supplies new, hard to find or obsolete electronic components and semiconductors all over the world.

With over two million different components listed you are sure to find the part you need.

Feel free to visit us today at our online store:

LittleDiode.com

Looking forward to providing you with the best possible service.