

NEC
ELECTRON DEVICE

MOS FIELD EFFECT TRANSISTOR

2SK823

FAST SWITCHING
N-CHANNEL SILICON POWER MOS FET

PACKAGE DIMENSIONS
(Unit: mm)

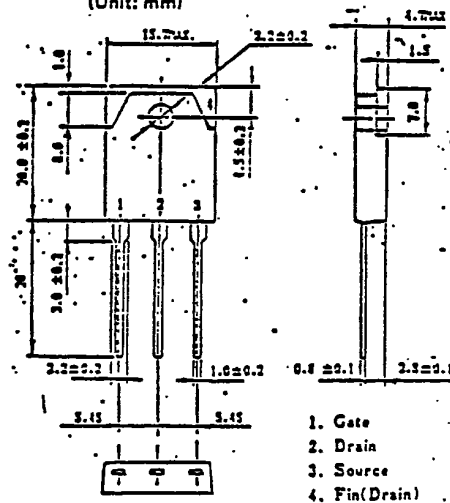

Features

Suitable for switching power supplies,
actuator controls and pulse circuits
Low $R_{DS(on)}$

Absolute Maximum Ratings ($T_a=25^\circ\text{C}$)

Drain to Source Voltage	V_{DS}	250V
Gate to Source Voltage	V_{GS}	$\pm 20V$
Continuous Drain Current	$I_{D(DC)}$	$\pm 25A$
Pulse Drain Current	$I_{D(pulse)}$	* $\pm 100A$
Total Power Dissipation	P_T	3.0W
Total Power Dissipation	P_{T*}	120W
Channel Temperature	T_{ch}	150 $^\circ\text{C}$
Storage Temperature	T_{stg}	-55to+150 $^\circ\text{C}$
* $P_W \leq 100 \mu\text{s}$, Duty Cycle $\leq 2\%$		
** $T_c=25^\circ\text{C}$		

Electrical Characteristics ($T_a=25^\circ\text{C}$)

Characteristics	Symbol	Min.	Typ.	Max.	Unit	Test Conditions
Drain Leakage Current	I_{DSS}			100	μA	$V_{DS}=250V, V_{GS}=0$
Gate to Source Leakage Current	I_{GSS}			± 100	nA	$V_{GS}=\pm 20V, V_{DS}=0$
Gate to Source Cutoff Voltage	$V_{GS(off)}$	1.5		3.5	V	$V_{DS}=10V, I_D=1.0\text{mA}$
Forward Transfer Admittance	yfs	5.0			S	$V_{DS}=10V, I_D=13A$
Drain to Source On-State Resistance	$R_{DS(on)}$		0.12	0.15	Ω	$V_{GS}=10V, I_D=13A$
Input Capacitance	C_{iss}		2950		pF	$V_{DS}=10V,$
Output Capacitance	C_{oss}		990		pF	$V_{GS}=0,$
Reverse Transfer Capacitance	C_{rss}		450		pF	$f=1.0\text{MHz}$
Turn-On Delay Time	$t_{d(on)}$		25		ns	$I_D=13A$
Rise Time	t_r		85		ns	$V_{GS(on)}=10V,$
Turn-Off Delay Time	$t_{d(off)}$		115		ns	$V_{CC}=150V,$
Fall Time	t_f		85		ns	$R_L=11.5 \Omega$

TURN-ON AND TURN-OFF TIME TEST CIRCUIT

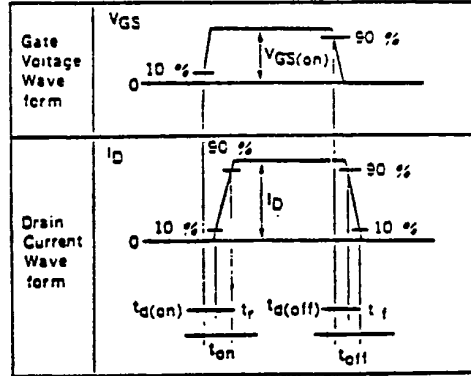
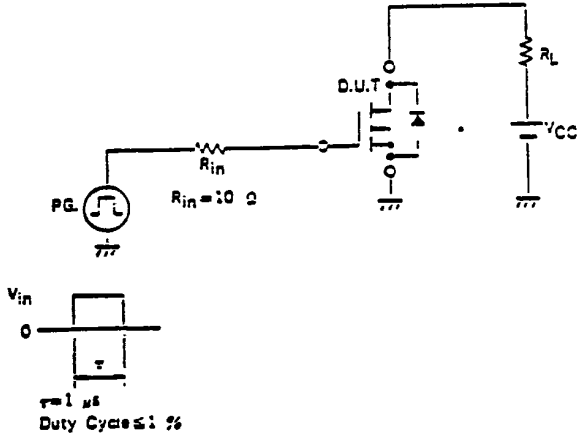

DERATING FACTOR OF FORWARD BIAS SAFE OPERATING AREA

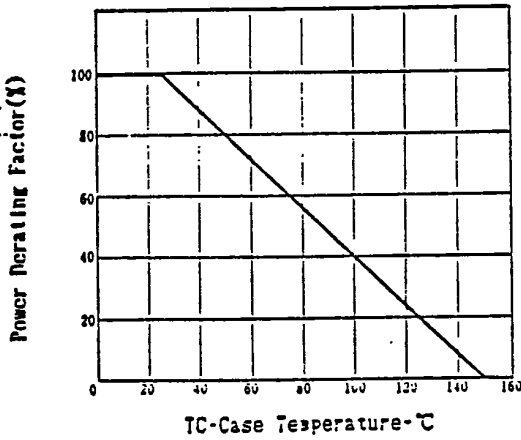

FORWARD BIAS SAFE OPERATING AREA

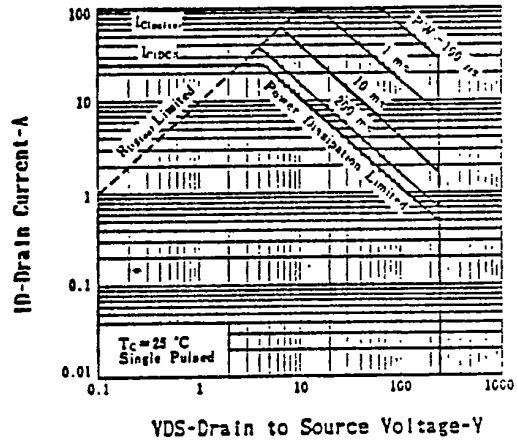

TOTAL POWER DISSIPATION vs. CASE TEMPERATURE

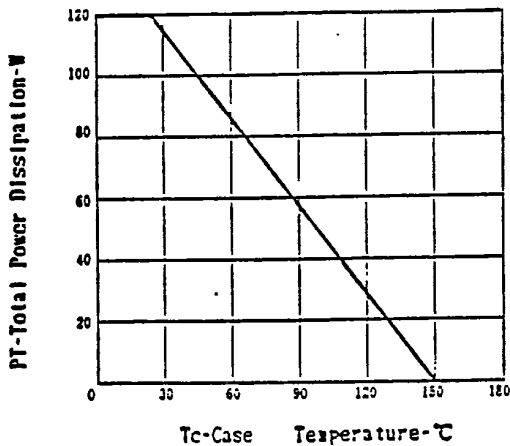

DRAIN CURRENT vs. DRAIN TO SOURCE VOLTAGE

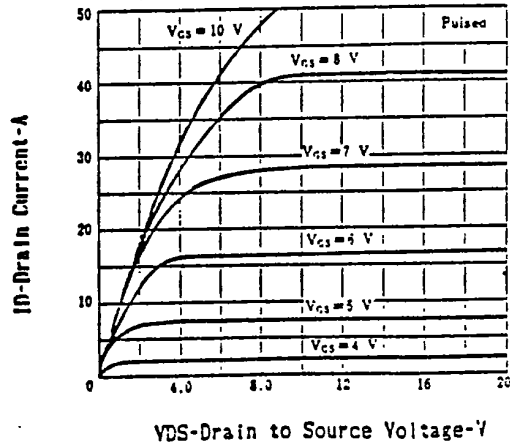

6427525 N E C ELECTRONICS INC
FORWARD TRANSFER ADMITTANCE
vs. DRAIN CURRENT

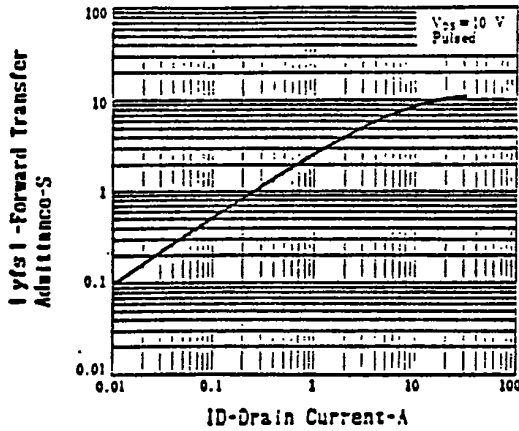

98D 18995 D T-39-13
SOURCE TO DRAIN DIODE
FORWARD VOLTAGE

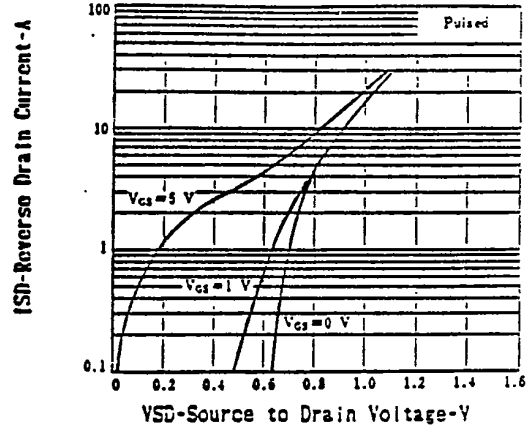

CAPACITANCE vs. DRAIN TO
SOURCE VOLTAGE

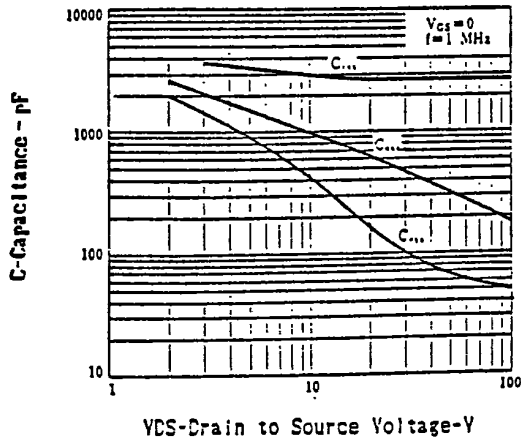

DRAIN TO SOURCE ON-STATE RESISTANCE
vs. GATE TO SOURCE VOLTAGE

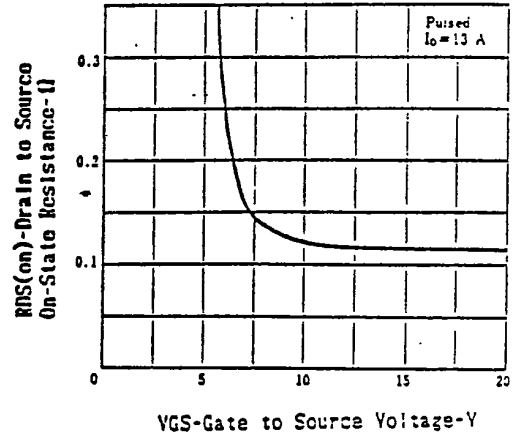

DRAIN TO SOURCE ON-STATE RESISTANCE
vs. CHANNEL TEMPERATURE

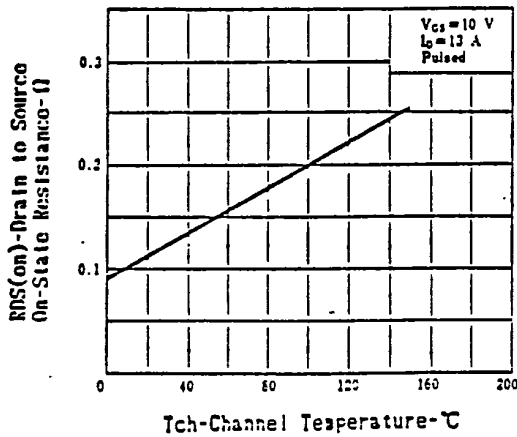

DRAIN TO SOURCE ON-STATE RESISTANCE
vs. DRAIN CURRENT

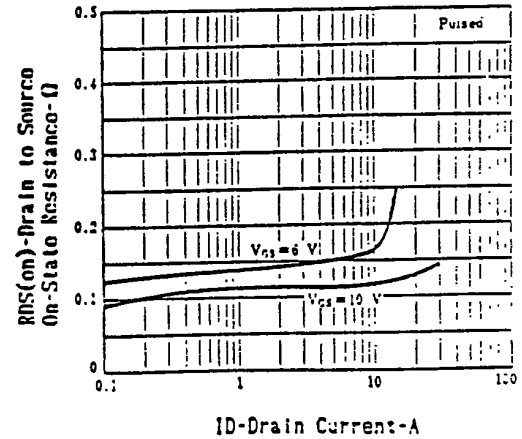

TRANSFER CHARACTERISTICS

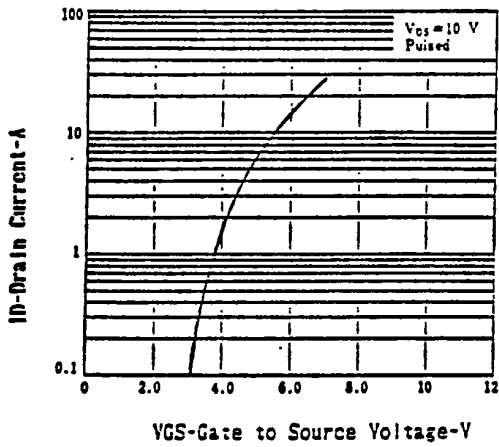

GATE TO SOURCE CUTOFF VOLTAGE vs. CHANNEL TEMPERATURE

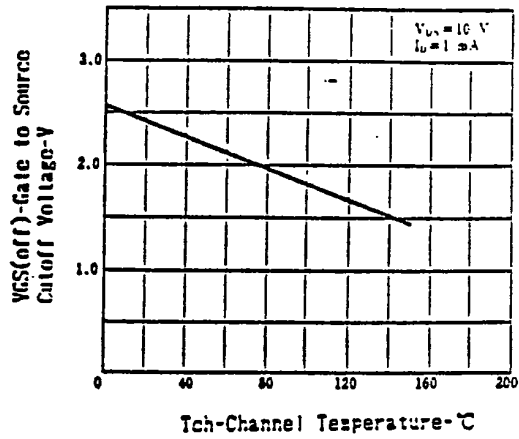

SWITCHING CHARACTERISTICS

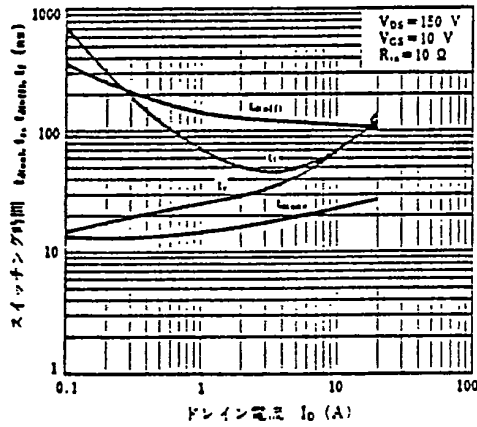

NEC Corporation

INTERNATIONAL ELECTRON DEVICES DIV.
 NEC Building, 33-1, Shiba Gochome
 Minato-ku, Tokyo 108, Japan
 Tel: Tokyo 454-1111
 Telex Address: NECTOK J22686
 Cable Address: MICROPHONE TOKYO

Printed in Japan



LittleDiode supplies new, hard to find or obsolete electronic components and semiconductors all over the world.

With over two million different components listed you are sure to find the part you need.

Feel free to visit us today at our online store:

LittleDiode.com

Looking forward to providing you with the best possible service.