

# LM2991QML

## Negative Low Dropout Adjustable Regulator

### General Description

The LM2991 is a low dropout adjustable negative regulator with a output voltage range between  $-2V$  to  $-25V$ . The LM2991 provides up to 1A of load current and features a  $\overline{ON/OFF}$  pin for remote shutdown capability.

The LM2991 uses new circuit design techniques to provide a low dropout voltage, low quiescent current and low temperature coefficient precision reference. The dropout voltage at 1A load current is typically 0.6V and a guaranteed worst-case maximum of 1V over the entire operating temperature range. The quiescent current is typically 1 mA with a 1A load current and an input-output voltage differential greater than 3V. A unique circuit design of the internal bias supply limits the quiescent current to only 9 mA (typical) when the regulator is in the dropout mode ( $V_O - V_I \leq 3V$ ).

The LM2991 is short-circuit proof, and thermal shutdown includes hysteresis to enhance the reliability of the device when inadvertently overloaded for extended periods.

### Features

- Output voltage adjustable from  $-2V$  to  $-25V$
- Output current in excess of 1A
- Dropout voltage typically 0.6V at 1A load
- Low quiescent current
- Internal short circuit current limit
- Internal thermal shutdown with hysteresis
- TTL, CMOS compatible  $\overline{ON/OFF}$  switch
- Functional complement to the LM2941 series

### Applications

- Post switcher regulator
- Local, on-card, regulation
- Battery operated equipment

### Ordering Information

NS Part Number	SMD Part Number	NS Package Number	Package Description
LM2991J-QML	5962-9650501QEA	J16A	16LD Ceramic Dip
LM2991J-QMLV	5962-9650501VEA	J16A	16LD Ceramic Dip
LM2991WG-QML	5962-9650501QXA	WG16A	16LD Ceramic SOIC

### Connection Diagrams

16-Lead Ceramic Dual-in-Line Package

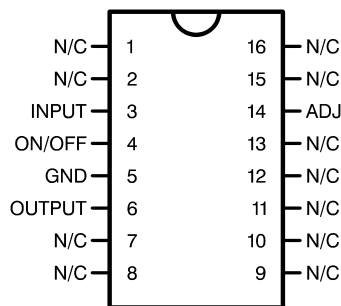

Top View  
See NS Package Number J16A

20158729

16-Lead Ceramic Surface-Mount Package

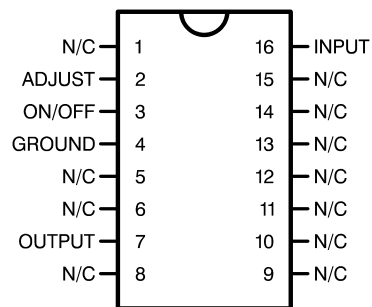

Top View  
See NS Package Number WG16A

20158730



**Absolute Maximum Ratings** (Note 1)

Input Voltage	-26V to +0.3V
Power Dissipation (Note 2)	Internally limited
Junction Temperature ( $T_{Jmax}$ )	150°C
Storage Temperature Range	$-65^{\circ}\text{C} \leq T_A \leq +150^{\circ}\text{C}$
Thermal Resistance	
$\theta_{JA}$	
Ceramic DIP (Still Air @ 0.5°C/W)	75°C/W
Ceramic DIP (500LF/Min Air flow @ 0.5°C/W)	35°C/W
Ceramic SOIC (Still Air @ 0.5°C/W)	119°C/W
Ceramic SOIC (500LF/Min Air flow @ 0.5°C/W)	73°C/W
$\theta_{JC}$ (Note 3)	
Ceramic DIP	5°C/W
Ceramic SOIC	3°C/W
Package Weight (Typical)	TBD
Lead Temperature (Soldering, 10 sec.)	260°C
ESD Susceptibility (Note 4)	1,500V

**Recommended Operating Conditions** (Note 1)

Operating Temperature Range ( $T_A$ )	$-55^{\circ}\text{C} \leq T_A \leq +125^{\circ}\text{C}$
Maximum Input Voltage (Operational)	-26V

**Quality Conformance Inspection**

Mil-Std-883, Method 5005 - Group A

Subgroup	Description	Temp °C
1	Static tests at	25
2	Static tests at	125
3	Static tests at	-55
4	Dynamic tests at	25
5	Dynamic tests at	125
6	Dynamic tests at	-55
7	Functional tests at	25
8A	Functional tests at	125
8B	Functional tests at	-55
9	Switching tests at	25
10	Switching tests at	125
11	Switching tests at	-55
12	Settling time at	25
13	Settling time at	125
14	Settling time at	-55

## LM2991 Electrical Characteristics

### DC Parameters

The following conditions apply, unless otherwise specified.

DC:  $V_I = -10V$ ,  $V_O = -3V$ ,  $I_O = 1A$ ,  $C_O = 47\mu F$ ,  $R_L = 2.7K\Omega$

Symbol	Parameter	Conditions	Notes	Min	Max	Units	Sub-groups
$V_{Ref}$	Reference Voltage	$5mA \leq I_O \leq 1A$		-1.234	-1.186	V	1
		$5mA \leq I_O \leq 1A$ , $V_O - 1V \geq V_I \geq -26V$		-1.27	-1.15	V	2, 3
$V_O$	Output Voltage Range				-3.0	V	1
		$V_I = -26V$		-24		V	1
				-25		V	2, 3
$V_{RLine}$	Line Regulation	$I_O = 5mA$ , $V_O - 1V \geq V_I \geq -26V$		-26	+26	mV	1, 2, 3
$V_{RLoad}$	Load Regulation	$50mA \leq I_O \leq 1A$		-12	+12	mV	1
				-15	+15	mV	2, 3
$V_{DO}$	Dropout Voltage	$I_O = 0.1A$ , $\Delta V_O \leq 100mV$			0.2	V	1
					0.3	V	2, 3
		$I_O = 1A$ , $\Delta V_O \leq 100mV$			0.8	V	1
					1.0	V	2, 3
$I_Q$	Quiescent Current	$I_O \leq 1A$			5.0	mA	1, 2, 3
	Dropout Quiescent Current	$V_I = V_O$ , $I_O \leq 1A$			50	mA	1, 2, 3
$V_{ON}$	Output Noise	10Hz - 100KHz, $I_O = 5mA$			450	$\mu V$	1
					500	$\mu V$	2, 3
	$\overline{ON}/OFF$ Input Voltage	$V_O : ON$			0.8	V	1, 2, 3
		$V_O : OFF$		2.4		V	1, 2, 3
	$\overline{ON}/OFF$ Input Current	$\overline{VON}/OFF = 0.8V$ ( $V_O : ON$ )			10	$\mu A$	1
					25	$\mu A$	2, 3
		$\overline{VON}/OFF = 2.4V$ ( $V_O : OFF$ )			100	$\mu A$	1
					150	$\mu A$	2, 3
$I_L$	Output Leakage Current	$V_I = -26V$ , $\overline{VON}/OFF = 2.4V$ , $V_O = 0V$			250	$\mu A$	1
					300	$\mu A$	2, 3
$I_{Limit}$	Current Limit	$V_O = 0V$		1.5	2.5	A	1
				1.0	4.0	A	2, 3

### AC Parameters

The following conditions apply, unless otherwise specified.

AC:  $V_I = -10V$ ,  $V_O = -3V$ ,  $I_O = 1A$ ,  $C_O = 47\mu F$ ,  $R_L = 2.7K\Omega$

Symbol	Parameter	Conditions	Notes	Min	Max	Units	Sub-groups
RR	Ripple Rejection	$V_{Ripple} = 1V_{RMS}$ , $F_{Ripple} = 1KHz$ , $I_O = 5mA$		50		dB	1

## LM2991 Electrical Characteristics (Continued)

### DC Drift Parameters

The following conditions apply, unless otherwise specified.

DC:  $V_I = -10V$ ,  $V_O = -3V$ ,  $I_O = 1A$ ,  $C_O = 47\mu F$ ,  $R_L = 2.7K\Omega$  Deltas not required on B-Level product. Deltas required for S-Level product ONLY.

Symbol	Parameter	Conditions	Notes	Min	Max	Units	Sub-groups
$V_{Ref}$	Reference Voltage	$5mA \leq I_O \leq 1A$			$\pm 20$	mV	1

**Note 1:** Absolute Maximum Ratings indicate limits beyond which damage to the device may occur. Operating Ratings indicate conditions for which the device is functional, but do not guarantee specific performance limits. For guaranteed specifications and test conditions, see the Electrical Characteristics. The guaranteed specifications apply only for the test conditions listed. Some performance characteristics may degrade when the device is not operated under the listed test conditions.

**Note 2:** The maximum power dissipation must be derated at elevated temperatures and is dictated by  $T_{Jmax}$  (maximum junction temperature),  $\theta_{JA}$  (package junction to ambient thermal resistance), and  $T_A$  (ambient temperature). The maximum allowable power dissipation at any temperature is  $P_{Dmax} = (T_{Jmax} - T_A)/\theta_{JA}$  or the number given in the Absolute Maximum Ratings, whichever is lower.

**Note 3:** The package material for these devices allows much improved heat transfer over our standard ceramic packages. In order to take full advantage of this improved heat transfer, heat sinking must be provided between the package base (directly beneath the die), and either metal traces on, or thermal vias through, the printed circuit board. Without this additional heat sinking, device power dissipation must be calculated using  $\theta_{JA}$ , rather than  $\theta_{JC}$ , thermal resistance. It must not be assumed that the device leads will provide substantial heat transfer out the package, since the thermal resistance of the leadframe material is very poor, relative to the material of the package base. The stated  $\theta_{JC}$  thermal resistance is for the package material only, and does not account for the additional thermal resistance between the package base and the printed circuit board. The user must determine the value of the additional thermal resistance and must combine this with the stated value for the package, to calculate the total allowed power dissipation for the device. The user must determine the value of the additional thermal resistance and must combine this with the stated value for the package, to calculate the total allowed power dissipation for the device.

**Note 4:** Human body model, 1.5 k $\Omega$  in series with 100 pF.

# Typical Performance Characteristics

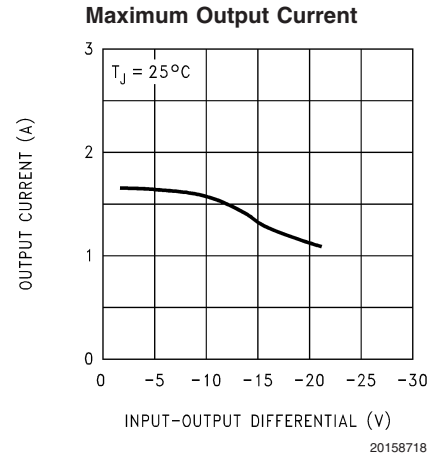
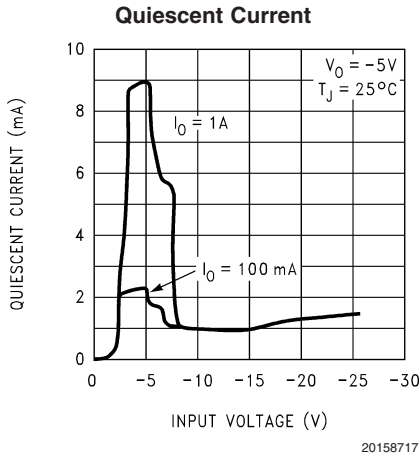
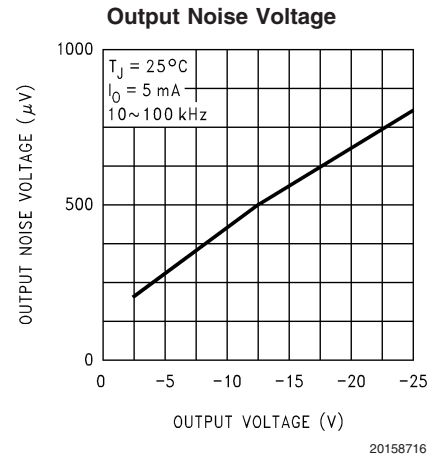
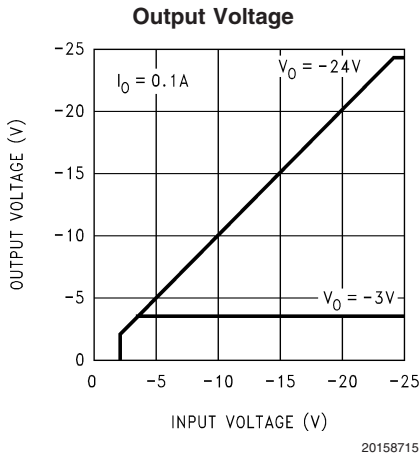
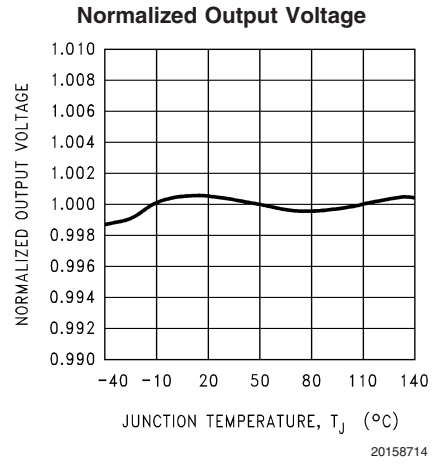
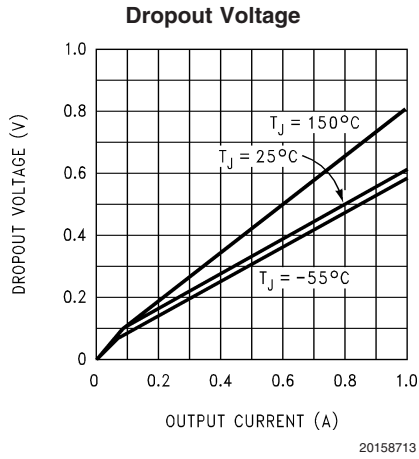

Typical Performance Characteristics (Continued)

Line Transient Response

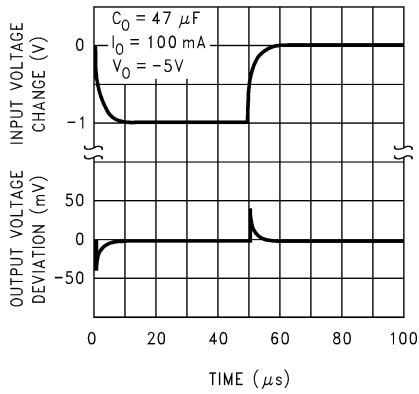

20158719

Load Transient Response

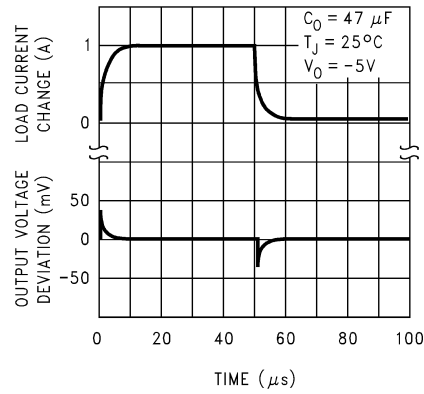

20158720

Maximum Output Current

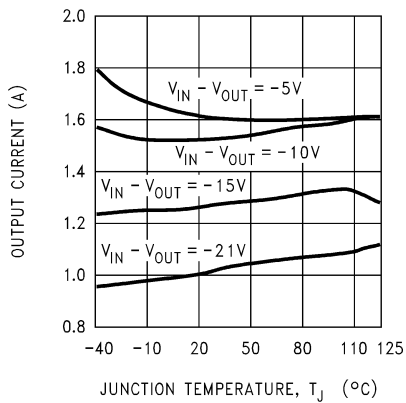

20158721

Ripple Rejection

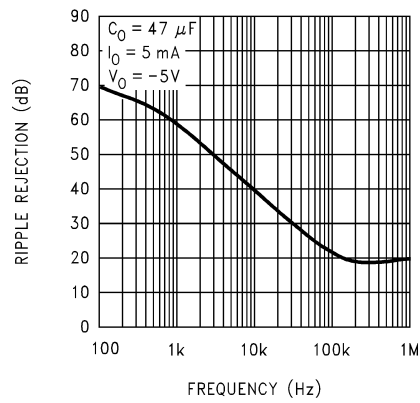

20158722

Output Impedance

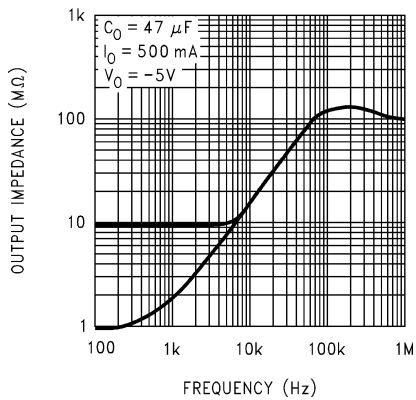

20158723

$\overline{\text{ON}}$  /OFF Control Voltage

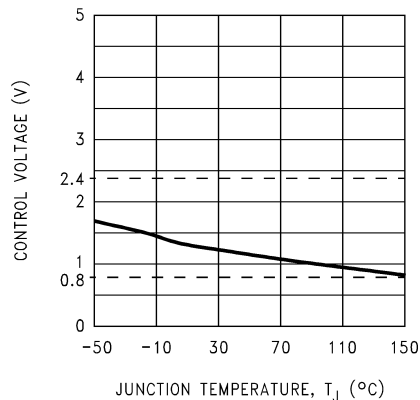

20158724

## Typical Performance Characteristics (Continued)

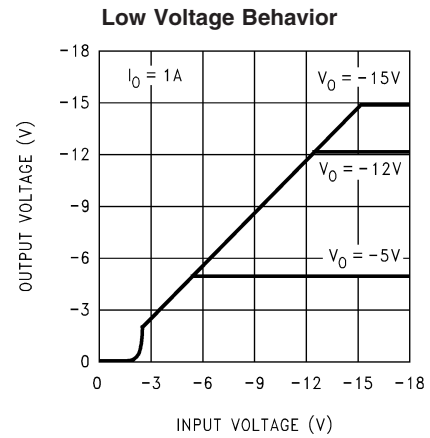
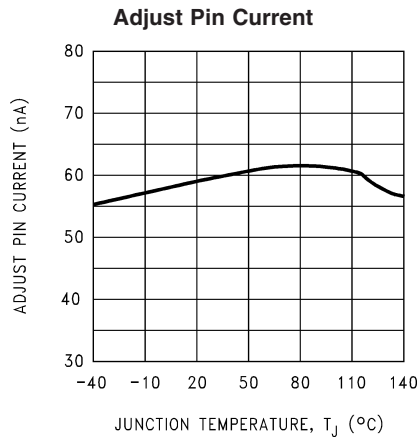

## Application Hints

### EXTERNAL CAPACITORS

Like any low-dropout regulator, external capacitors are required to stabilize the control loop. These capacitors must be correctly selected for proper performance.

### INPUT CAPACITOR

An input capacitor is required if the regulator is located more than 6" from the input power supply filter capacitor (or if no other input capacitor is present).

A solid Tantalum or ceramic capacitor whose value is at least 1  $\mu\text{F}$  is recommended, but an aluminum electrolytic ( $\geq 10 \mu\text{F}$ ) may be used. However, aluminum electrolytics should not be used in applications where the ambient temperature can drop below 0°C because their internal impedance increases significantly at cold temperatures.

### OUTPUT CAPACITOR

The output capacitor must meet the ESR limits shown in the graph, which means it must have an ESR between about 25 m $\Omega$  and 10 $\Omega$ .

A solid Tantalum (value  $\geq 1 \mu\text{F}$ ) is the best choice for the output capacitor. An aluminum electrolytic ( $\geq 10 \mu\text{F}$ ) may be used if the ESR is in the stable range.

It should be noted that the ESR of a typical aluminum electrolytic will increase by as much as 50X as the temperature is reduced from 25°C down to -40°C, while a Tantalum will exhibit an ESR increase of about 2X over the same range. For this and other reasons, aluminum electrolytics should not be used in applications where low operating temperatures occur.

The lower stable ESR limit of 25 m $\Omega$  means that ceramic capacitors can not be used directly on the output of an LDO. A ceramic ( $\geq 2.2 \mu\text{F}$ ) can be used on the output if some external resistance is placed in series with it (1 $\Omega$  recommended). Dielectric types X7R or X5R must be used if the temperature range of the application varies more than  $\pm 25^\circ\text{C}$  from ambient to assure the amount of capacitance is sufficient.

### CERAMIC BYPASS CAPACITORS

Many designers place distributed ceramic capacitors whose value is in the range of 1000 pF to 0.1  $\mu\text{F}$  at the power input pins of the IC's across a circuit board. These can cause reduced phase margin or oscillations in LDO regulators.

The advent of multi-layer boards with dedicated power and ground planes has removed the trace inductance that (previously) provided the necessary "decoupling" to shield the output of the LDO from the effects of bypass capacitors.

These capacitors should be avoided if possible, and kept as far away from the LDO output as is practical.

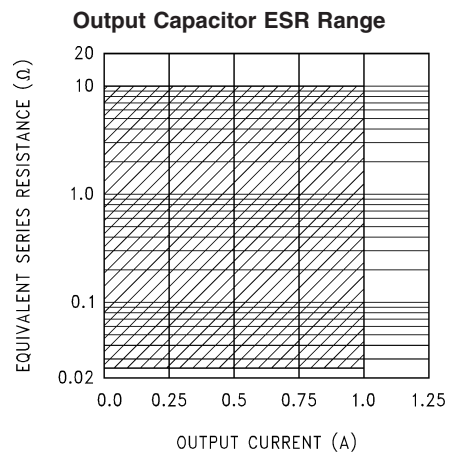

### MINIMUM LOAD

A minimum load current of 500  $\mu\text{A}$  is required for proper operation. The external resistor divider can provide the minimum load, with the resistor from the adjust pin to ground set to 2.4 k $\Omega$ .

### SETTING THE OUTPUT VOLTAGE

The output voltage of the LM2991 is set externally by a resistor divider using the following equation:

$$V_{\text{OUT}} = V_{\text{REF}} \times (1 + R_2/R_1) - (I_{\text{ADJ}} \times R_2)$$

where  $V_{\text{REF}} = -1.21\text{V}$ . The output voltage can be programmed within the range of -3V to -24V, typically an even greater range of -2V to -25V. The adjust pin current is about 60 nA, causing a slight error in the output voltage. However,

## Application Hints (Continued)

using resistors lower than 100 kΩ makes the adjust pin current negligible. For example, neglecting the adjust pin current, and setting R2 to 100 kΩ and V<sub>OUT</sub> to -5V, results in an output voltage error of only 0.16%.

### ON/OFF PIN

The LM2991 regulator can be turned off by applying a TTL or CMOS level high signal to the ON/OFF pin (see Adjustable Current Sink Application).

## Typical Applications

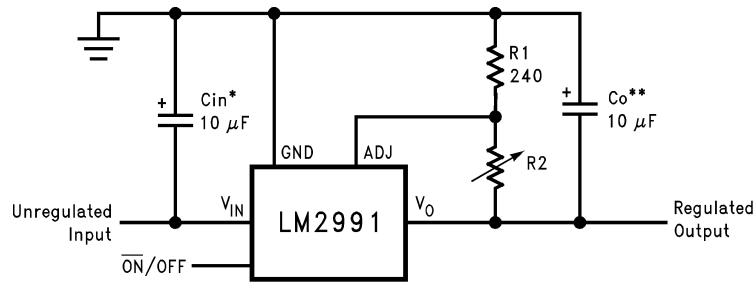

20158701

$$V_O = V_{Ref} (1 + R2/R1)$$

\*Required if the regulator is located further than 6 inches from the power supply filter capacitors. A 1 μF solid tantalum or a 10 μF aluminum electrolytic capacitor is recommended.

\*\*Required for stability. Must be at least a 10 μF aluminum electrolytic or a 1 μF solid tantalum to maintain stability. May be increased without bound to maintain regulation during transients. Locate the capacitor as close as possible to the regulator. The equivalent series resistance (ESR) is critical, and should be less than 10Ω over the same operating temperature range as the regulator.

### Fully Isolated Post-Switcher Regulator

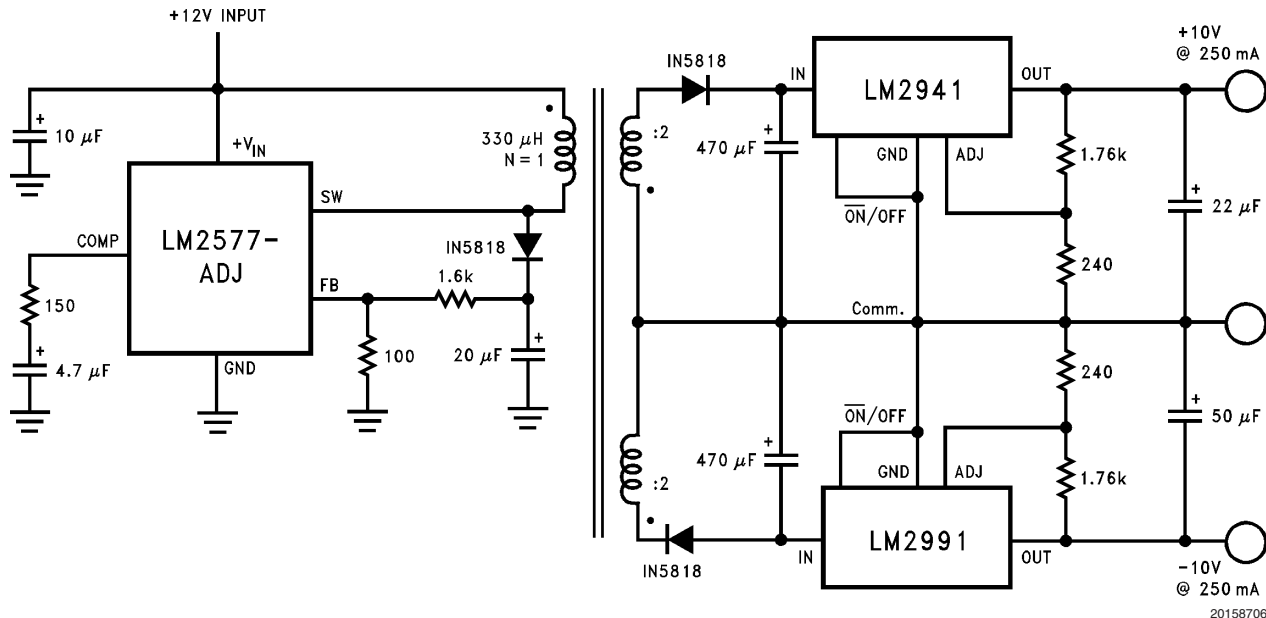

20158706

# Typical Applications (Continued)

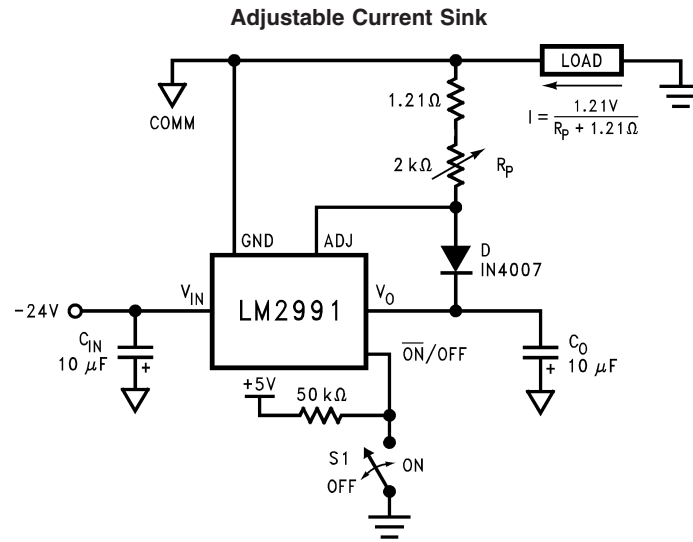

20158710

## Revision History

Released	Revision	Section	Originator	Changes
03/10/06	A	New Release, Corporate format	L. Lytle	1 MDS data sheet converted into one Corp. data sheet format. MNLM2991-X Rev 1A1 will be archived.

**Physical Dimensions** inches (millimeters) unless otherwise noted

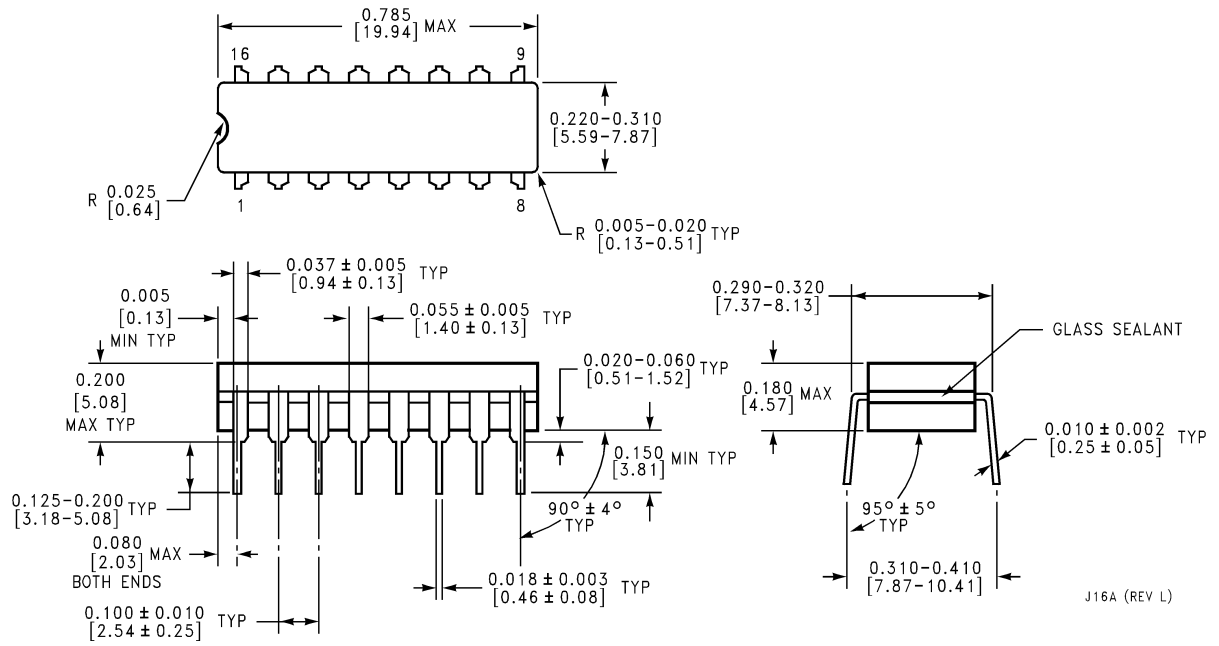

**16-Lead Ceramic Dual-in-Line Package  
NS Package Number J16A**

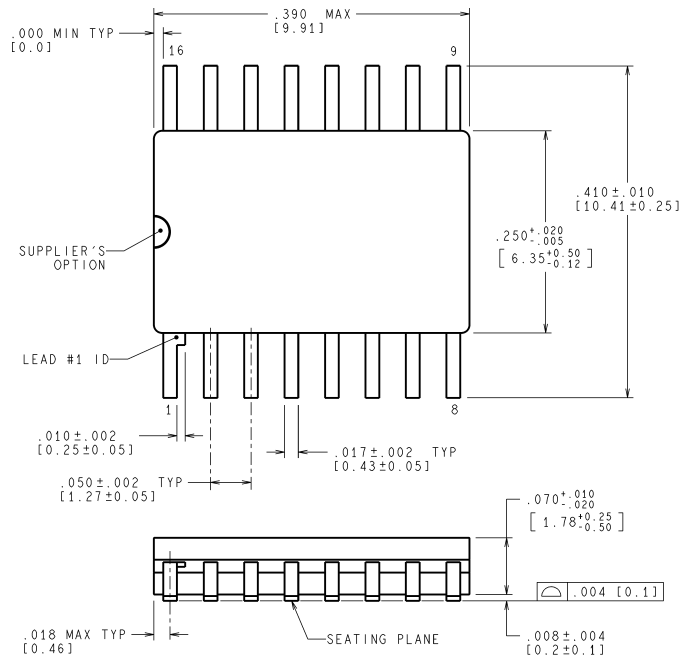

CONTROLLING DIMENSION IS INCH  
VALUES IN [ ] ARE MILLIMETERS

MIL-PRF-38535  
CONFIGURATION CONTROL

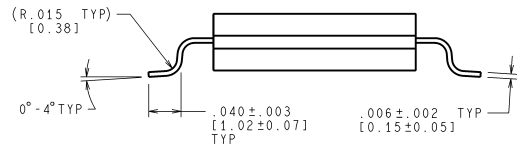

WG16A (Rev D)

**16-Lead Ceramic Surface-Mount Package  
NS Package Number WG16A**

## Notes

National does not assume any responsibility for use of any circuitry described, no circuit patent licenses are implied and National reserves the right at any time without notice to change said circuitry and specifications.

For the most current product information visit us at [www.national.com](http://www.national.com).

### LIFE SUPPORT POLICY

NATIONAL'S PRODUCTS ARE NOT AUTHORIZED FOR USE AS CRITICAL COMPONENTS IN LIFE SUPPORT DEVICES OR SYSTEMS WITHOUT THE EXPRESS WRITTEN APPROVAL OF THE PRESIDENT AND GENERAL COUNSEL OF NATIONAL SEMICONDUCTOR CORPORATION. As used herein:

1. Life support devices or systems are devices or systems which, (a) are intended for surgical implant into the body, or (b) support or sustain life, and whose failure to perform when properly used in accordance with instructions for use provided in the labeling, can be reasonably expected to result in a significant injury to the user.
2. A critical component is any component of a life support device or system whose failure to perform can be reasonably expected to cause the failure of the life support device or system, or to affect its safety or effectiveness.

### BANNED SUBSTANCE COMPLIANCE

National Semiconductor manufactures products and uses packing materials that meet the provisions of the Customer Products Stewardship Specification (CSP-9-111C2) and the Banned Substances and Materials of Interest Specification (CSP-9-111S2) and contain no "Banned Substances" as defined in CSP-9-111S2.

Leadfree products are RoHS compliant.



**National Semiconductor**  
Americas Customer  
Support Center  
Email: [new.feedback@nsc.com](mailto:new.feedback@nsc.com)  
Tel: 1-800-272-9959

**National Semiconductor**  
Europe Customer Support Center  
Fax: +49 (0) 180-530 85 86  
Email: [europe.support@nsc.com](mailto:europe.support@nsc.com)  
Deutsch Tel: +49 (0) 69 9508 6208  
English Tel: +44 (0) 870 24 0 2171  
Français Tel: +33 (0) 1 41 91 8790

**National Semiconductor**  
Asia Pacific Customer  
Support Center  
Email: [ap.support@nsc.com](mailto:ap.support@nsc.com)

**National Semiconductor**  
Japan Customer Support Center  
Fax: 81-3-5639-7507  
Email: [jpn.feedback@nsc.com](mailto:jpn.feedback@nsc.com)  
Tel: 81-3-5639-7560