

LM193A/LM193QML

Low Power Low Offset Voltage Dual Comparators

General Description

The LM193 series consists of two independent precision voltage comparators with an offset voltage specification as low as 2.0 mV max for two comparators which were designed specifically to operate from a single power supply over a wide range of voltages. Operation from split power supplies is also possible and the low power supply current drain is independent of the magnitude of the power supply voltage. These comparators also have a unique characteristic in that the input common-mode voltage range includes ground, even though operated from a single power supply voltage.

Application areas include limit comparators, simple analog to digital converters; pulse, squarewave and time delay generators; wide range VCO; MOS clock timers; multivibrators and high voltage digital logic gates. The LM193 series was designed to directly interface with TTL and CMOS. When operated from both plus and minus power supplies, the LM193 series will directly interface with MOS logic where their low power drain is a distinct advantage over standard comparators.

Advantages

- High precision comparators
- Reduced V_{OS} drift over temperature
- Eliminates need for dual supplies
- Allows sensing near ground
- Compatible with all forms of logic
- Power drain suitable for battery operation

Features

- Available with radiation guarantee
 - Total Ionizing Dose 100 krad(Si)
 - ELDRS Free 100 krad(Si)
- Wide supply
 - Voltage range: 2.0V_{DC} to 36V_{DC}
 - Single or dual supplies: ±1.0V to ±18V
- Very low supply current drain (0.4 mA) — independent of supply voltage
- Low input biasing current: 25 nA typ
- Low input offset current: ±5 nA typ
- Input common-mode voltage range includes ground
- Differential input voltage range equal to the power supply voltage
- Low output saturation voltage,; 250 mV at 4 mA typ
- Output voltage compatible with TTL, DTL, ECL, MOS and CMOS logic systems

Ordering Information

NS Part Number	SMD Part Number	NS Package Number	Package Description
LM193H/883		H08C	8LD T0-99 Metal Can
LM193J/883		J08A	8LD CERDIP
LM193AH/883	5962-9452602MGA	H08C	8LD T0-99 Metal Can
LM193AJ/883	5962-9452602MPA	J08A	8LD CERDIP
LM193AH-QMLV	5962-9452602VGA	H08C	8LD T0-99 Metal Can
LM193AJ-QMLV	5962-9452602VPA	J08A	8LD CERDIP
LM193AHRQMLV (Note 11)	5962R9452602VGA 100 krad(Si)	H08C	8LD T0-99 Metal Can
LM193AJRQMLV (Note 11)	5962R9452602VPA 100 krad(Si)	J08A	8LD CERDIP
LM193AHRQLQMLV (Note 12) ELDRS Free	5962R9452603VGA 100 krad(Si)	H08C	8LD T0-99 Metal Can
LM193AJRQLQMLV (Note 12) ELDRS Free	5962R9452603VPA 100 krad(Si)	J08A	8LD CERDIP

Schematic and Connection Diagrams

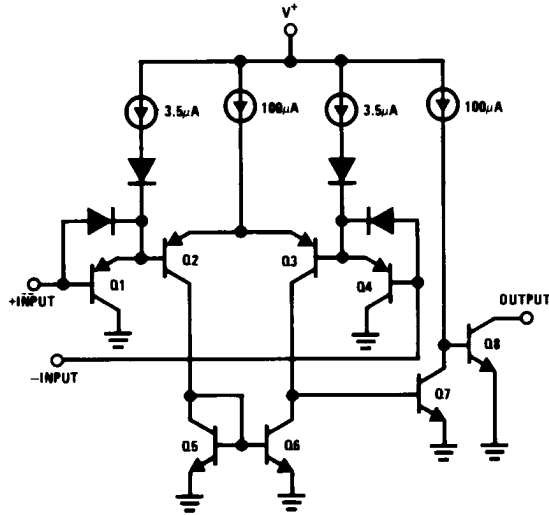

20139602

Metal Can Package

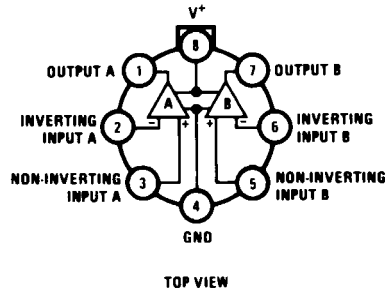

20139603

Dual-In-Line Package

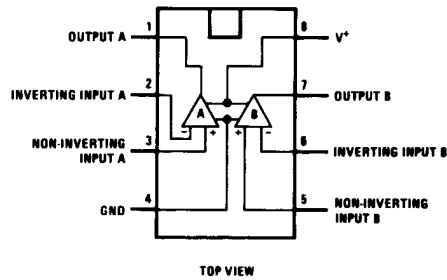

20139601

Absolute Maximum Ratings (Note 1)

Supply Voltage, V ⁺	36V _{DC} or ±18V _{DC}
Differential Input Voltage (Note 6)	36V
Input Voltage	-0.3V _{DC} to +36V _{DC}
Input Current (V _{IN} < -0.3V _{DC}) (Note 5)	50 mA
Maximum Junction Temperature	150°C
Power Dissipation (Note 2), (Note 3)	
Metal Can	660 mW
CERDIP	780 mW
Output Short-Circuit to Ground (Note 4)	Continuous
Operating Temperature Range	-55°C ≤ T _A ≤ +125°C
Storage Temperature Range	-65°C ≤ T _A ≤ +150°C
Thermal Resistance	
θ _{JA}	
Metal Can (Still Air)	174°C/W
Metal Can (500LF/Min Air flow)	99°C/W
CERDIP (Still Air)	146°C/W
CERDIP (500LF/Min Air flow)	85°C/W
θ _{JC}	
Metal Can	44°C/W
CERDIP	33°C/W
Lead Temperature (Soldering, 10 seconds)	260°C
ESD Tolerance (Note 7)	500V

Quality Conformance Inspection

Mil-Std-883, Method 5005 - Group A

Subgroup	Description	Temp°C
1	Static tests at	25
2	Static tests at	125
3	Static tests at	-55
4	Dynamic tests at	25
5	Dynamic tests at	125
6	Dynamic tests at	-55
7	Functional tests at	25
8A	Functional tests at	125
8B	Functional tests at	-55
9	Switching tests at	25
10	Switching tests at	125
11	Switching tests at	-55
12	Settling time at	25
13	Settling time at	125
14	Settling time at	-55

LM193 Electrical Characteristics

DC Parameters

The following conditions apply, unless otherwise specified. $+V = 5V$, $V_{CM} = 0V$

Symbol	Parameter	Conditions	Notes	Min	Max	Unit	Sub-groups
I_{CC}	Supply Current				1.0	mA	1, 2, 3
		$+V = 36V$			2.5	mA	1, 2, 3
I_{CEX}	Output Leakage Current	$+V = 30V$, $+V_I = 1V$, $V_O = 30V$, $-V_I = 0V$		-0.65	0.65	μA	1
				-1.0	1.0	μA	2, 3
I_{Sink}	Output Sink Current	$V_O = 1.5V$, $-V_I = 1V$, $+V_I = 0V$		6.0		mA	1
V_{Sat}	Output Saturation Voltage	$I_{Sink} = 4mA$, $-V_I = 1V$, $+V_I = 0V$			0.4	V	1
					0.7	V	2, 3
V_{IO}	Input Offset Voltage			-5.0	5.0	mV	1
				-9.0	9.0	mV	2, 3
			$+V = 30V$	-5.0	5.0	mV	1
				-9.0	9.0	mV	2, 3
			$+V = 30V$, $V_{CM} = 28.5V$	-5.0	5.0	mV	1
			$+V = 30V$, $V_{CM} = 28.0V$	-9.0	9.0	mV	2, 3
$\pm I_{IB}$	Input Bias Current			-100	-1.0	nA	1
				-300	-1.0	nA	2, 3
I_{IO}	Input offset Current	$R_S = 50\Omega$		-25	25	nA	1
				-100	100	nA	2, 3
V_{CM}	Common Mode Voltage	$+V = 30V$	(Note 8)		28.5	V	1
			(Note 8)		28	V	2, 3
PSRR	Power Supply Rejection Ratio	$+V = 5V$ to $30V$, $R_S = 50\Omega$		60		dB	1
CMRR	Common Mode Rejection Ratio	$+V = 30V$, $R_S = 50\Omega$ $V_{CM} = 0V$ to $28.5V$,		60		dB	1
V_{Diff}	Differential Input Voltage	$+V = 30V$, $+V_I = 36V$, $-V_I = 0V$	(Note 10)		500	nA	1, 2, 3
		$+V = 30V$, $+V_I = 0V$, $-V_I = +36V$	(Note 10)		500	nA	1, 2, 3
A_{VS}	Voltage Gain	$+V = 15V$, $R_{PullUp} = 15K\Omega$ $1V \leq V_O \leq 11V$,	(Note 9)	50		V/mV	4

AC Parameters

The following conditions apply, unless otherwise specified. $+V = 5V$

Symbol	Parameter	Conditions	Notes	Min	Max	Unit	Sub-groups
t_{RLH}	Response Time	$V_{OD} = 5mV$			5.0	μS	9
		$V_{OD} = 50mV$			0.8	μS	9
t_{RHL}	Response Time	$V_{OD} = 5mV$			2.5	μS	9
		$V_{OD} = 50mV$			0.8	μS	9

LM193A Electrical Characteristics

DC Parameters

The following conditions apply, unless otherwise specified. $+V = 5V$, $V_{CM} = 0V$

Symbol	Parameter	Conditions	Notes	Min	Max	Unit	Sub-groups
I_{CC}	Supply Current	$R_L = \text{Infinity}$			1.0	mA	1, 2, 3
		$+V = 36V$, $R_L = \text{Infinity}$			2.5	mA	1, 2, 3
I_{CEX}	Output Leakage Current	$+V = 30V$, $+V_I = 1V$, $V_O = 30$, $-V_I = 0$		-0.65	0.65	μA	1
				-1.0	1.0	μA	2, 3
I_{Sink}	Output Sink Current	$V_O = 1.5V$, $-V_I = 1V$, $+V_I = 0V$		6.0		mA	1
				4.0		mA	2, 3
V_{Sat}	Output Saturation Voltage	$I_{Sink} = 4mA$, $-V_I = 1V$, $+V_I = 0V$			0.4	V	1
					0.7	V	2, 3
V_{IO}	Input Offset Voltage			-2.0	2.0	mV	1
				-4.0	4.0	mV	2, 3
		$+V = 30V$		-2.0	2.0	mV	1
		$+V = 30V$, $V_{CM} = 28.5V$		-2.0	2.0	mV	1
		$+V = 30V$, $V_{CM} = 28.0V$		-4.0	4.0	mV	2, 3
$\pm I_{IB}$	Input Bias Current	$V_O = 1.5V$		-100	-1.0	nA	1
				-300	-1.0	nA	2, 3
I_{IO}	Input offset Current	$R_S = 50\Omega$, $V_O = 1.5V$		-25	25	nA	1
				-100	100	nA	2, 3
V_{CM}	Common Mode Voltage	$+V = 30V$	(Note 8)		28.5	V	1
			(Note 8)		28	V	2, 3
PSRR	Power Supply Rejection Ratio	$+V = 5V$ to $30V$, $R_S = 50\Omega$		60		dB	1
CMRR	Common Mode Rejection Ratio	$+V = 30V$, $R_S = 50\Omega$ $V_{CM} = 0V$ to $28.5V$,		60		dB	1
V_{Diff}	Differential Input Voltage	$+V = 30V$, $+V_I = 36V$, $-V_I = 0V$	(Note 10)		500	nA	1, 2, 3
		$+V = 30V$, $+V_I = 0V$, $-V_I = +36V$	(Note 10)		500	nA	1, 2, 3
A_{VS}	Voltage Gain	$+V = 15V$, $R_{PULLUP} = 15K\Omega$ $1V \leq V_O \leq 11V$,	(Note 9)	50		V/mV	4
			(Note 9)	25		V/mV	5, 6

AC Parameters

The following conditions apply, unless otherwise specified. $+V = 5V$, $V_{CM} = 0V$

Symbol	Parameter	Conditions	Notes	Min	Max	Unit	Sub-groups
t_{RLH}	Response Time	$V_{OD} = 5mV$			5.0	μS	9
		$V_{OD} = 50mV$			0.8	μS	9
t_{RHL}	Response Time	$V_{OD} = 5mV$			2.5	μS	9
		$V_{OD} = 50mV$			0.8	μS	9

DC Drift Parameters

The following conditions apply, unless otherwise specified. $+V = 5V$, $V_{CM} = 0V$

Delta calculations performed on QMLV devices at Group B, Subgroup 5 only

Symbol	Parameter	Conditions	Notes	Min	Max	Unit	Sub-groups
V_{IO}	Input Offset Voltage	$+V = 30V$		-1.0	1.0	mV	1
$\pm I_{IB}$	Input Bias Current			-15	15	nA	1

LM193A - 100K Radiation Electrical Characteristics

DC Parameters

The following conditions apply, unless otherwise specified. +V = 5V, $V_{CM} = 0V$

Symbol	Parameter	Conditions	Notes	Min	Max	Unit	Sub-groups
I_{CC}	Supply Current	$R_L = \text{Infinity}$			1.0	mA	1, 2, 3
		+V = 36V, $R_L = \text{Infinity}$			2.5	mA	1, 2, 3
I_{CEX}	Output Leakage Current	+V = 30V, $+V_I = 1V$, $V_O = 30$, $-V_I = 0$		-0.65	0.65	μA	1
				-1.0	1.0	μA	2, 3
I_{Sink}	Output Sink Current	$V_O = 1.5V$, $-V_I = 1V$, $+V_I = 0V$		6.0		mA	1
				4.0		mA	2, 3
V_{Sat}	Output Saturation Voltage	$I_{Sink} = 4mA$, $-V_I = 1V$, $+V_I = 0V$			0.4	V	1
					0.7	V	2, 3
V_{IO}	Input Offset Voltage			-2.0	2.0	mV	1
				-4.0	4.0	mV	2, 3
		+V = 30V		-2.0	2.0	mV	1
				-4.0	4.0	mV	2, 3
		+V = 30V, $V_{CM} = 28.5V$		-2.0	2.0	mV	1
	+V = 30V, $V_{CM} = 28.0V$		-4.0	4.0	mV	2, 3	
$\pm I_{IB}$	Input Bias Current	$V_O = 1.5V$		-100	-1.0	nA	1
				-300	-1.0	nA	2, 3
I_{IO}	Input offset Current	$R_S = 50\Omega$, $V_O = 1.5V$		-25	25	nA	1
				-100	100	nA	2, 3
V_{CM}	Common Mode Voltage	+V = 30V	(Note 8)		28.5	V	1
			(Note 8)		28	V	2, 3
PSRR	Power Supply Rejection Ratio	+V = 5V to 30V, $R_S = 50\Omega$		60		dB	1
CMRR	Common Mode Rejection Ratio	+V = 30V, $R_S = 50\Omega$ $V_{CM} = 0V$ to 28.5V,		60		dB	1
V_{Diff}	Differential Input Voltage	+V = 30V, $+V_I = 36V$, $-V_I = 0V$	(Note 10)		500	nA	1, 2, 3
		+V = 30V, $+V_I = 0V$, $-V_I = +36V$	(Note 10)		500	nA	1, 2, 3
A_{VS}	Voltage Gain	+V = 15V, $R_{PullUp} = 15K\Omega$	(Note 9)	50		V/mV	4
		$1V \leq V_O \leq 11V$,	(Note 9)	25		V/mV	5, 6

AC Parameters

The following conditions apply, unless otherwise specified. +V = 5V, $V_{CM} = 0V$

Symbol	Parameter	Conditions	Notes	Min	Max	Unit	Sub-groups
t_{RLH}	Response Time	$V_{OD} = 5mV$			5.0	μS	9
		$V_{OD} = 50mV$			0.8	μS	9
t_{RHL}	Response Time	$V_{OD} = 5mV$			2.5	μS	9
		$V_{OD} = 50mV$			0.8	μS	9

LM193A - 100K Radiation Electrical Characteristics (Continued)

DC Drift Parameters

The following conditions apply, unless otherwise specified. $+V = 5V$, $V_{CM} = 0V$

Delta calculations performed on QMLV devices at Group B, Subgroup 5 only

Symbol	Parameter	Conditions	Notes	Min	Max	Unit	Sub-groups
V_{IO}	Input Offset Voltage	$+V = 30V$		-1.0	1.0	mV	1
$\pm I_{IB}$	Input Bias Current			-15	15	nA	1

AC Parameters - Post Radiation Limits @ +25°C

The following conditions apply, unless otherwise specified. $+V = 5V$, $V_{CM} = 0V$

Symbol	Parameter	Conditions	Notes	Min	Max	Unit	Sub-groups
t_{RLH}	Response Time	$V_{OD} = 50mV$			1.0	μS	9

Note 1: Absolute Maximum Ratings indicate limits beyond which damage to the device may occur. Operating Ratings indicate conditions for which the device is functional, but do not guarantee specific performance limits. For guaranteed specifications and test conditions, see the Electrical Characteristics. The guaranteed specifications apply only for the test conditions listed. Some performance characteristics may degrade when the device is not operated under the listed test conditions.

Note 2: The maximum power dissipation must be derated at elevated temperatures and is dictated by T_{Jmax} (maximum junction temperature), θ_{JA} (package junction to ambient thermal resistance), and T_A (ambient temperature). The maximum allowable power dissipation at any temperature is $P_{Dmax} = (T_{Jmax} - T_A) / \theta_{JA}$ or the number given in the Absolute Maximum Ratings, whichever is lower.

Note 3: The LM193A must be derated based on a 150°C, T_{Jmax} . The low bias dissipation and the ON-OFF characteristic of the outputs keep the chip dissipation very small ($P_D \leq 100mW$), provided the output transistors are allowed to saturate.

Note 4: Short circuits from the output to V^+ can cause excessive heating and eventual destruction. When considering short circuits to ground, the maximum output current is approximately 20 mA independent of the magnitude of V^+ .

Note 5: This input current will only exist when the voltage at any of the input leads is driven negative. It is due to the collector-base junction of the input PNP transistors becoming forward biased and thereby acting as input diode clamps. In addition to this diode action, there is also lateral NPN parasitic transistor action on the IC chip. This transistor action can cause the output voltages of the comparators to go to the V^+ voltage level (or to ground for a large overdrive) for the time duration that an input is driven negative. This is not destructive and normal output states will re-establish when the input voltage, which was negative, again returns to a value greater than $-0.3V_{DC}$.

Note 6: Positive excursions of input voltage may exceed the power supply level. As long as the other voltage remains within the common-mode range, the comparator will provide a proper output state. The low input voltage state must not be less than $-0.3V$ (or 0.3V below the magnitude of the negative power supply, if used).

Note 7: Human body model, 1.5K Ω in series with 100pF.

Note 8: Parameter guaranteed by the V_{IO} tests.

Note 9: Datalog reading in $K = V/mV$.

Note 10: The value for V_{Diff} is not datalogged during Read and Record.

Note 11: Pre and post irradiation limits are identical to those listed under AC and DC electrical characteristics except as listed in the Post Radiation Limits Table. These parts may be dose rate sensitive in a space environment and demonstrate enhanced low dose rate effect. Radiation end point limits for the noted parameters are guaranteed only for the conditions as specified in MIL-STD-883, Method 1019

Note 12: Low dose rate testing has been performed on a wafer-by-wafer basis, per test method 1019 condition D of MIL-STD-883, with no enhanced low dose rate sensitivity (ELDRS) effect.

Typical Performance Characteristics

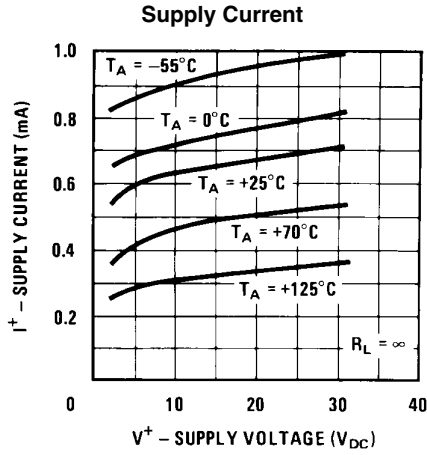

20139625

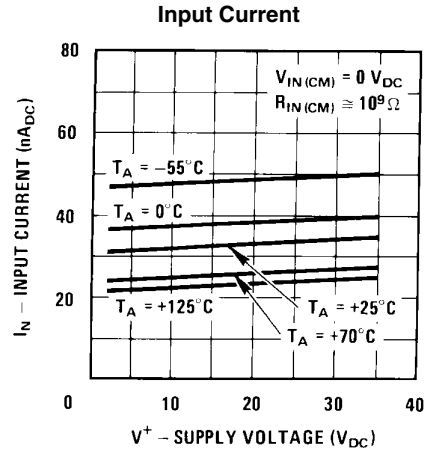

20139626

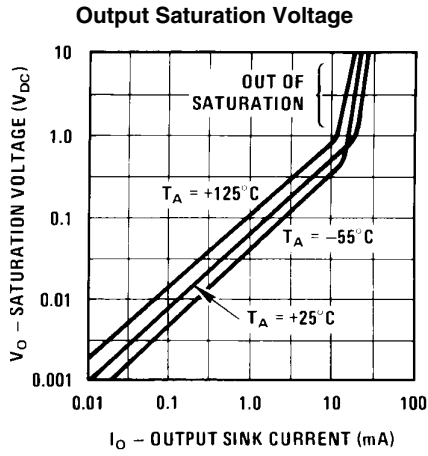

20139627

Response Time for Various Input Overdrives—Negative Transition

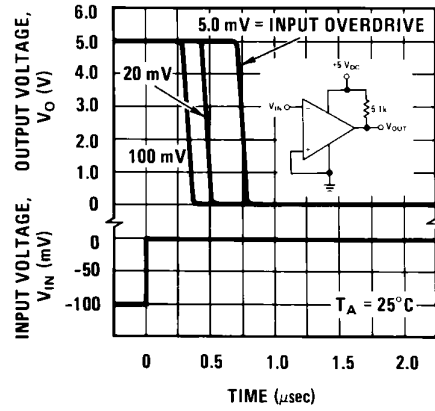

20139628

Response Time for Various Input Overdrives—Positive Transition

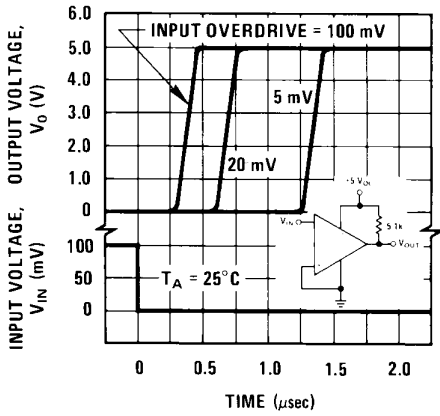

20139629

Application Hints

The LM193 series are high gain, wide bandwidth devices which, like most comparators, can easily oscillate if the output lead is inadvertently allowed to capacitively couple to the inputs via stray capacitance. This shows up only during the output voltage transition intervals as the comparators change states. Power supply bypassing is not required to solve this problem. Standard PC board layout is helpful as it reduces stray input-output coupling. Reducing the input resistors to $< 10\text{ K}\Omega$ reduces the feedback signal levels and finally, adding even a small amount (1.0 to 10 mV) of positive feedback (hysteresis) causes such a rapid transition that oscillations due to stray feedback are not possible. Simply socketing the IC and attaching resistors to the pins will cause input-output oscillations during the small transition intervals unless hysteresis is used. If the input signal is a pulse waveform, with relatively fast rise and fall times, hysteresis is not required.

All input pins of any unused comparators should be tied to the negative supply.

The bias network of the LM193 series establishes a drain current which is independent of the magnitude of the power supply voltage over the range of from 2.0 V_{DC} to 30 V_{DC} .

It is usually unnecessary to use a bypass capacitor across the power supply line.

The differential input voltage may be larger than V^+ without damaging the device (Note 6). Protection should be provided to prevent the input voltages from going negative more than $-0.3\text{ V}_{\text{DC}}$ (at 25°C). An input clamp diode can be used as shown in the applications section.

The output of the LM193 series is the uncommitted collector of a grounded-emitter NPN output transistor. Many collectors can be tied together to provide an output OR'ing function. An output pull-up resistor can be connected to any available power supply voltage within the permitted supply voltage range and there is no restriction on this voltage due to the magnitude of the voltage which is applied to the V^+ terminal of the LM193 package. The output can also be used as a simple SPST switch to ground (when a pull-up resistor is not used). The amount of current which the output device can sink is limited by the drive available (which is independent of V^+) and the β of this device. When the maximum current limit is reached (approximately 16mA), the output transistor will come out of saturation and the output voltage will rise very rapidly. The output saturation voltage is limited by the approximately $60\Omega\text{ }r_{\text{SAT}}$ of the output transistor. The low offset voltage of the output transistor (1.0mV) allows the output to clamp essentially to ground level for small load currents.

Typical Applications

($V^+=5.0\text{ V}_{\text{DC}}$)

Basic Comparator

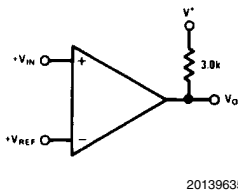

20139635

Driving CMOS

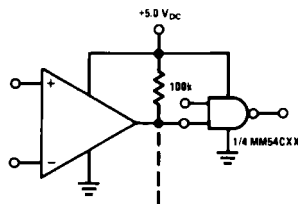

20139636

Driving TTL

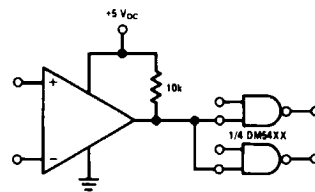

20139637

Squarewave Oscillator

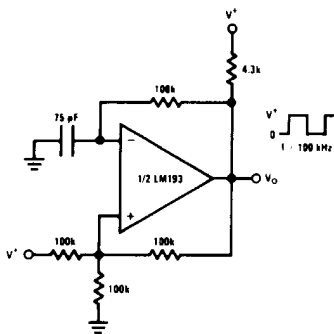

20139638

Pulse Generator

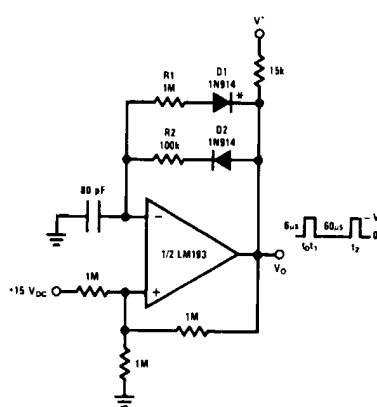

20139639

* For large ratios of $R1/R2$, $D1$ can be omitted.

Crystal Controlled Oscillator

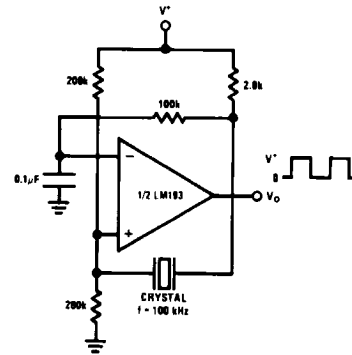

20139640

Two-Decade High Frequency VCO

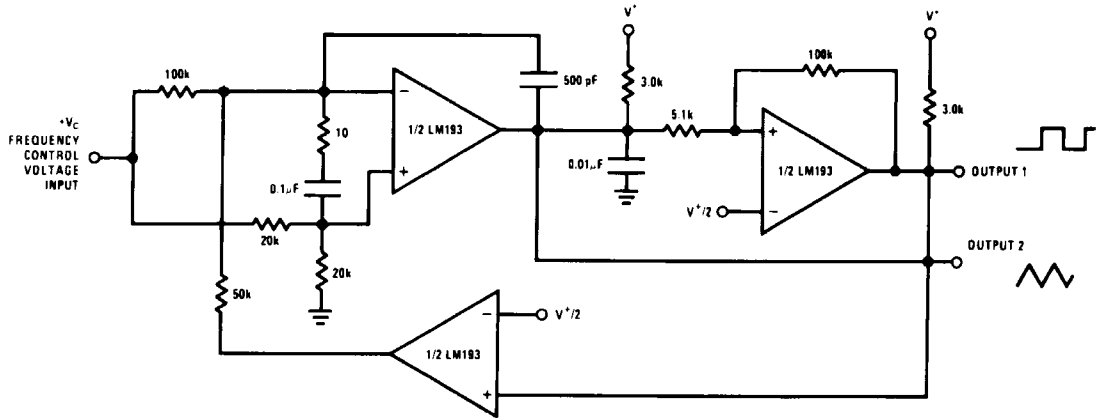

20139641

$V^* = +30 V_{DC}$
 $+250 mV_{DC} \leq V_C \leq +50 V_{DC}$
 $700Hz \leq f_o \leq 100kHz$

Basic Comparator

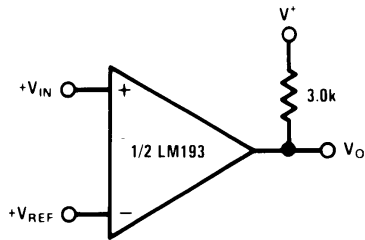

20139606

Non-Inverting Comparator with Hysteresis

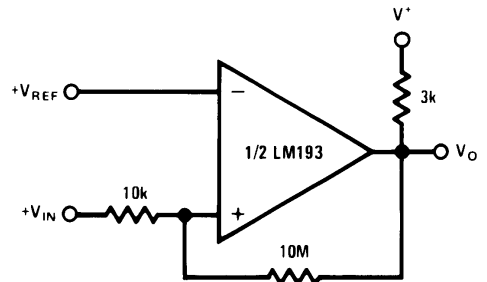

20139609

Inverting Comparator with Hysteresis

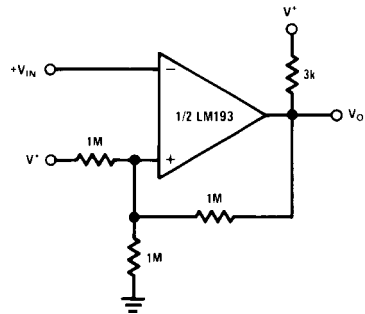

20139610

Output Strobing

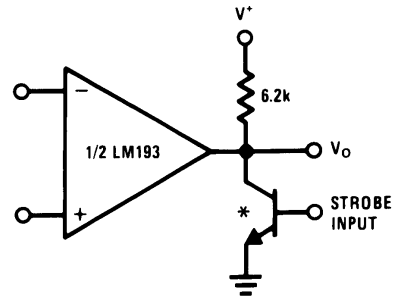

* OR LOGIC GATE
 WITHOUT PULL-UP RESISTOR

20139611

AND Gate

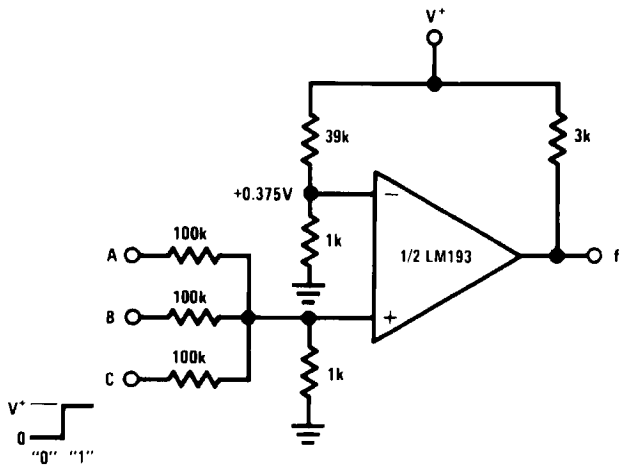

20139612

OR Gate

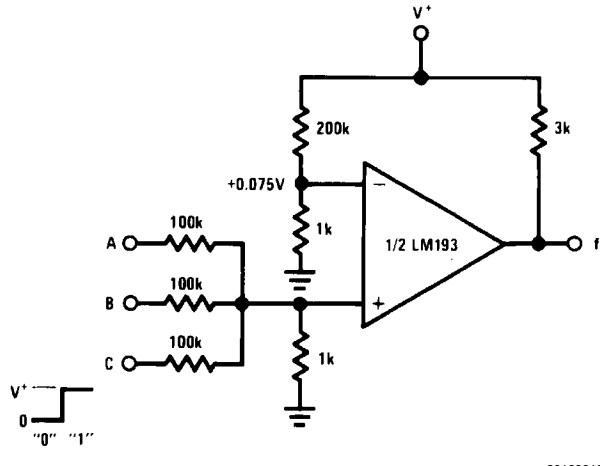

20139613

Large Fan-in AND Gate

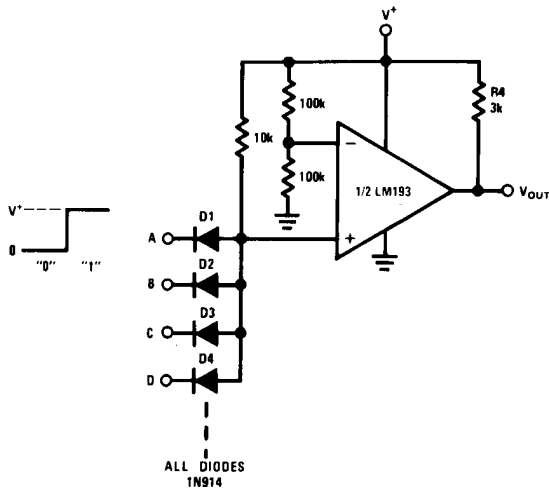

20139614

Limit Comparator

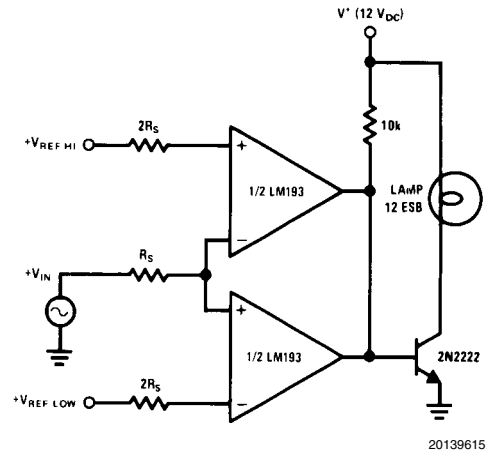

20139615

Comparing Input Voltages of Opposite Polarity

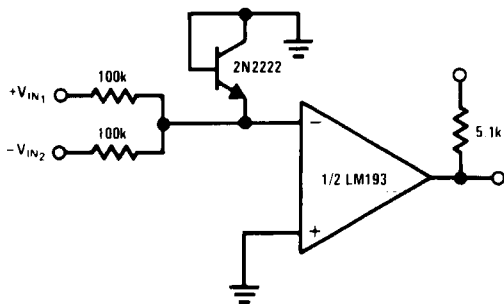

20139616

ORing the Outputs

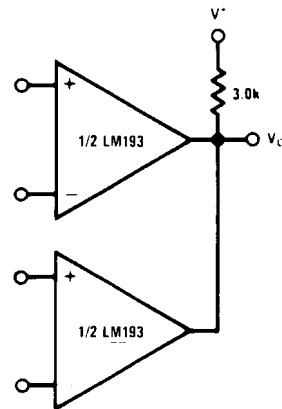

20139617

Zero Crossing Detector (Single Power Supply)

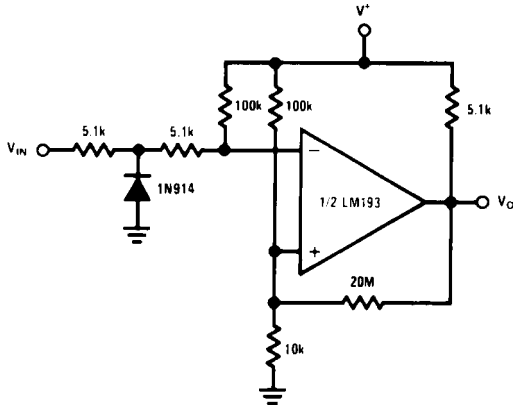

20139621

One-Shot Multivibrator

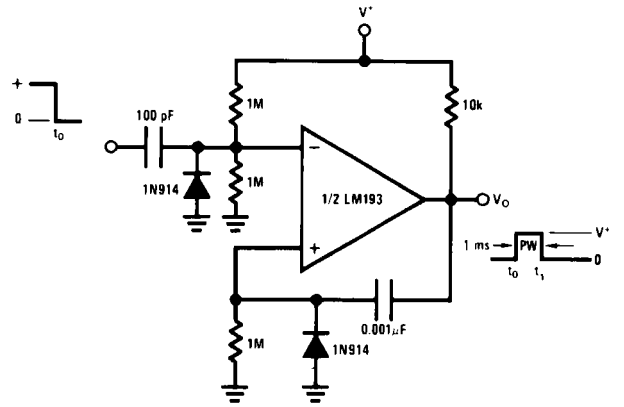

20139622

Bi-Stable Multivibrator

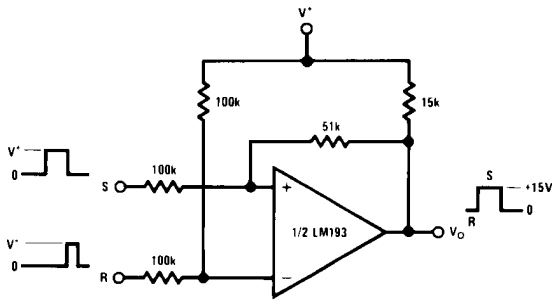

20139624

One-Shot Multivibrator with Input Lock Out

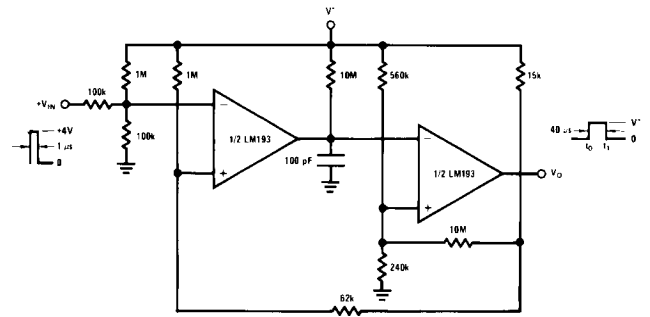

20139623

Zero Crossing Detector

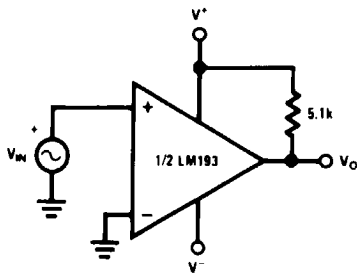

20139643

Comparator With a Negative Reference

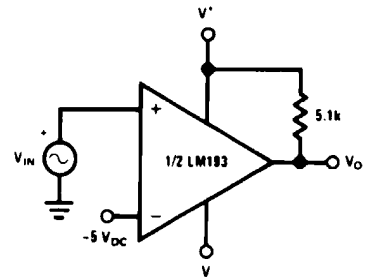

20139644

Time Delay Generator

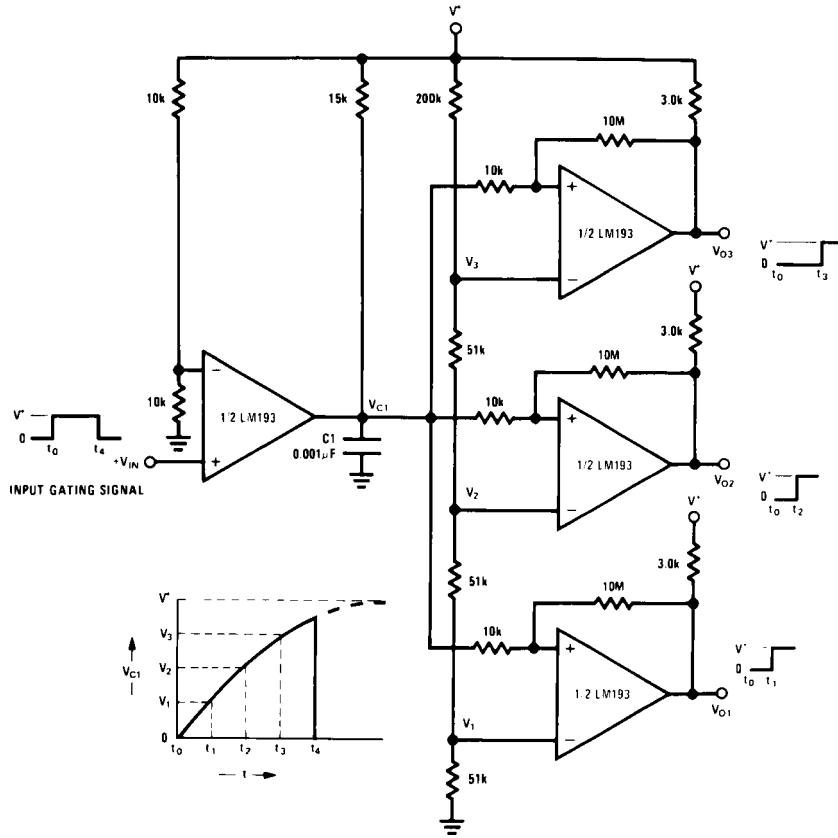

20139607

Split-Supply Applications

($V^+=+15 V_{DC}$ and $V^-=-15 V_{DC}$)

MOS Clock Driver

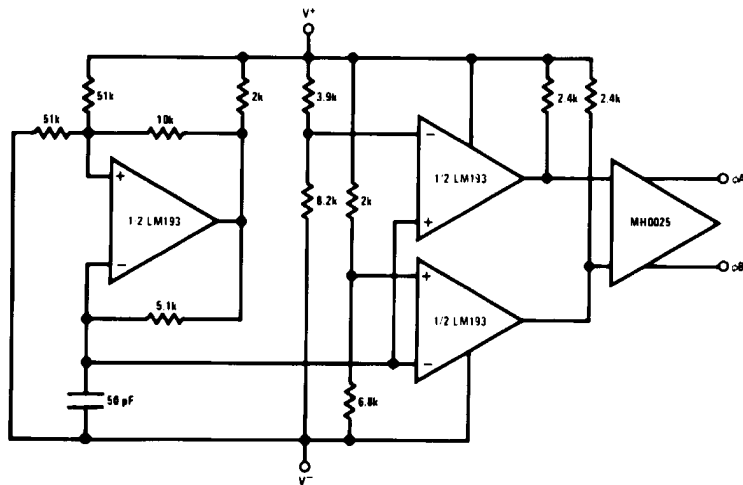

20139642

Revision History

Date Released	Revision	Section	Originator	Changes
05/09/05	A	New Release. Corporate format	L. Lytle	2 MDS datasheets converted into one Corp. datasheet format. MNL193A-X Rev 1B3 & MNL193-X Rev 0E1. The Iout Vsat condition for LM193 was changed to Isink for consistency with the LM193A and JAN electrical conditions. Also, redundant parameters were removed from conditions that were defined at beginning of the table. MDS data sheets will be archived.
05/07/07	B	Features, Ordering Information, LM193A Electricals	Larry McGee	Added Radiation Electrical information for LM193A Device. Revision A will be archived.
10/29/07	C	Features, Ordering Information, Notes	Larry McGee	Added reference to New ELDS NSID and SMD Device 03, ELDRS Note 12. Revision B will be archived.

Physical Dimensions inches (millimeters) unless otherwise noted

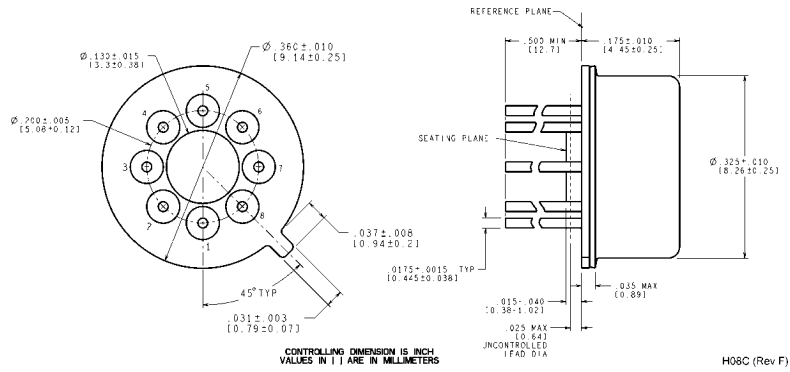

Metal Can Package (H)
NS Package Number H08C

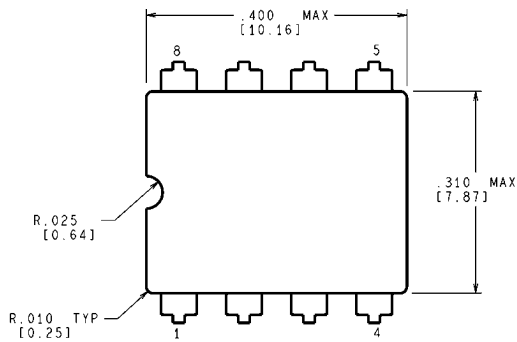

CONTROLLING DIMENSION IS INCH
VALUES IN [] ARE MILLIMETERS

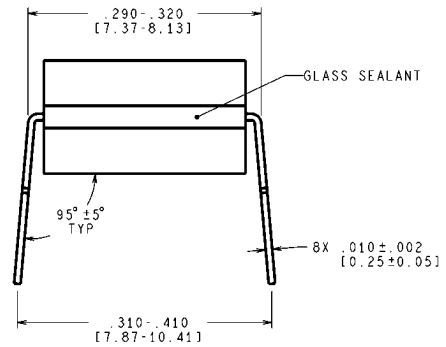
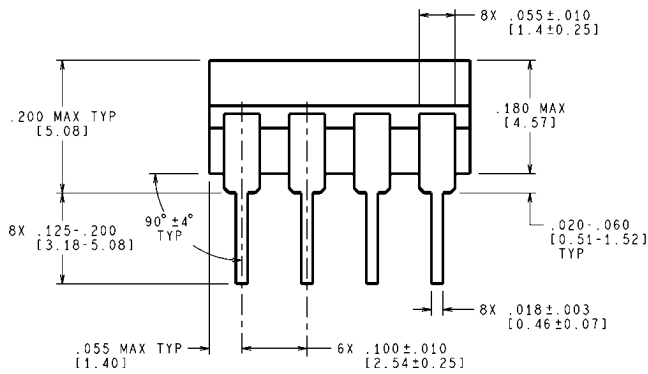

Ceramic Dual-In-Line Package
NS Package Number J08A

J08A (Rev M)

Notes

THE CONTENTS OF THIS DOCUMENT ARE PROVIDED IN CONNECTION WITH NATIONAL SEMICONDUCTOR CORPORATION ("NATIONAL") PRODUCTS. NATIONAL MAKES NO REPRESENTATIONS OR WARRANTIES WITH RESPECT TO THE ACCURACY OR COMPLETENESS OF THE CONTENTS OF THIS PUBLICATION AND RESERVES THE RIGHT TO MAKE CHANGES TO SPECIFICATIONS AND PRODUCT DESCRIPTIONS AT ANY TIME WITHOUT NOTICE. NO LICENSE, WHETHER EXPRESS, IMPLIED, ARISING BY ESTOPPEL OR OTHERWISE, TO ANY INTELLECTUAL PROPERTY RIGHTS IS GRANTED BY THIS DOCUMENT.

TESTING AND OTHER QUALITY CONTROLS ARE USED TO THE EXTENT NATIONAL DEEMS NECESSARY TO SUPPORT NATIONAL'S PRODUCT WARRANTY. EXCEPT WHERE MANDATED BY GOVERNMENT REQUIREMENTS, TESTING OF ALL PARAMETERS OF EACH PRODUCT IS NOT NECESSARILY PERFORMED. NATIONAL ASSUMES NO LIABILITY FOR APPLICATIONS ASSISTANCE OR BUYER PRODUCT DESIGN. BUYERS ARE RESPONSIBLE FOR THEIR PRODUCTS AND APPLICATIONS USING NATIONAL COMPONENTS. PRIOR TO USING OR DISTRIBUTING ANY PRODUCTS THAT INCLUDE NATIONAL COMPONENTS, BUYERS SHOULD PROVIDE ADEQUATE DESIGN, TESTING AND OPERATING SAFEGUARDS.

EXCEPT AS PROVIDED IN NATIONAL'S TERMS AND CONDITIONS OF SALE FOR SUCH PRODUCTS, NATIONAL ASSUMES NO LIABILITY WHATSOEVER, AND NATIONAL DISCLAIMS ANY EXPRESS OR IMPLIED WARRANTY RELATING TO THE SALE AND/OR USE OF NATIONAL PRODUCTS INCLUDING LIABILITY OR WARRANTIES RELATING TO FITNESS FOR A PARTICULAR PURPOSE, MERCHANTABILITY, OR INFRINGEMENT OF ANY PATENT, COPYRIGHT OR OTHER INTELLECTUAL PROPERTY RIGHT.

LIFE SUPPORT POLICY

NATIONAL'S PRODUCTS ARE NOT AUTHORIZED FOR USE AS CRITICAL COMPONENTS IN LIFE SUPPORT DEVICES OR SYSTEMS WITHOUT THE EXPRESS PRIOR WRITTEN APPROVAL OF THE CHIEF EXECUTIVE OFFICER AND GENERAL COUNSEL OF NATIONAL SEMICONDUCTOR CORPORATION. As used herein:

Life support devices or systems are devices which (a) are intended for surgical implant into the body, or (b) support or sustain life and whose failure to perform when properly used in accordance with instructions for use provided in the labeling can be reasonably expected to result in a significant injury to the user. A critical component is any component in a life support device or system whose failure to perform can be reasonably expected to cause the failure of the life support device or system or to affect its safety or effectiveness.

National Semiconductor and the National Semiconductor logo are registered trademarks of National Semiconductor Corporation. All other brand or product names may be trademarks or registered trademarks of their respective holders.

Copyright© 2007 National Semiconductor Corporation

For the most current product information visit us at www.national.com



**National Semiconductor
Americas Customer
Support Center**
Email:
new.feedback@nsc.com
Tel: 1-800-272-9959

**National Semiconductor Europe
Customer Support Center**
Fax: +49 (0) 180-530-85-86
Email: europe.support@nsc.com
Deutsch Tel: +49 (0) 69 9508 6208
English Tel: +49 (0) 870 24 0 2171
Français Tel: +33 (0) 1 41 91 8790

**National Semiconductor Asia
Pacific Customer Support Center**
Email: ap.support@nsc.com

**National Semiconductor Japan
Customer Support Center**
Fax: 81-3-5639-7507
Email: jpn.feedback@nsc.com
Tel: 81-3-5639-7560