

2N2880

**5 Amp, 80V,
 Planar, NPN
 Power Transistors
 JAN,JTX,JANTXV,JANS**

APPLICATIONS:

- Fast Switching
- High Frequency Switching and Amplifying

FEATURES:

- High Reliability
- Greater Gain Stability

DESCRIPTION:

These power transistors are produced by PPC's DOUBLE DIFFUSED PLANAR process. This technology produces high voltage devices with excellent switching speeds, frequency response, gain linearity, saturation voltages, high current gain, and safe operating areas. They are intended for use in Commercial, Industrial, and Military power switching, amplifier, and regulator applications.

Ultrasonically bonded leads and controlled die mount techniques are utilized to further increase the SOA capability and inherent reliability of these devices. The temperature range to 200°C permits reliable operation in high ambients, and the hermetically sealed package insures maximum reliability and long life.

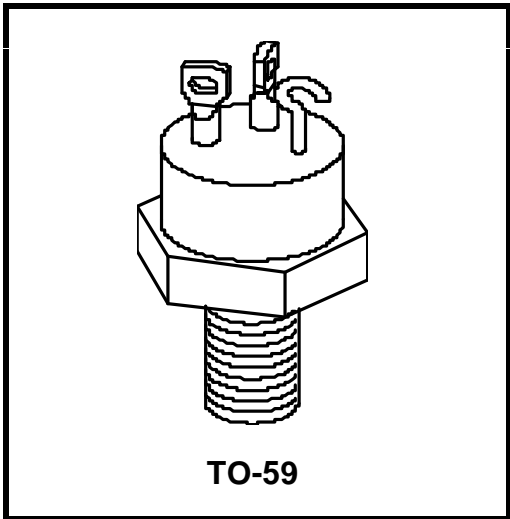

ABSOLUTE MAXIMUM RATINGS

SYMBOL	CHARACTERISTIC	VALUE	UNITS
V _{CBO} *	Collector-Base Voltage	110	V
V _{CEO} *	Collector-Emitter Voltage	80	V
V _{EBO} *	Emitter-Base Voltage	8	V
I _C *	Continuous Collector Current	5	A
I _B *	Continuous Base Current	0.5	A
T _{STG} *	Storage Temperature	-65 to 200	°C
T _J *	Operating Junction Temperature	-65 to 200	°C
*	Lead Temperature 1/16" From Case for 10 Sec.	230	°C
P _T *	Power Dissipation T _A = 25°C T _C = 100°C	2 30	W W
θ _{JC}	Thermal Resistance Junction to Case	3.33	°C/W

* Indicates MIL-S-19500/315

ELECTRICAL CHARACTERISTICS
(25°C Case Temperature Unless Otherwise Noted)

SYMBOL	CHARACTERISTIC	TEST CONDITIONS	VALUE		Units
			Min.	Max.	
BV_{CBO}^*	Collector-Base Voltage	$I_C = 10 \mu\text{A}$, Cond. D	110	----	Vdc
BV_{CEO}^*	Collector-Emitter Voltage (Note 1)	$I_C = 0.1 \text{ A}$, Cond. D	80	----	Vdc
BV_{EBO}^*	Emitter-Base Voltage	$I_E = 10 \mu\text{A}$, Cond. D	8	----	Vdc
I_{CEO}^*	Collector-Emitter Cutoff Current	$V_{CE} = 60 \text{ Vdc}$, Cond. D	----	20	μA
I_{CEX}^*	Collector-Emitter Cutoff Current	$V_{CE} = 110 \text{ Vdc}$, $V_{EB} = 0.5 \text{ Vdc}$, Cond. A $V_{CE} = 80 \text{ Vdc}$, $V_{EB} = 0.5 \text{ Vdc}$, Cond. A, $T_A = 150^\circ\text{C}$	----	1.0 50	μA μA
I_{CBO}^*	Collector-Base Cutoff Current	$V_{CB} = 80 \text{ Vdc}$, Cond. D $V_{CB} = 60 \text{ Vdc}$, Cond. D, $T_A = -150^\circ\text{C}$	----	0.2 10	μA ----
I_{EBO}^*	Emitter-Base Cutoff Current	$V_{EB} = 6 \text{ Vdc}$, Cond. D	----	0.2	μA
hFE^*	DC Current Gain (Note 1)	$I_C = 50 \text{ mA}$, $V_{CE} = 5 \text{ Vdc}$ $I_C = 1 \text{ A}$, $V_{CE} = 5 \text{ Vdc}$ $I_C = 5 \text{ A}$, $V_{CE} = 5 \text{ Vdc}$ $I_C = 1 \text{ A}$, $V_{CE} = 5 \text{ Vdc}$, $T_A = -55^\circ\text{C}$	40 40 15 15	120 120 ----	----
hFE^*	AC Current Gain	$I_C = 50 \text{ mA}$, $V_{CE} = 5 \text{ Vdc}$, $f = \text{ KHz}$	40	120	----
$V_{CE(sat)}^*$	Collector Saturation Voltage (Note 1)	$I_C = 1 \text{ A}$, $I_B = 0.1 \text{ A}$ $I_C = 5 \text{ A}$, $I_B = 0.5 \text{ A}$	----	0.25 1.5	Vdc Vdc
$V_{BE(sat)}^*$	Base Saturation Voltage (Note 1)	$I_C = 1 \text{ A}$, $I_B = 0.1 \text{ A}$	----	1.2	Vdc
$V_{BE(on)}^*$	Base On-Voltage (Note 1)	$I_C = 1 \text{ A}$, $V_{CE} = 2 \text{ Vdc}$	----	1.2	Vdc
f_T^*	Gain-Bandwidth Product	$I_C = 1 \text{ A}$, $V_{CE} = 10 \text{ Vdc}$, $f = 10 \text{ MHz}$	30	120	MHz
C_{ob}^*	Output Capacitance	$V_{CB} = 10 \text{ Vdc}$, $I_E = 0$, $f = 1 \text{ MHz}$	----	150	pf
td^*	Delay Time	$I_C = 1 \text{ A}$, $I_{B1} = I_{B2} = 100 \text{ ma}$	----	60	ns
tr^*	Rise Time	$I_C = 1 \text{ A}$, $I_{B1} = I_{B2} = 100 \text{ ma}$	----	300	ns
ts^*	Storage Time	$I_C = 1 \text{ A}$, $I_{B1} = I_{B2} = 100 \text{ ma}$	----	1.7	μs
tf^*	Fall Time	$I_C = 1 \text{ A}$, $I_{B1} = I_{B2} = 100 \text{ ma}$	----	300	ns
$I_{S/B}^*$	Forward-Biased Second Breakdown	$V_{CE} = 20 \text{ Vdc}$, $t = 10 \text{ Sec}$, $T_C = 100^\circ\text{C}$ $V_{CE} = 80 \text{ Vdc}$, $t = 10 \text{ Sec}$, $T_C = 100^\circ\text{C}$	1.5 80	----	A mA
$E_{S/B}^*$	Clamped Reverse- Biased Second Breakdown	$I_C = 5 \text{ A}$, $L = 1 \text{ mH}$, $V_{Clamp} = 110 \text{ V}$, $T_C = 100^\circ\text{C}$ $I_B = 0.5 \text{ A}$, $R_{BB2} = 20\Omega$, $V_{BB2} = -3.0\text{V}$	12.5	----	mj
$E_{S/B}^*$	Unclamped Reverse- Biased Second Breakdown	$I_C = 5 \text{ A}$, $L = 1 \text{ mH}$, Base Open $I_C = 1.6 \text{ A}$, $L = 10 \text{ mH}$, Base Open	12.5 12.8	----	mj mj

Note 1: Pulse Test: PW = 300 μs , Duty Cycle $\leq 2\%$.

* Indicates MIL-S-19500/315

2N2880

PACKAGE MECHANICAL DATA

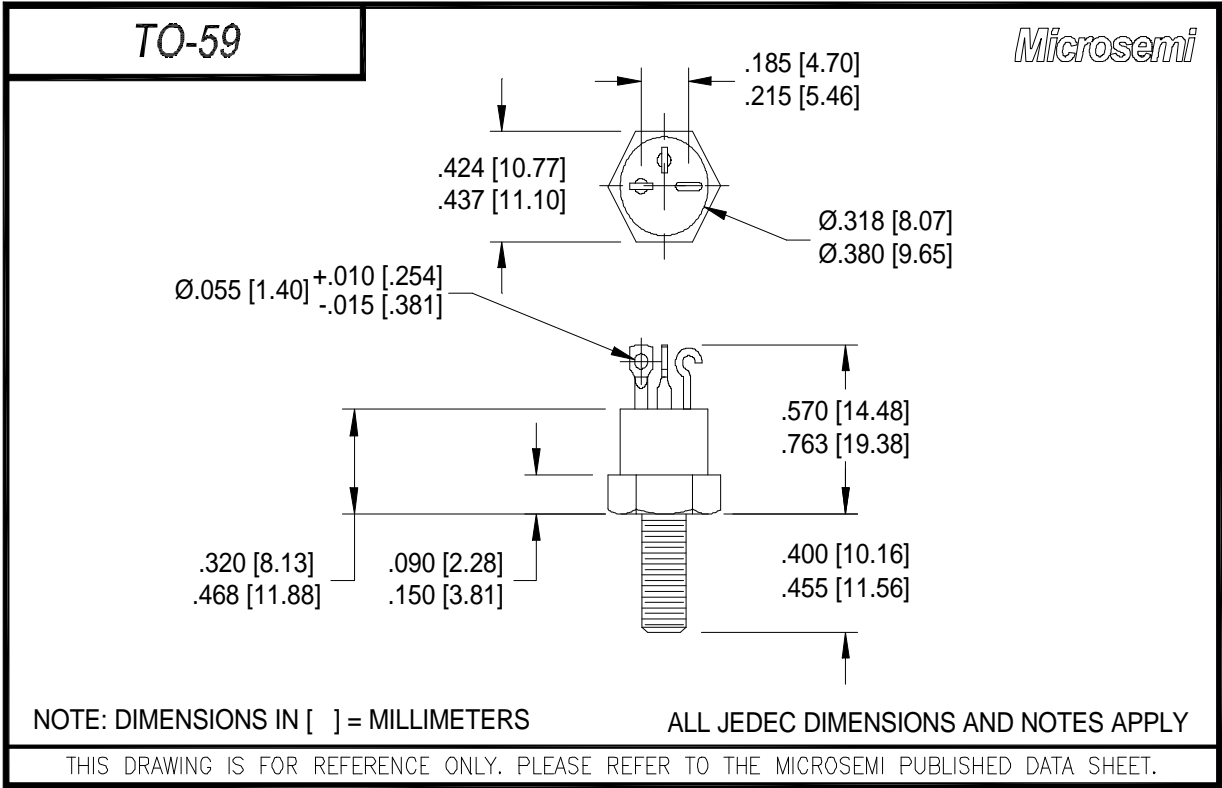



LittleDiode supplies new, hard to find or obsolete electronic components and semiconductors all over the world.

With over two million different components listed you are sure to find the part you need.

Feel free to visit us today at our online store:

LittleDiode.com

Looking forward to providing you with the best possible service.