

**1N5610  
 1N5611  
 1N5612, 1N5613**

## Features

- 1500 Watts for 1 ms Pulse Power Capability
- Small Physical Size
- Designed for MIL-STD-704A Applications

**POWER ZENER  
 RECTIFIER  
 JAN, JANTX, JANTXV**

**TRANSIENT  
 SUPPRESSOR  
 DIODE**

## Description

Zener diodes with a high surge capability  
 qualified to MIL-S-19500/434

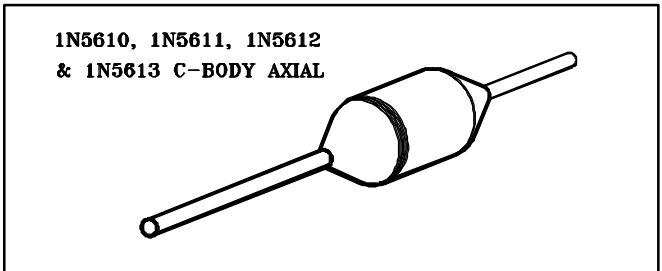

## Absolute Maximum Ratings (@ 25°C unless noted)

	<u>1N5610</u>	<u>1N5611</u>	<u>1N5612</u>	<u>1N5613</u>
Forward Surge Current,	200 A	200 A	200 A	200 A
Zener Surge Current, @ 25C	32.0 A	24.0 A	19.0 A	5.7 A
Zener Surge Current @ 150C	5.5 A	4.8 A	3.2 A	1.0 A
Storage and Operating Temperature	-65C to + 175C			
Zener Voltage	See Electrical Characteristics			
Surge Power	See Graphs			

## Electrical Characteristics (T = 25°C unless otherwise noted)

DEVICE TYPE	Min. Zener Voltage $\delta$ Vz @ 1Ma	Max. Zener Voltage $\lambda$ Vz @ Is		MAX. Reverse Leakage Current IR @ VR		MAX. Forward V $\xi$ @ 100 A	Typical Temp. Coefficient
	Volts	Volts	Amps	$\mu$ A	Volts	Volts	% / °C
1N5610*	33.0	47.5	32.0	5.0	30.5	4.8	.093
1N5611*	43.7	63.5	24.0	5.0	40.3	4.8	.094
1N5612*	54.0	78.5	19.0	5.0	49.0	4.8	.096
1N5613*	191	265	5.7	5.0	175	4.8	.100

NOTES: \* Available as JAN, JANTX and JANTXV

$\delta$  Duration of applied current  $\leq$ 300 ms, Duty cycle  $\leq$ 2%.

$\lambda$  Use a pulse which decays exponentially to 50 % of peak value during 1 ms. (See " Pulse Waveform " graph).

$\xi$  Peak Sinusoidal surge current of 8.3 ms duration, non repetitive

**1N5610  
 1N5611  
 1N5612, 1N5613**

## Applications

Voltage transients can be suppressed with series elements, shunt elements or a combination of both. These elements may be passive or active. For low & medium power applications, a series resistor & zener clamp offer several attractive features:

1. Simplicity of design.
2. High reliability.
3. Fast response time.

The 1N5610 series will suppress the following transients (defined by MIL-S-704A) without using any series limiting resistance; (except as noted in line #3 below)

1. All 600 V transients (category 1 in chart below).
2. All 80 V transients except those generated by the main voltage regulator (category 2 in chart below).
3. Over-voltage transients from the main voltage regulator (category 3 in chart below) will be suppressed if:
  - a. A 20 ohm series limiting resistor is used, or-
  - b. No series resistance is used & the zener is protected within 500  $\mu$ s, using (for example) an SCR crowbar.

The above statements are based on the source impedances & dv/dt characteristics as given in ARINC\* spec# 413; entitled "Guidance for Aircraft Electrical Power Utilization & Transient Protection. This report further defines MIL-STD-704A in regard to large aircraft electrical systems.

These surge suppressors are useful in a variety of other applications where semiconductor devices must function in an environment subject to extremely high, but short term surges.

\* ARINC stands for Aeronautical Radio Incorporated; Annapolis, Maryland 21401

Category #	Source of Trans.	Max. Amplitude	Duration of Trans.	Min. Impedance	dv over dt
1	Inductive Swtchg	600 V	$\leq 10 \mu$ s	50 ohm	---
2	BUS Switching	80 V	$\leq 10$ ms	15 ohm	---
3	Main Volt. Reg.	80 V	$\geq 10$ ms	0.2 ohm	50V/ms

**1N5610  
 1N5611  
 1N5612, 1N5613**

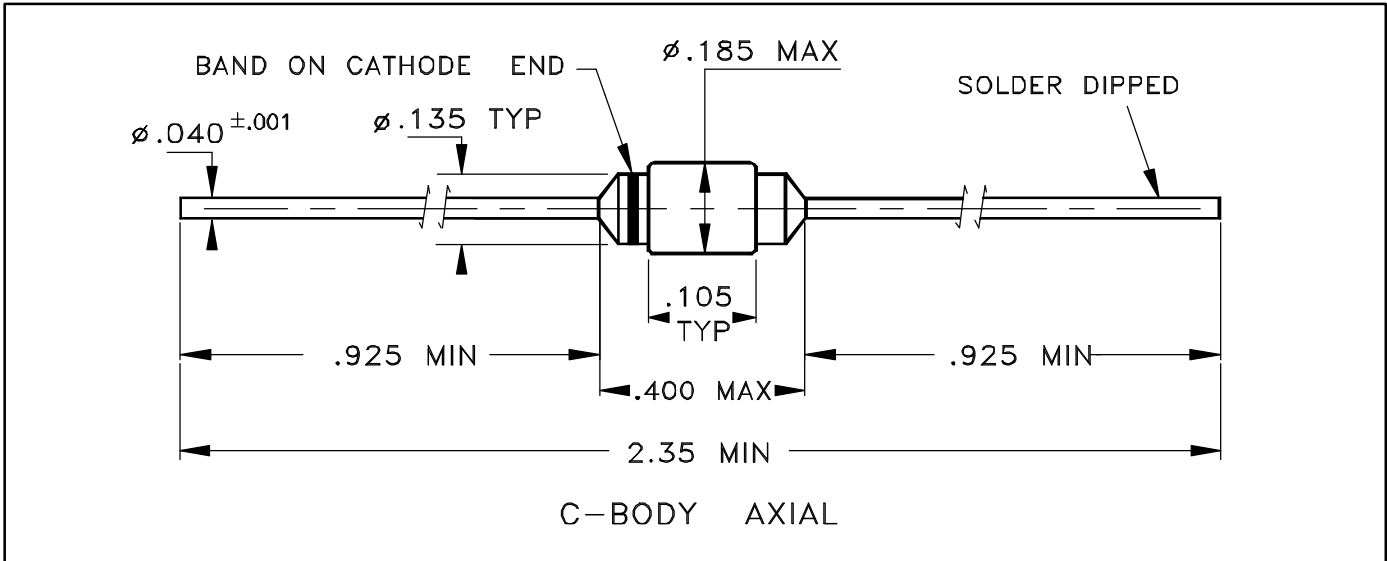

**DEVICE OUTLINE**

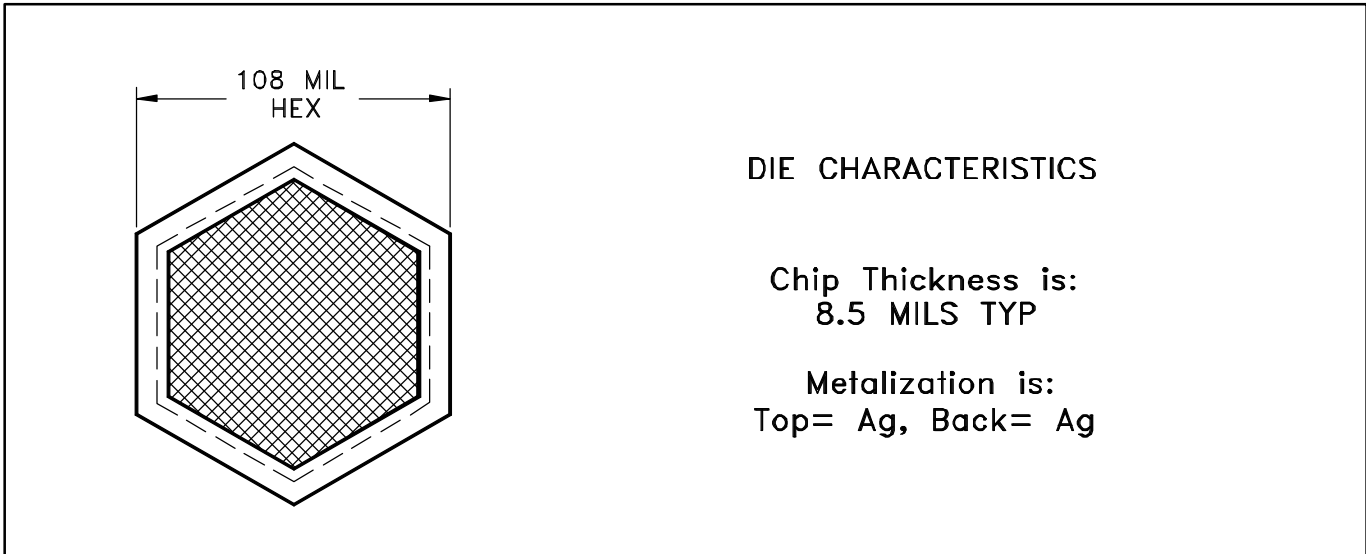

**DIE OUTLINE**

1N5610  
1N5611  
1N5612, 1N5613

**Pulse Waveform**

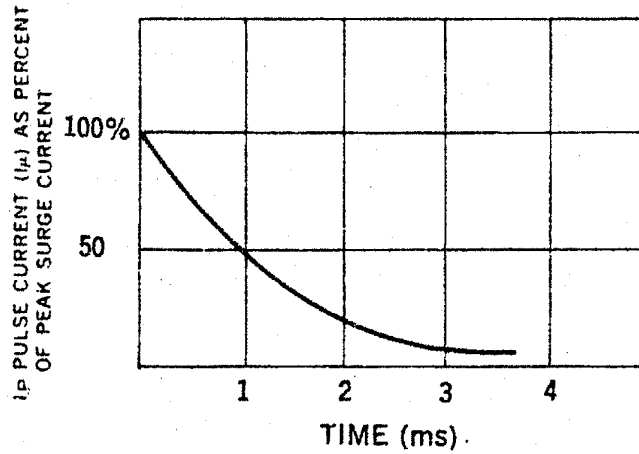

**FIGURE 1**

**Peak Power Rating\*  
vs. Ambient Temperature**

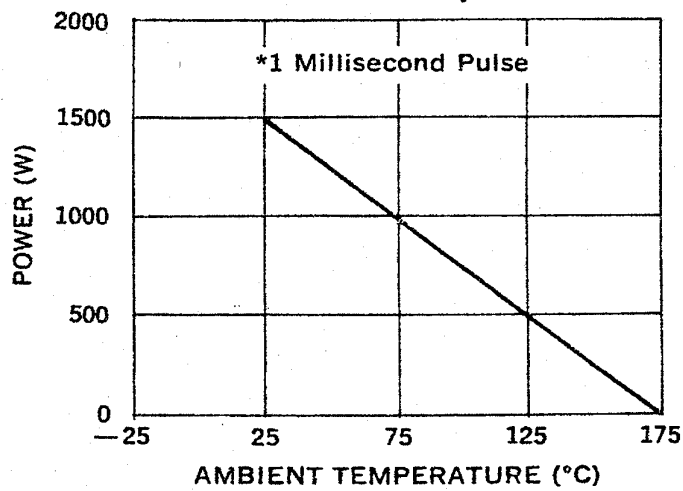

**FIGURE 2**

1N5610  
1N5611  
1N5612, 1N5613

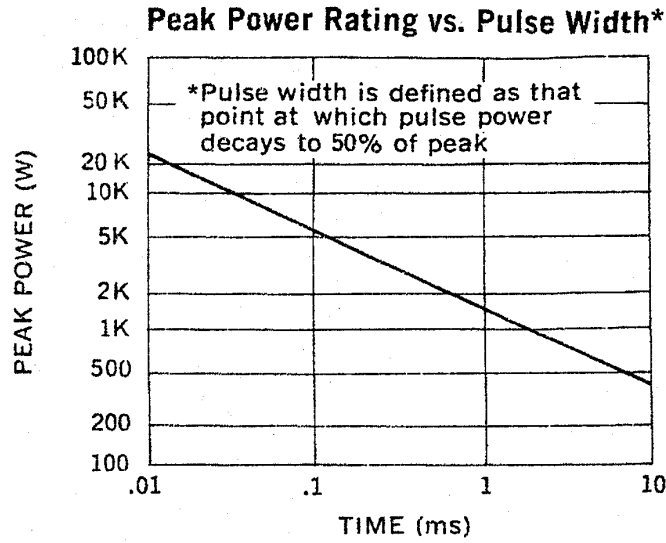

FIGURE 3



LittleDiode supplies new, hard to find or obsolete electronic components and semiconductors all over the world.

With over two million different components listed you are sure to find the part you need.

Feel free to visit us today at our online store:

[LittleDiode.com](http://LittleDiode.com)

Looking forward to providing you with the best possible service.