

LINEAR SYSTEMS

Linear Integrated Systems

IT130A IT130 IT131 IT132

MONOLITHIC DUAL PNP TRANSISTORS

FEATURES		
Direct Replacement for Intersil IT130 Series Pin for Pin Compatible		
ABSOLUTE MAXIMUM RATINGS <u>NOTE 1</u>		
(T _A = 25°C unless otherwise noted)		
I _C	Collector Current	10mA
Maximum Temperatures		
Storage Temperature Range		-65°C to +200°C
Operating Junction Temperature		+150°C
Maximum Power Dissipation		
	ONE SIDE	BOTH SIDES
Device Dissipation @ Free Air	250mW	500mW
Linear Derating Factor	2.3mW/°C	4.3mW/°C

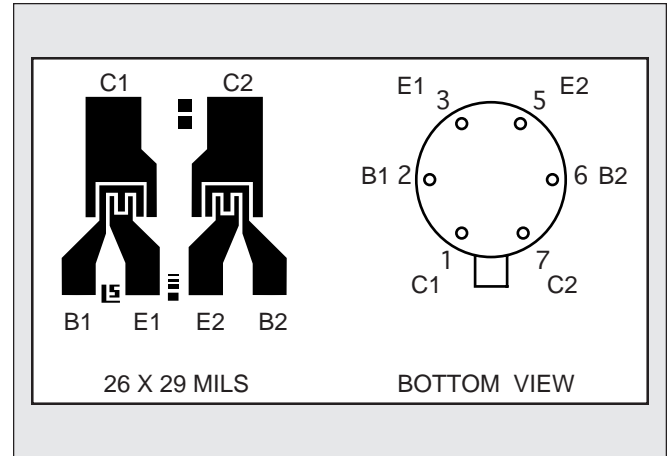

ELECTRICAL CHARACTERISTICS T_A = 25°C (unless otherwise noted)

SYMBOL	CHARACTERISTICS	IT130A	IT130	IT131	IT132		UNITS	CONDITIONS
BV _{CBO}	Collector to Base Voltage	45	45	45	45	MIN.	V	I _C = 10μA I _E = 0
BV _{CEO}	Collector to Emitter Voltage	45	45	45	45	MIN.	V	I _C = 10μA I _B = 0
BV _{EBO}	Emitter-Base Breakdown Voltage	6.2	6.2	6.2	6.2	MIN.	V	I _E = 10μA I _C = 0 <u>NOTE 2</u>
BV _{CCO}	Collector to Collector Voltage	60	60	60	60	MIN.	V	I _C = 10μA I _E = 0
h _{FE}	DC Current Gain	200	200	80	80	MIN.		I _C = 10μA V _{CE} = 5V
		225	225	100	100	MIN.		I _C = 1.0mA V _{CE} = 5V
V _{CE(SAT)}	Collector Saturation Voltage	0.5	0.5	0.5	0.5	MAX.	V	I _C = 0.5mA I _B = 0.05mA
I _{EBO}	Emitter Cutoff Current	1	1	1	1	MAX.	nA	I _C = 0 V _{EB} = 3V
I _{CBO}	Collector Cutoff Current	1	1	1	1	MAX.	nA	I _E = 0 V _{CB} = 45V
C _{OBO}	Output Capacitance	2	2	2	2	MAX.	pF	I _E = 0 V _{CB} = 5V
C _{C1C2}	Collector to Collector Capacitance	4	4	4	4	MAX.	pF	V _{CC} = 0
I _{C1C2}	Collector to Collector Leakage Current	10	10	10	10	MAX.	nA	V _{CC} = ±60V
f _T	Current Gain Bandwidth Product	110	110	90	90	MIN.	MHz	I _C = 1mA V _{CE} = 5V
NF	Narrow Band Noise Figure	3	3	3	3	MAX.	dB	I _C = 100μA V _{CE} = 5V BW = 200Hz, R _G = 10 KΩ f=1KHz

Linear Integrated Systems

4042 Clipper Court, Fremont, CA 94538 • TEL: (510) 490-9160 • FAX: (510) 353-0261

MATCHING CHARACTERISTICS @ 25°C (unless otherwise noted)

SYMBOL	CHARACTERISTICS	IT130A	IT130	IT131	IT132		UNITS	CONDITIONS
$ V_{BE1} - V_{BE2} $	Base Emitter Voltage Differential	1	2	3	5	MAX.	mV	$I_C = 10 \mu A$ $V_{CE} = 5V$
$\Delta (V_{BE1} - V_{BE2})/\Delta T$	Base Emitter Voltage Differential Change with Temperature	3	5	10	20	MAX.	$\mu V/^\circ C$	$I_C = 10 \mu A$ $V_{CE} = 5V$ $T = -55^\circ C$ to $+125^\circ C$
$ I_{B1} - I_{B2} $	Base Current Differential	2.5	5	25	25	MAX.	nA	$I_C = 10 \mu A$ $V_{CE} = 5V$

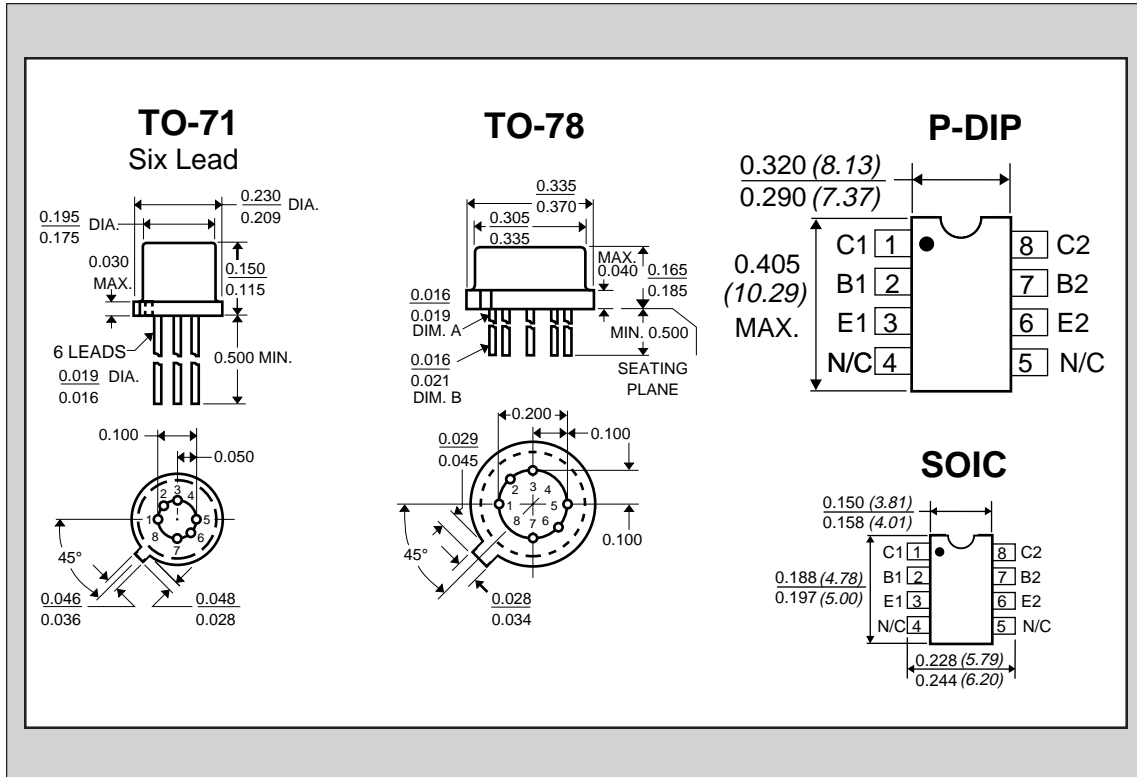

NOTES:

1. These ratings are limiting values above which the serviceability of any semiconductor may be impaired.
2. The reverse base-to-emitter voltage must never exceed 6.2 volts; the reverse base-to-emitter current must never exceed 10 μA .



LittleDiode supplies new, hard to find or obsolete electronic components and semiconductors all over the world.

With over two million different components listed you are sure to find the part you need.

Feel free to visit us today at our online store:

LittleDiode.com

Looking forward to providing you with the best possible service.