

# LINEAR SYSTEMS

Linear Integrated Systems

## IT124

### SUPER-BETA MONOLITHIC DUAL NPN TRANSISTORS

#### FEATURES

Direct Replacement for Intersil IT124

Pin for Pin Compatible

#### ABSOLUTE MAXIMUM RATINGS NOTE 1

( $T_A = 25^\circ\text{C}$  unless otherwise noted)

|                                  |                   |                   |
|----------------------------------|-------------------|-------------------|
| $I_C$                            | Collector-Current | 10mA              |
| <b>Maximum Temperatures</b>      |                   |                   |
| Storage Temperature Range        |                   | -65°C to +200°C   |
| Operating Junction Temperature   |                   | +150°C            |
| <b>Maximum Power Dissipation</b> |                   |                   |
|                                  | <b>ONE SIDE</b>   | <b>BOTH SIDES</b> |
| Device Dissipation @ Free Air    | 250mW             | 500mW             |
| Linear Derating Factor           | 2.3mW/°C          | 4.3mW/°C          |

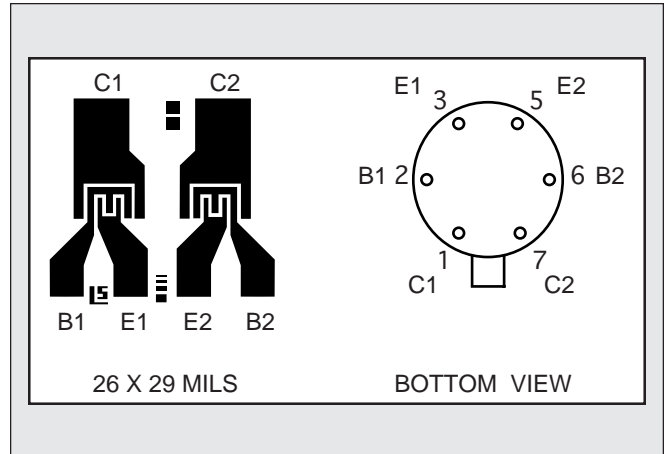

#### ELECTRICAL CHARACTERISTICS @ 25°C (unless otherwise noted)

| SYMBOL        | CHARACTERISTICS                        | IT124 |      | UNITS | CONDITIONS  |
|---------------|--|-------|------|-------|---|
| $BV_{CBO}$    | Collector-Base Breakdown Voltage       | 2     | MIN. | V     | $I_C = 10\mu\text{A}$ $I_E = 0$   |
| $BV_{CEO}$    | Collector to Emitter Voltage           | 2     | MIN. | V     | $I_C = 10\mu\text{A}$ $I_B = 0$   |
| $BV_{EBO}$    | Emitter-Base Breakdown Voltage         | 6.2   | MIN. | V     | $I_E = 10\mu\text{A}$ $I_C = 0$ NOTE 2  |
| $BV_{CCO}$    | Collector to Collector Voltage         | 100   | MIN. | V     | $I_C = 10\mu\text{A}$ $I_E = 0$   |
| $h_{FE}$      | DC Current Gain                        | 1500  | MIN. |       | $I_C = 1\mu\text{A}$ $V_{CE} = 1\text{V}$   |
| $h_{FE}$      | DC Current Gain                        | 1500  | MIN. |       | $I_C = 10\mu\text{A}$ $V_{CE} = 1\text{V}$  |
| $V_{CE(SAT)}$ | Collector Saturation Voltage           | 0.5   | MAX. | V     | $I_C = 1\text{mA}$ $I_B = 0.1\text{mA}$   |
| $I_{CBO}$     | Collector Cutoff Current               | 100   | MAX. | pA    | $I_E = 0$ $V_{CB} = 1\text{V}$  |
| $I_{EBO}$     | Emitter Cutoff Current                 | 100   | MAX. | pA    | $I_C = 0$ $V_{EB} = 3\text{V}$  |
| $C_{OBO}$     | Output Capacitance                     | 2     | MAX. | pF    | $I_E = 0$ $V_{CB} = 1\text{V}$  |
| $C_{C1C2}$    | Collector to Collector Capacitance     | 2     | MAX. | pF    | $V_{CC} = 0$  |
| $I_{C1C2}$    | Collector to Collector Leakage Current | 250   | MAX. | pA    | $V_{CC} = \pm 50\text{V}$   |
| $f_T$         | Current Gain Bandwidth Product         | 100   | MIN. | MHz   | $I_C = 100\mu\text{A}$ $V_{CE} = 1\text{V}$   |
| NF            | Narrow Band Noise Figure               | 3     | MAX. | dB    | $I_C = 10\mu\text{A}$ $V_{CE} = 3\text{V}$<br>$R_G = 10\text{K}\Omega$ $f = 1\text{KHz}$<br>$BW = 200\text{Hz}$ |

Linear Integrated Systems

4042 Clipper Court, Fremont, CA 94538 • TEL: (510) 490-9160 • FAX: (510) 353-0261

**MATCHING CHARACTERISTICS @ 25°C** (unless otherwise noted)

| SYMBOL                               | CHARACTERISTICS   | IT124   |              | UNITS                                | CONDITIONS   |
|--------------------------------------|---|---------|--------------|--------------------------------------|--|
| $ V_{BE1} - V_{BE2} $                | Base Emitter Voltage Differential                         | 2<br>5  | TYP.<br>MAX. | mV<br>mV                             | $I_C = 10 \mu A$<br>$V_{CE} = 1V$  |
| $\Delta(V_{BE1} - V_{BE2})/\Delta T$ | Base Emitter Voltage Differential Change with Temperature | 5<br>15 | TYP.<br>MAX. | $\mu V/^\circ C$<br>$\mu V/^\circ C$ | $I_C = 10 \mu A$<br>$V_{CE} = 1V$<br>$T = -55^\circ C$ to $+125^\circ C$ |
| $ I_{B1} - I_{B2} $                  | Base Current Differential                                 | 0.6     | MAX.         | nA                                   | $I_C = 10 \mu A$<br>$V_{CE} = 1V$  |

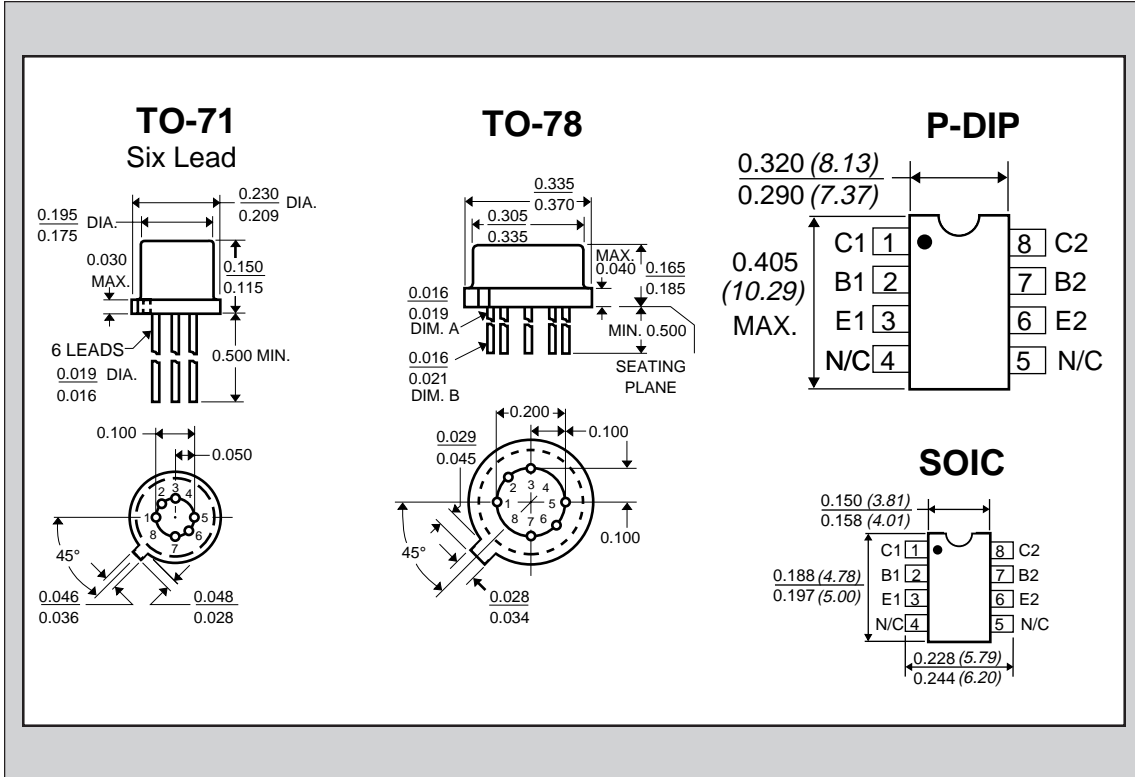

**NOTES:**

1. These ratings are limiting values above which the serviceability of any semiconductor may be impaired.
2. The reverse base-to-emitter voltage must never exceed 6.2 volts; the reverse base-to-emitter current must never exceed 10  $\mu A$ .



LittleDiode supplies new, hard to find or obsolete electronic components and semiconductors all over the world.

With over two million different components listed you are sure to find the part you need.

Feel free to visit us today at our online store:

[LittleDiode.com](http://LittleDiode.com)

Looking forward to providing you with the best possible service.