

International Rectifier IRFK2DC50, IRFK2FC50

Isolated Base Power HEX-pak™ Assembly - Half Bridge Configuration

- High Current Capability.
- UL recognised E78996.
- Electrically Isolated Base Plate.
- Easy Assembly into Equipment.



Description

The HEX-pak™ utilises the well-proven HEXFET™ die, combining low on-state resistance with high transconductance. These superior technology die are assembled by state of the art techniques into the TO-240 package, featuring 2.5kV rms isolation and solid M5 screw connections. The small footprint means the package is highly suited to power applications where space is a premium. Available in two versions, IRFK.D... for fast switching and IRFK.F... for oscillation sensitive applications.

$$V_{DS} = 600V$$

$$R_{DS(on)} = 300m\Omega$$

$$I_D = 18A$$

Absolute Maximum Rating

	Parameter	Max.	Units
$I_D @ T_C=25^\circ C$	Continuous Drain Current	18	A
$I_D @ T_C=100^\circ C$	Continuous Drain Current	11	A
I_{DM}	Pulse Drain Current	72	A ①
$P_D @ T_C=25^\circ C$	Maximum Power Dissipation	500	W
V_{GS}	Gate-to-Source Voltage	20	V
V_{INS}	R.M.S. Isolation Voltage, circuit to base	2.5	kV
T_J	Operating Junction Temperature Range	-40 to 150	°C
T_{STG}	Storage Temperature Range	-40 to 150	°C

Thermal and Mechanical Specifications

	Parameter	Min.	Typ.	Max.	Units
R_{thJC}	Junction-to-Case	-	-	0.25	K/W ②
R_{thCS}	Case-to-Sink, smooth & greased surface	-	0.1	-	K/W
T	Mounting Torque +10%				③
	HEXpak to Heatsink Busbar to HEXpak	-	5 3	-	Nm Nm
wt	Approximate Weight	-	140	-	g
		-	5	-	oz

Notes:

- ① - Repetitive Rating: Pulse width limited by maximum junction temperature see figure 8.
- ② - Per Module.
- ③ - A mounting compound is recommended and the torque should be rechecked after a period of three hours to allow for the spread of the compound.

IRFK2DC50, IRFK2FC50



Electrical Characteristics @ T_J = 25°C (Unless otherwise specified)

	Parameter	Min.	Typ.	Max.	Units	Test Conditions	
B _{VDS}	Drain-to-Source Breakdown voltage	600	-	-	V	V _{GS} =0V, I _D =1.0mA	
R _{DS(on)}	Static Drain-to-Source On-State Resistance	-	250	300	mΩ	V _{GS} =10V, I _D =11A	
I _{D(on)}	On-State Drain Current	18	-	-	A	V _{DS} > I _{D(on)} × R _{DS(on)} max, V _{GS} =10V	
V _{GS(th)}	Gate Threshold Voltage	2.0	-	4.0	V	V _{DS} =V _{GS} , I _D =1.0mA	
g _{fs}	Forward Transconductance ④	16	26	-	S	V _{DS} > 50V, I _D =11A	
I _{DSS}	Zero Gate Voltage Drain Current	-	-	0.5	mA	V _{DS} =V _{DS} max, V _{GS} =0V	
		-	-	2.0	mA	V _{GS} =10V, T _C =125°C, V _{DS} =V _{DS} max × 0.8	
I _{GSS}	Gate-to-Source Leakage Forward	-	-	200	nA	V _{GS} =20V	
I _{GSS}	Gate-to-Source Leakage Reverse	-	-	-200	nA	V _{GS} =-20V	
Q _g	Total Gate Charge	-	220	260	nC	I _D =18A, V _{GS} =10V,	
Q _{gs}	Gate-to-Source Charge	-	25	40	nC	V _{DS} =V _{DS} max × 0.8	
Q _{gd}	Gate-to-Drain ("Miller") Charge	-	180	120	nC		
t _{d(on)}	Turn-on Delay Time	IRFK2DC50	-	40	-	ns	V _{DD} =300V, I _D =11A,
		IRFK2FC50	-	45	-	ns	
t _r	Rise Time	IRFK2DC50	-	50	-	ns	V _{GS} =10V,
		IRFK2FC50	-	65	-	ns	
t _{d(off)}	Turn-off Delay Time	IRFK2DC50	-	240	-	ns	R _{SOURCE} =3.3Ω
		IRFK2FC50	-	320	-	ns	
t _f	Fall Time	IRFK2DC50	-	50	-	ns	
		IRFK2FC50	-	80	-	ns	
L _{DS}	Drain-to-Source Inductance	-	18	-	nH		
C _{iss}	Input Capacitance	-	5.2	-	nF	V _{GS} =0V, V _{DS} =25V,	
C _{oss}	Output Capacitance	-	0.8	-	nF	f=1.0MHz	
C _{rss}	Reverse Transfer Capacitance	-	0.35	-	nF		
	Linear Derating Factor	-	-	4	W/K		

Source-Drain Diode Ratings and Characteristics

	Parameter	Min.	Typ.	Max.	Units	Test Conditions
I _S	Continuous Source Current (Body Diode)	-	-	18	A	
I _{SM}	Pulsed Source Current (Body Diode)	-	-	67	A	
V _{SD}	Diode Forward Voltage	-	-	1.4	V	V _{GS} =0V, I _S =18A, T _C =25°C
t _{rr}	Reverse Recovery Time	270	550	1100	ns	di/dt=200A/μs, T _J =150°C
Q _{rr}	Reverse Recovered Charge	4.0	8.2	16.4	μC	I _S =18A

Notes:

④ - Pulse Width ≤ 300μs; Duty cycle ≤ 2%.



IRFK2DC50, IRFK2FC50

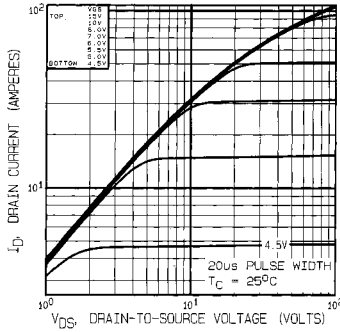

Fig 1. Typical Output Characteristics,
 $T_C=25^\circ\text{C}$

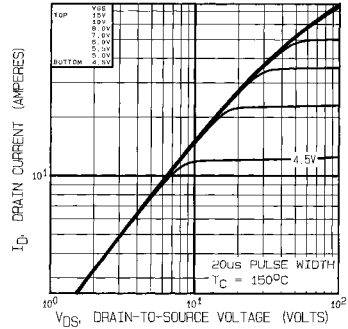

Fig 2. Typical Output Characteristics,
 $T_C=150^\circ\text{C}$

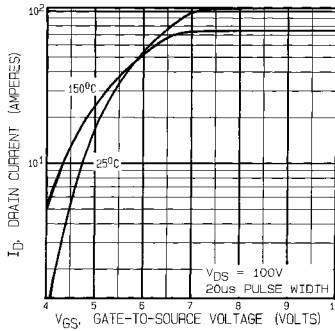

Fig 3. Typical Transfer Characteristics

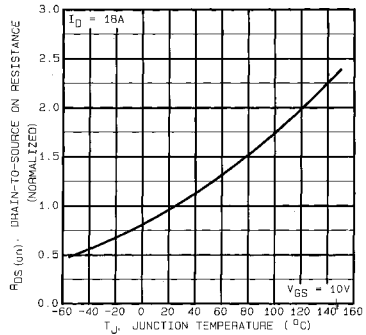

Fig 4. Normalized On-Resistance Vs.
D Temperature

IRFK2DC50, IRFK2FC50

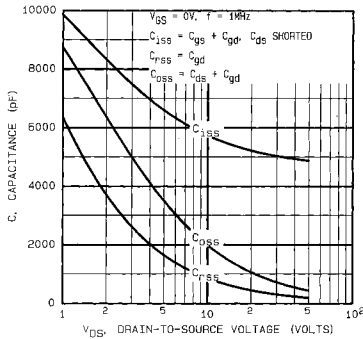

Fig 5. Typical Capacitance Vs. Drain-to-Source Voltage

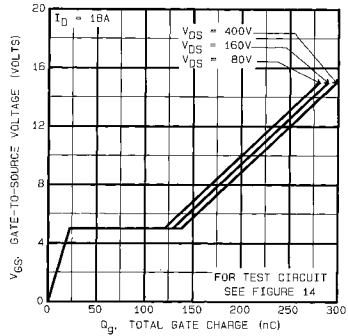

Fig 6. Typical Gate Charge Vs. Gate-to-Source Voltage

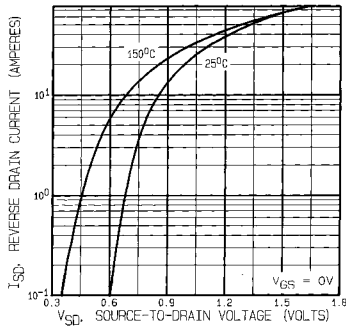

Fig 7. Typical Source-Drain Diode Forward Voltage

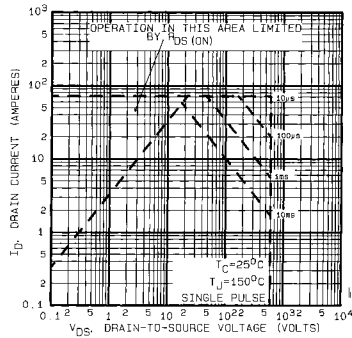

Fig 8. Maximum Safe Operating Area



IRFK2DC50, IRFK2FC50

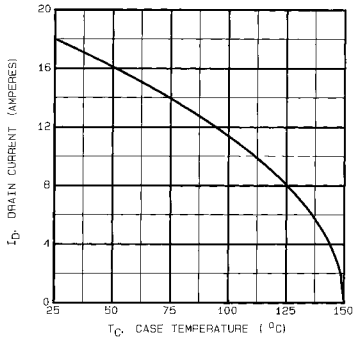

Fig 9. Maximum Drain Current Vs. Case Temperature

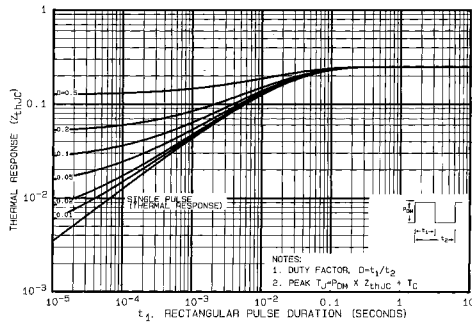

Fig 10. Maximum Effective Transient Thermal Impedance, Junction-to-Case

IRFK2DC50,IRFK2FC50

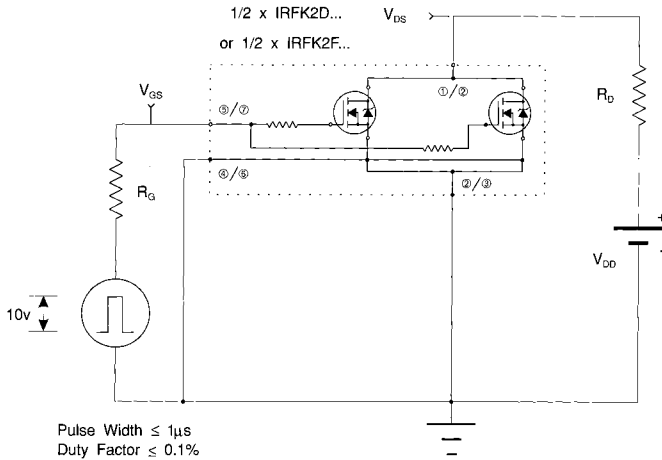

Fig 11a. Switching Time Test Circuit

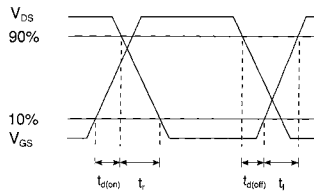
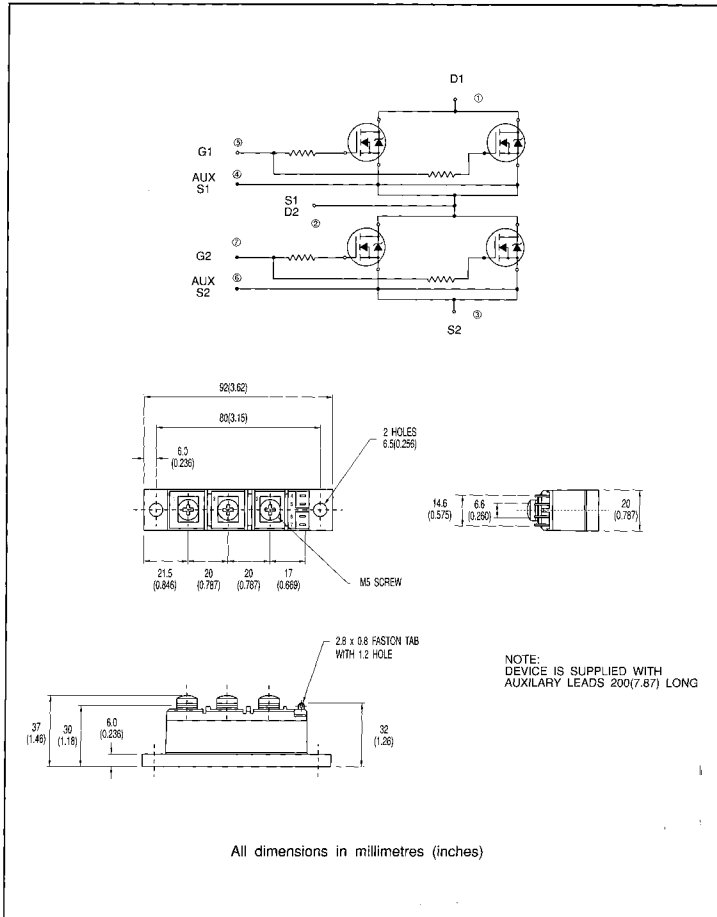

Fig 11b. Switching Time Waveforms



IRFK2DC50, IRFK2FC50

Circuit Configuration and Outline



IRFK2DC50,IRFK2FC50



Part Numbering

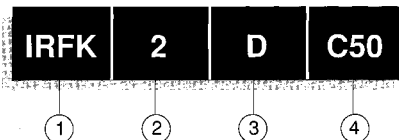

1. - HEX-pak Module.
2. - Number of arms of bridge.
3. - D - Fast switching.
- F - Oscillation resistant for sensitive applications.
4. - Voltage code:-
054 - 60V
150 - 100V
250 - 200V
350 - 400V
450 - 500V
C50 - 600V

WORLD HEADQUARTERS: 233 Kansas St., EL SEGUNDO, California 90245, U.S.A. Tel:(213) 772-2000, Tlx:664464, Fax:(213) 772-9028
EUROPEAN HEADQUARTERS: Hurst Green, OXTEJ, Surrey RH8 9BB, UK. Tel:(0883) 713215, Tlx:95219, Fax:(0883)714234.

CANADA: 101 Bentley St., Markham, ONTARIO L3R 3L1, Tel:(416)475-1897, Tlx:06-966-650, Fax:(416)475-8801
CZECHOSLOVAKIA: Masurova 19/156b, Box 30, 149 00 PRAGUE, Tel:(21) 792 6831, Fax:(2) 792 6831.
DENMARK: P.O. Box 70, Krogshøjvej 51, DK-2880 BAGSVAERD, Tel:(45) 44 37 71 50, Fax:(45) 44 37 71 52.
FRANCE: 123 Rue de Petit Vaux, 91360 EPINAY sur ORGE, Tel:(1)64.54.83.29, Tlx:600943, Fax:(1)64.54.83.30.
FINLAND: Biliskogsvägen 19, 02580 Sjunåvä 3 St, Tel:(0) 262 8144, Fax:(0) 262 8150.
GERMANY: Sealsburgstr. 157, D-6380 BAD HOMBURG, Tel:(61)72 37066, Tlx:410404, Fax:(61)72 37065.
HUNGARY: Szent Istvan Park 15, H-1137 BUDAPEST, Tel:(1) 1298 922, Fax:(1) 1298 922.
HONG KONG: 202 Peter Building, 60 Queens Road Central, HONG KONG, Tel:(85) 252 36355, Fax:(85) 284 52908.
ITALY: Via Liguria 49, 10071 Borgaro, TORINO, Tel:(011)470 14 84, Tlx:221257, Fax:(011)470 42 90.
Via Zucca 8, 20017 Rho MILANO, Tel:(02)93 50 36 50, Fax:(02)93 50 36 55.
Via Arno 1, 40139 BOLOGNA, Tel:(051)49 33 07, Fax:(051)49 54 90.
INDIA: 31 Greenacre, 5 Union Park, Kher (W), BOMBAY 400 052, Tel:(022)535026/533779/540242, Tlx:011-71481.
JAPAN: K & H Bldg. 2F, 3-30-4 Nishi-Kebukuro, Toshima-ku, TOKYO, Japan 171, Tel:(03)983 0641, Fax:(03)983 0642.
SINGAPORE: HEX 10-01 Fortune Centre, 190 Middle Road, SINGAPORE 0718, Tel:(65)536 3922/337 4695/335 8286, Fax:(65)337 4692.
SWEDEN: Box: 86, S-162 12 Vallingsby 1, STOCKHOLM, Tel:(08)870035, Fax:(08)874242.
SWITZERLAND: CH-8032 ZÜRICH, Kirchenweg 5, Tel:(01)986 6702/6886, Fax:(01)983 5106/2379.
U.S.A.:
Central Zone: 2401 Plum Grove Road, Suite 111, PALATINE, IL60067, Tel:(312)387-0002, Fax:(312)397-0114.
Eastern Zone: 71 Grand Avenue, PALISADES PARK, NJ07650, Tel:(201)943-4554, Fax:(201)943-5754.
Southern Zone: 800 Office Plaza Blvd., Suite 401, KISSIMMEE, FL32743, Tel:(407)933-2383, Fax:(407)933-2293.
Western Zone: 222 Kansas Street, EL SEGUNDO, CA90245, Tel:(213)607-6886, Fax:(213)640-6533.

Sales Offices, Agents and Distributors in Major Cities throughout the World.

In the interest of product improvement INTERNATIONAL RECTIFIER reserves the right to change specifications at any time without notice.

M.JW/1/82



LittleDiode supplies new, hard to find or obsolete electronic components and semiconductors all over the world.

With over two million different components listed you are sure to find the part you need.

Feel free to visit us today at our online store:

LittleDiode.com

Looking forward to providing you with the best possible service.