

Absolute Maximum Ratings

Parameter	IRFI460	Units
I_D @ $V_{GS} = 0V, T_C = 25^\circ C$ Continuous Drain Current	21	A
I_D @ $V_{GS} = 0V, T_C = 100^\circ C$ Continuous Drain Current	13	
I_{DM} Pulsed Drain Current ①	84	
P_D @ $T_C = 25^\circ C$ Max. Power Dissipation	300	W
Linear Derating Factor	2.4	W/K ⑤
V_{GS} Gate-to-Source Voltage	± 20	V
E_{AS} Single Pulse Avalanche Energy ②	480	mJ
I_{AR} Avalanche Current ①	21	A
E_{AR} Repetitive Avalanche Energy ①	30	mJ
dv/dt Peak Diode Recovery dv/dt ③	3.5	V/ns
T_J Operating Junction Temperature	-55 to 150	°C
T_{STG} Storage Temperature Range		
Lead Temperature	300 (0.063 in. (1.6 mm) from case for 10s)	
Weight	10.5 (typical)	g

Electrical Characteristics @ $T_J = 25^\circ C$ (Unless Otherwise Specified)

Parameter	Min.	Typ.	Max.	Units	Test Conditions
BV_{DSS} Drain-to-Source Breakdown Voltage	500	—	—	V	$V_{GS} = 0V, I_D = 1.0 \mu A$
$\Delta BV_{DSS}/\Delta T_J$ Temperature Coefficient of Breakdown Voltage	—	0.63	—	V/°C	Reference to $25^\circ C, I_D = 1.0 mA$
$R_{DS(on)}$ Static Drain-to-Source On-State Resistance	—	—	0.27	Ω	$V_{GS} = 10V, I_D = 13A$ ④
	—	—	0.31		$V_{GS} = 10V, I_D = 21A$
$V_{GS(th)}$ Gate Threshold Voltage	2.0	—	4.0	V	$V_{DS} = V_{GS}, I_D = 250 \mu A$
g_{fs} Forward Transconductance	13	—	—	S (b)	$V_{DS} = 15V, I_{DS} = 13A$ ④
I_{DSS} Zero Gate Voltage Drain Current	—	—	25	μA	$V_{DS} = 0.8 \times \text{Max. Rating}, V_{GS} = 0V$
	—	—	250		$V_{DS} = 0.8 \times \text{Max. Rating}, V_{GS} = 0V, T_J = 125^\circ C$
I_{GSS} Gate-to-Source Leakage Forward	—	—	100	nA	$V_{GS} = 20V$
I_{GSS} Gate-to-Source Leakage Reverse	—	—	-100		$V_{GS} = -20V$
Q_g Total Gate Charge	—	—	190	nC	$V_{GS} = 10V, I_D = 21A$
Q_{gs} Gate-to-Source Charge	—	—	27		$V_{DS} = 0.5 \times \text{Max. Rating}$
Q_{gd} Gate-to-Drain ("Miller") Charge	—	—	135		See Fig. 6 and 14
$t_{d(on)}$ Turn-On Delay Time	—	—	35	ns	$V_{DD} = 250V, I_D = 21A, R_G = 2.35\Omega$ See Fig. 11
t_r Rise Time	—	—	120		
$t_{d(off)}$ Turn-Off Delay Time	—	—	130		
t_f Fall Time	—	—	98		
L_D Internal Drain Inductance	—	8.7	—	nH	Measured from the drain lead, 6 mm (0.25 in.) from package to center of die. Modified MOSFET symbol showing the internal inductances.
L_S Internal Source Inductance	—	8.7	—		
C_{iss} Input Capacitance	—	4300	—	pF	$V_{GS} = 0V, V_{DS} = 25V$ $f = 1.0 MHz$ See Fig. 5
C_{oss} Output Capacitance	—	1000	—		
C_{riss} Reverse Transfer Capacitance	—	250	—		

Source-Drain Diode Ratings and Characteristics

Parameter	Min.	Typ.	Max.	Units	Test Conditions
I_S Continuous Source Current (Body Diode)	—	—	21	A	Modified MOSFET symbol showing the integral Reverse p-n junction rectifier. 
I_{SM} Pulsed Source Current (Body Diode) ①	—	—	84		
V_{SD} Diode Forward Voltage	—	—	1.8	V	$T_J = 25^\circ\text{C}$, $I_S = 21\text{A}$, $V_{GS} = 0\text{V}$ ②
t_{rr} Reverse Recovery Time	—	—	580	nS	$T_J = 25^\circ\text{C}$, $I_F = 21\text{A}$, $di/dt \leq 100 \text{ A}/\mu\text{s}$ ④
Q_{RR} Reverse Recovery Charge	—	—	8.1	μC	$V_{DD} \leq 50\text{V}$
t_{on} Forward Turn-On Time	Intrinsic turn-on time is negligible. Turn-on speed is substantially controlled by $L_S + L_D$.				

Thermal Resistance

Parameter	Min.	Typ.	Max.	Units	Test Conditions
R_{thJC} Junction-to-Case	—	—	0.42	K/W ⑤	
R_{thCS} Case-to-Sink	—	0.21	—		Mounting surface flat, smooth, and greased
R_{thJA} Junction-to-Ambient	—	—	30		Typical socket mount

① Repetitive Rating; Pulse width limited by maximum junction temperature (see figure 9) Refer to current HEXFET reliability report

② @ $V_{DD} = 50\text{V}$, Starting $T_J = 25^\circ\text{C}$, $L = 2.0 \text{ mH}$, $R_G = 25\Omega$, Peak $I_L = 21\text{A}$

③ $I_{SD} \leq 21\text{A}$, $di/dt \leq 160 \text{ A}/\mu\text{s}$, $V_{DD} \leq BV_{DSS}$, $T_J \leq 150^\circ\text{C}$, Suggested $R_G = 2.35\Omega$

④ Pulse width $\leq 300 \mu\text{s}$; Duty Cycle $\leq 2\%$

⑤ $K/W = ^\circ\text{C}/\text{W}$
 $W/K = \text{W}/^\circ\text{C}$

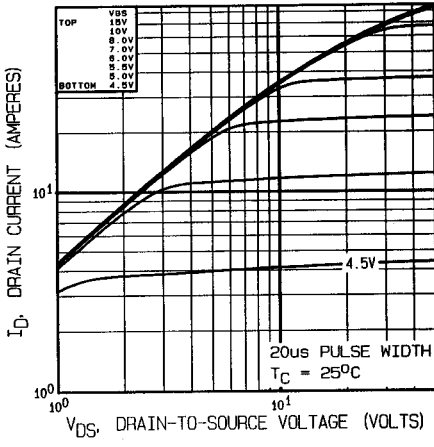

Fig. 1 — Typical Output Characteristics, $T_C = 25^\circ\text{C}$

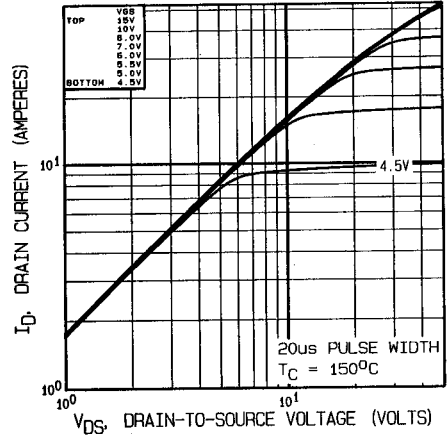

Fig. 2 — Typical Output Characteristics, $T_C = 150^\circ\text{C}$

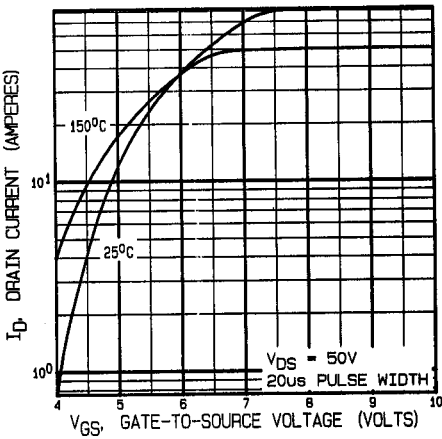

Fig. 3 — Typical Transfer Characteristics

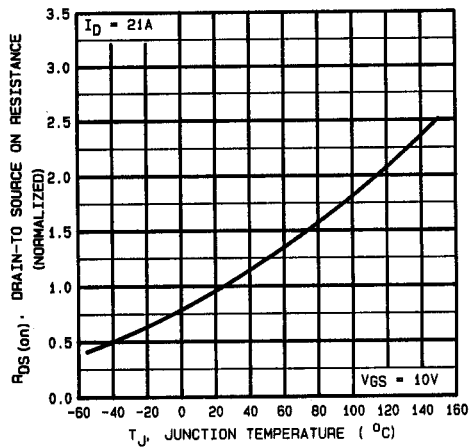
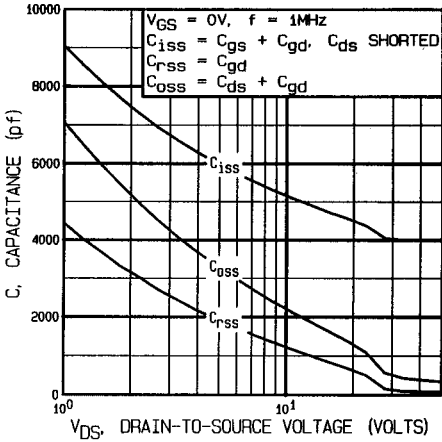
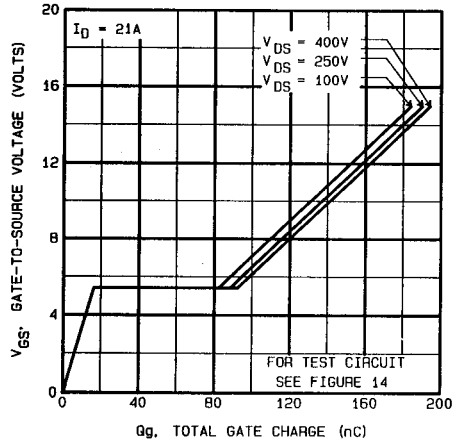
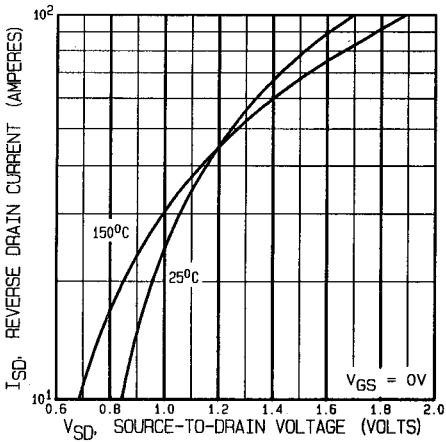
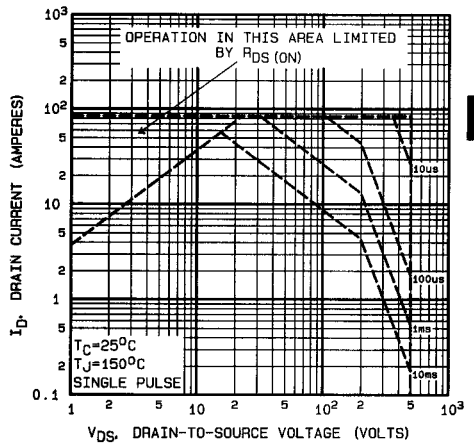

Fig. 4 — Normalized On-Resistance Vs. Temperature

Fig. 5 — Typical Capacitance Vs. Drain-to-Source Voltage

Fig. 6 — Typical Gate Charge Vs. Gate-to-Source Voltage

Fig. 7 — Typical Source-Drain Diode Forward Voltage

Fig. 8 — Maximum Safe Operating Area

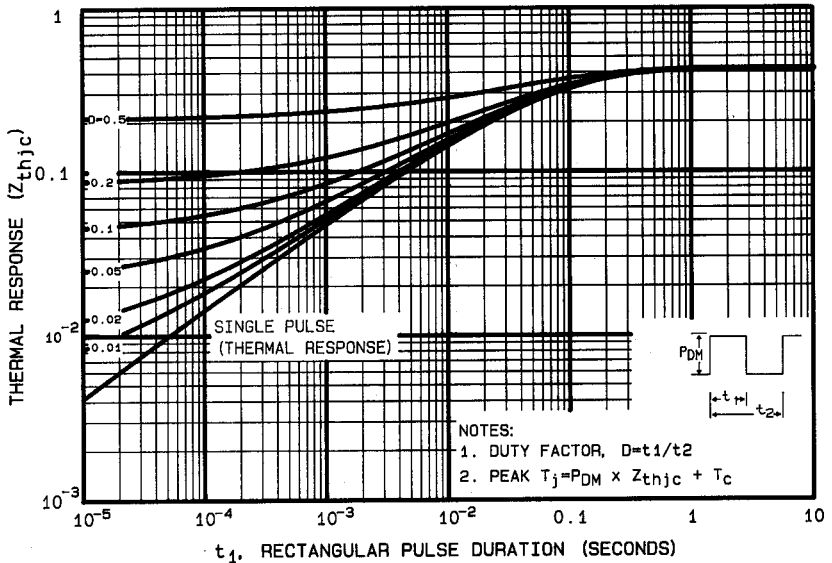

Fig. 9 — Maximum Effective Transient Thermal Impedance, Junction-to-Case Vs. Pulse Duration

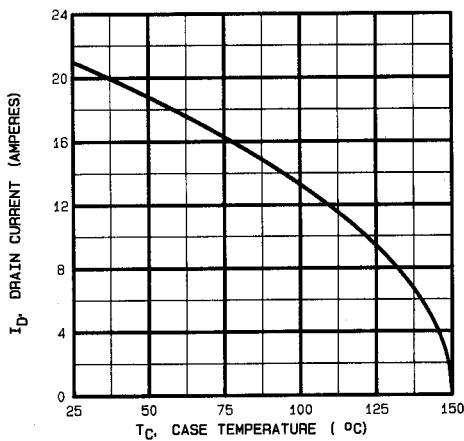

Fig. 10 — Maximum Drain Current Vs. Case Temperature

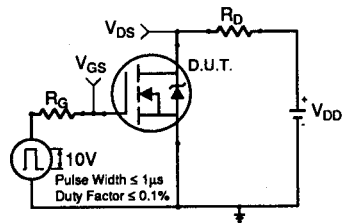

Fig. 11a — Switching Time Test Circuit

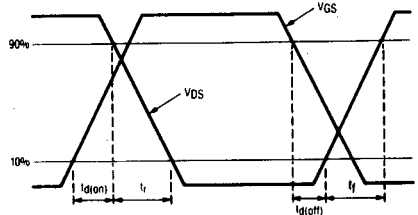
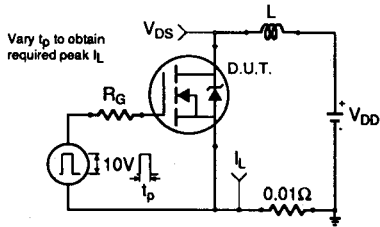
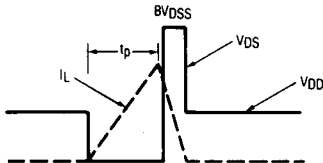
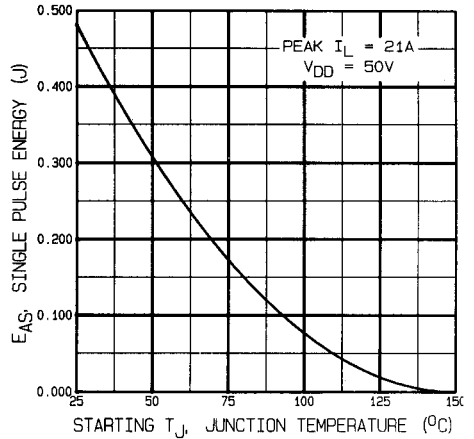
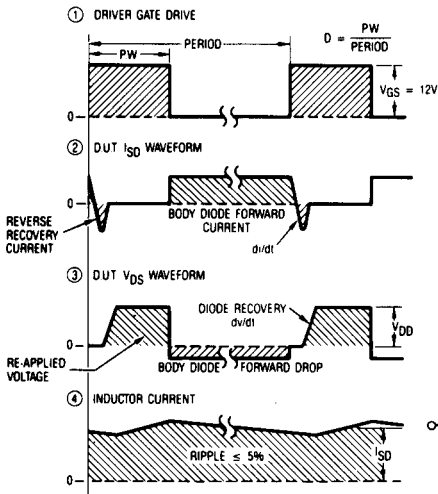
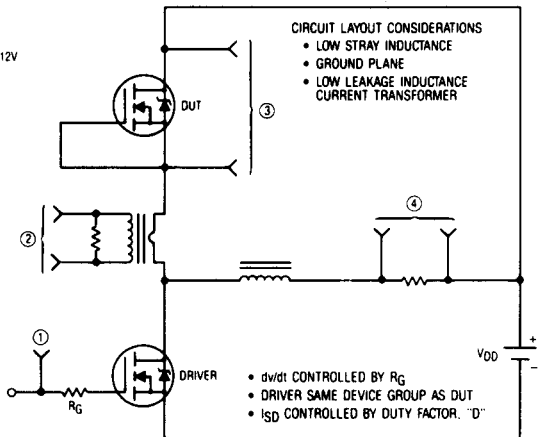

Fig. 11b — Switching Time Waveforms

Fig. 12a — Unclamped Inductive Test Circuit

Fig. 12b — Unclamped Inductive Waveforms

Fig. 12c — Maximum Avalanche Energy Vs. Starting Junction Temperature

Fig. 13 — Peak Diode Recovery dv/dt Test Circuit

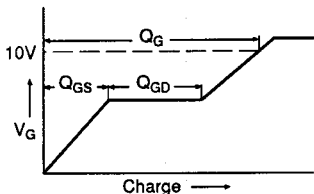

Fig. 14a — Basic Gate Charge Waveform

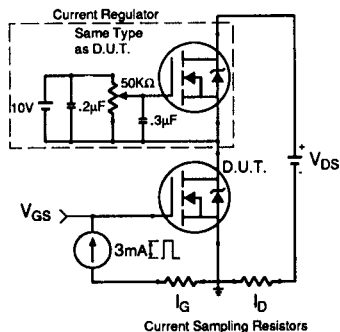

Fig. 14b — Gate Charge Test Circuit

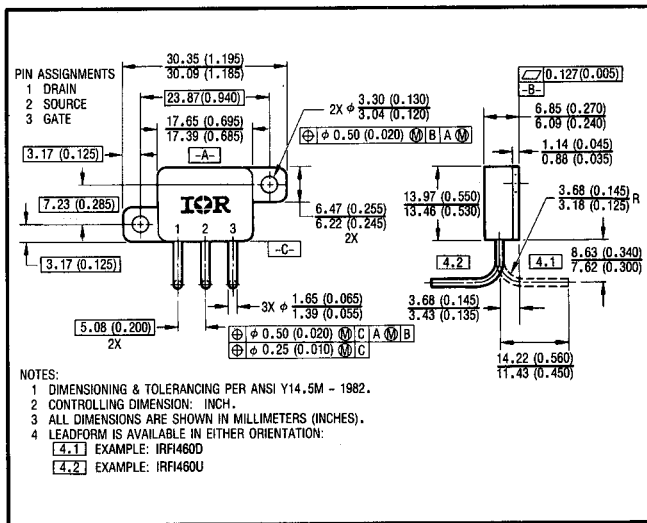

Fig. 15 — Optional Leadforms for Outline TO-259

BERYLLIA WARNING PER MIL-S-19500

Packages containing beryllia shall not be ground, sandblasted, machined, or have other operations performed on them which will produce beryllia or beryllium dust. Furthermore, beryllium oxide packages shall not be placed in acids that will produce fumes containing beryllium.



LittleDiode supplies new, hard to find or obsolete electronic components and semiconductors all over the world.

With over two million different components listed you are sure to find the part you need.

Feel free to visit us today at our online store:

LittleDiode.com

Looking forward to providing you with the best possible service.