

# IRF5851

HEXFET® Power MOSFET

- Ultra Low On-Resistance
- Dual N and P Channel MOSFET
- Surface Mount
- Available in Tape & Reel
- Low Gate Charge

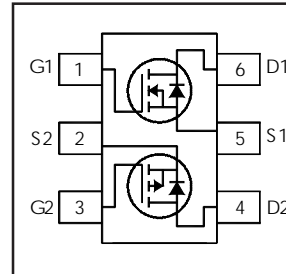

	N-Ch	P-Ch
$V_{DS}$	20V	-20V
$R_{DS(on)}$	0.090 $\Omega$	0.135 $\Omega$

## Description

These N and P channel MOSFETs from International Rectifier utilize advanced processing techniques to achieve the extremely low on-resistance per silicon area. This benefit provides the designer with an extremely efficient device for use in battery and load management applications.

This Dual TSOP-6 package is ideal for applications where printed circuit board space is at a premium and where maximum functionality is required. With two die per package, the IRF5851 can provide the functionality of two SOT-23 packages in a smaller footprint. Its unique thermal design and  $R_{DS(on)}$  reduction enables an increase in current-handling capability.

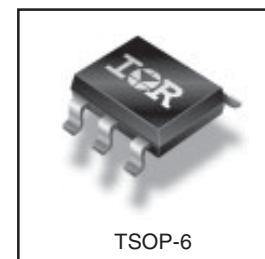

## Absolute Maximum Ratings

	Parameter	Max.		Units
		N-Channel	P-Channel	
$V_{DS}$	Drain-to-Source Voltage	20	-20	A
$I_D @ T_A = 25^\circ\text{C}$	Continuous Drain Current, $V_{GS} @ 10\text{V}$	2.7	-2.2	
$I_D @ T_A = 70^\circ\text{C}$	Continuous Drain Current, $V_{GS} @ 10\text{V}$	2.2	-1.7	
$I_{DM}$	Pulsed Drain Current ①	11	-9.0	
$P_D @ T_A = 25^\circ\text{C}$	Power Dissipation ③	0.96		W
$P_D @ T_A = 70^\circ\text{C}$	Power Dissipation ③	0.62		
	Linear Derating Factor	7.7		mW/°C
$V_{GS}$	Gate-to-Source Voltage	$\pm 12$		V
$T_J, T_{STG}$	Junction and Storage Temperature Range	-55 to + 150		°C

## Thermal Resistance

	Parameter	Typ.	Max.	Units
$R_{\theta JA}$	Maximum Junction-to-Ambient ③	—	130	°C/W

## Electrical Characteristics @ $T_J = 25^\circ\text{C}$ (unless otherwise specified)

Parameter	Description		Min.	Typ.	Max.	Units	Conditions
$V_{(BR)DSS}$	Drain-to-Source Breakdown Voltage		20	—	—	V	$V_{GS} = 0V, I_D = 250\mu A$ $V_{GS} = 0V, I_D = -250\mu A$
$\Delta V_{(BR)DSS}/\Delta T_J$	Breakdown Voltage Temp. Coefficient		—	0.016	—	V/°C	Reference to $25^\circ\text{C}, I_D = 1\text{mA}$ Reference to $25^\circ\text{C}, I_D = -1\text{mA}$
$R_{DS(on)}$	Static Drain-to-Source On-Resistance	N-Ch	—	—	0.090	Ω	$V_{GS} = 4.5V, I_D = 2.7A$ ②
			—	—	0.120		$V_{GS} = 2.5V, I_D = 2.2A$ ②
		P-Ch	—	—	0.135		$V_{GS} = -4.5V, I_D = -2.2A$ ②
			—	—	0.220		$V_{GS} = -2.5V, I_D = -1.7A$ ②
$V_{GS(th)}$	Gate Threshold Voltage	N-Ch	0.60	—	1.25	V	$V_{DS} = V_{GS}, I_D = 250\mu A$ $V_{DS} = V_{GS}, I_D = -250\mu A$
		P-Ch	-0.45	—	-1.2		$V_{DS} = 10V, I_D = 2.7A$ ② $V_{DS} = -10V, I_D = -2.2A$ ②
$g_{fs}$	Forward Transconductance	N-Ch	5.2	—	—	S	$V_{DS} = 16V, V_{GS} = 0V$
		P-Ch	3.5	—	—		$V_{DS} = -16V, V_{GS} = 0V$
$I_{DSS}$	Drain-to-Source Leakage Current	N-Ch	—	—	1.0	μA	$V_{DS} = 16V, V_{GS} = 0V$
		P-Ch	—	—	-1.0		$V_{DS} = -16V, V_{GS} = 0V$
		N-Ch	—	—	25		$V_{DS} = 16V, V_{GS} = 0V, T_J = 70^\circ\text{C}$
		P-Ch	—	—	-25		$V_{DS} = -16V, V_{GS} = 0V, T_J = 70^\circ\text{C}$
$I_{GSS}$	Gate-to-Source Forward Leakage	N-P	—	—	±100		$V_{GS} = \pm 12V$
$Q_g$	Total Gate Charge	N-Ch	—	4.0	6.0		N-Channel $I_D = 2.7A, V_{DS} = 10V, V_{GS} = 4.5V$ ②
		P-Ch	—	3.6	5.4		
$Q_{gs}$	Gate-to-Source Charge	N-Ch	—	0.95	—	nC	P-Channel $I_D = -2.2A, V_{DS} = -10V, V_{GS} = -4.5V$ ②
		P-Ch	—	0.66	—		
$Q_{gd}$	Gate-to-Drain ("Miller") Charge	N-Ch	—	0.83	—		N-Channel $V_{DD} = 10V, I_D = 1.0A, R_G = 6.2\Omega, V_{GS} = 4.5V$ ②
		P-Ch	—	5.7	—		
$t_{d(on)}$	Turn-On Delay Time	N-Ch	—	6.6	—	ns	P-Channel $V_{DD} = -10V, I_D = -1.0A, R_G = 6.0\Omega, V_{GS} = -4.5V$ ②
		P-Ch	—	8.3	—		
$t_r$	Rise Time	N-Ch	—	1.2	—		
		P-Ch	—	14	—		
$t_{d(off)}$	Turn-Off Delay Time	N-Ch	—	15	—		
		P-Ch	—	31	—		
$t_f$	Fall Time	N-Ch	—	2.4	—		
		P-Ch	—	28	—		
$C_{iss}$	Input Capacitance	N-Ch	—	400	—	pF	N-Channel $V_{GS} = 0V, V_{DS} = 15V, f = 1.0\text{MHz}$
		P-Ch	—	320	—		
$C_{oss}$	Output Capacitance	N-Ch	—	48	—		P-Channel $V_{GS} = 0V, V_{DS} = -15V, f = 1.0\text{MHz}$
		P-Ch	—	56	—		
$C_{rss}$	Reverse Transfer Capacitance	N-Ch	—	32	—		
		P-Ch	—	40	—		

## Source-Drain Ratings and Characteristics

Parameter	Description		Min.	Typ.	Max.	Units	Conditions
$I_S$	Continuous Source Current (Body Diode)	N-Ch	—	—	0.96	A	
		P-Ch	—	—	-0.96		
$I_{SM}$	Pulsed Source Current (Body Diode) ①	N-Ch	—	—	11		
		P-Ch	—	—	-9.0		
$V_{SD}$	Diode Forward Voltage	N-Ch	—	—	1.2	V	$T_J = 25^\circ\text{C}, I_S = 0.96A, V_{GS} = 0V$ ②
		P-Ch	—	—	-1.2		$T_J = 25^\circ\text{C}, I_S = -0.96A, V_{GS} = 0V$ ②
$t_{rr}$	Reverse Recovery Time	N-Ch	—	25	38	ns	N-Channel $T_J = 25^\circ\text{C}, I_F = 0.96A, di/dt = 100A/\mu s$
		P-Ch	—	23	35		
$Q_{rr}$	Reverse Recovery Charge	N-Ch	—	6.5	9.8	nC	P-Channel $T_J = 25^\circ\text{C}, I_F = -0.96A, di/dt = -100A/\mu s$ ②
		P-Ch	—	7.7	12		

### Notes:

- ① Repetitive rating; pulse width limited by max. junction temperature. ( See fig. 10 & 26 )  
② Pulse width  $\leq 400\mu s$ ; duty cycle  $\leq 2\%$ .

- ③ Surface mounted on FR-4 board,  $t \leq 10\text{sec}$ .

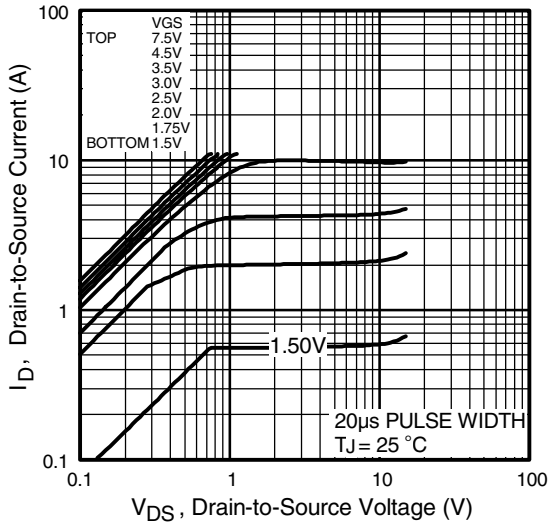

Fig 1. Typical Output Characteristics

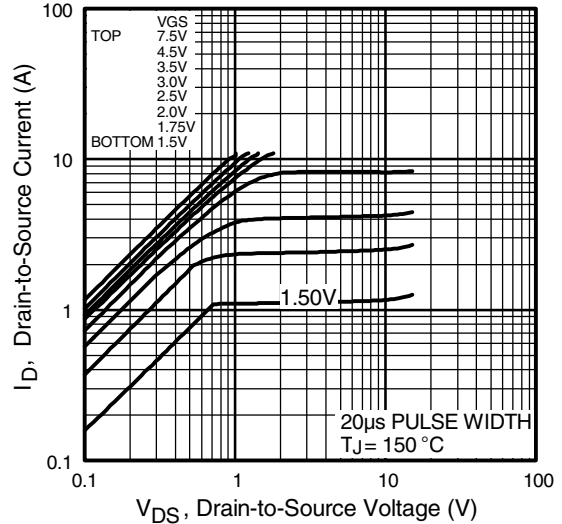

Fig 2. Typical Output Characteristics

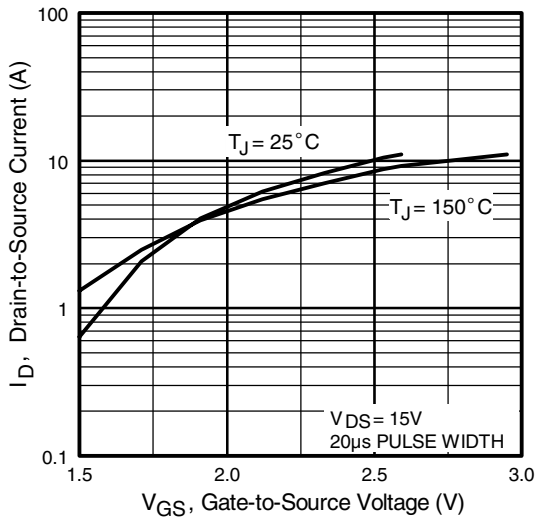

Fig 3. Typical Transfer Characteristics

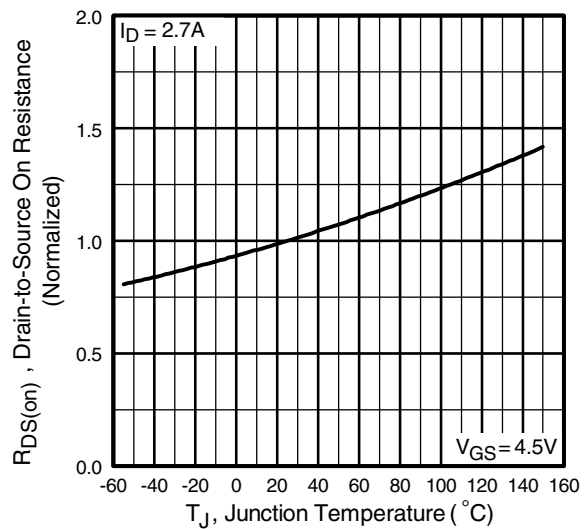
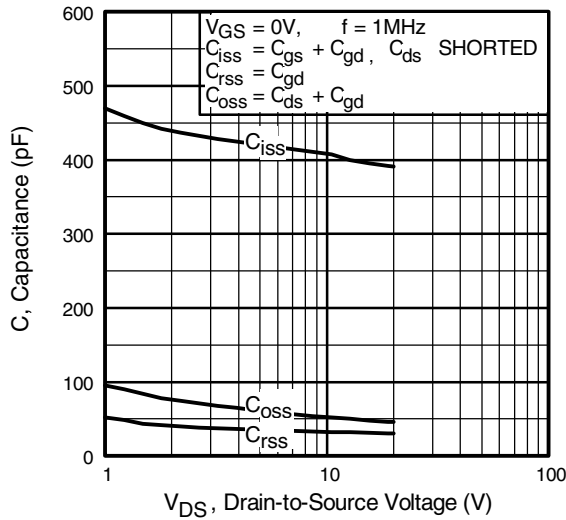
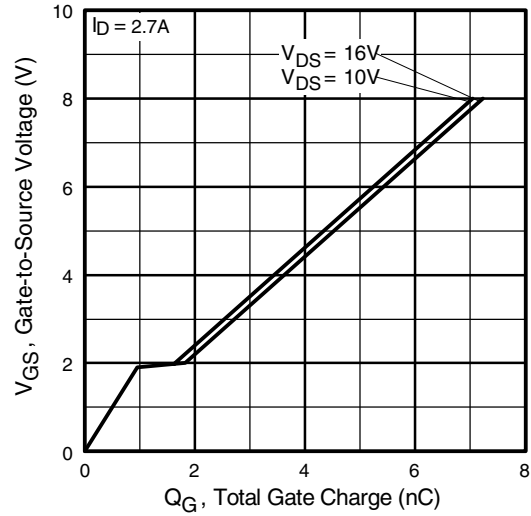

Fig 4. Normalized On-Resistance Vs. Temperature



**Fig 5.** Typical Capacitance Vs. Drain-to-Source Voltage



**Fig 6.** Typical Gate Charge Vs. Gate-to-Source Voltage

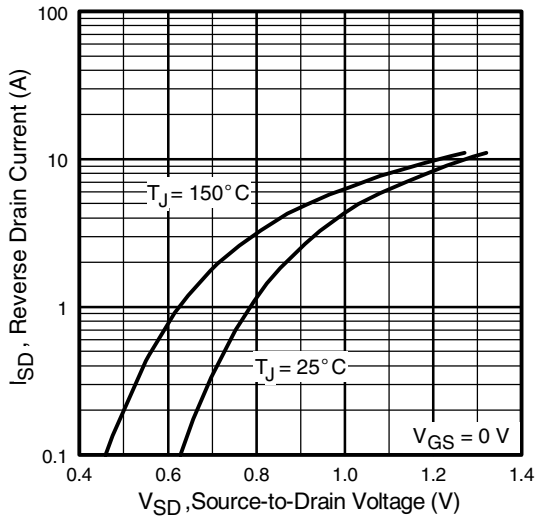

**Fig 7.** Typical Source-Drain Diode Forward Voltage

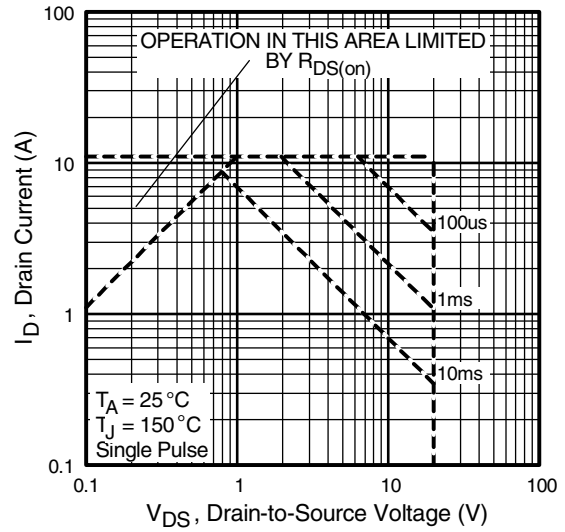

**Fig 8.** Maximum Safe Operating Area

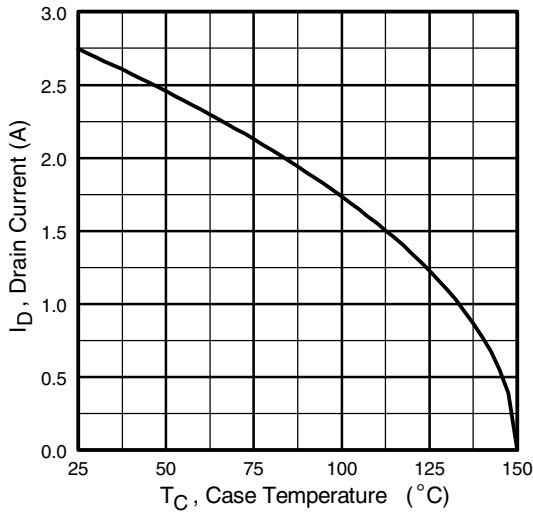

**Fig 9.** Maximum Drain Current Vs. Case Temperature

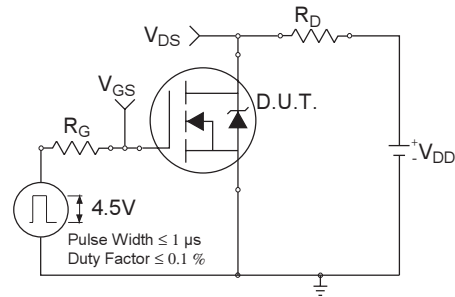

**Fig 10a.** Switching Time Test Circuit

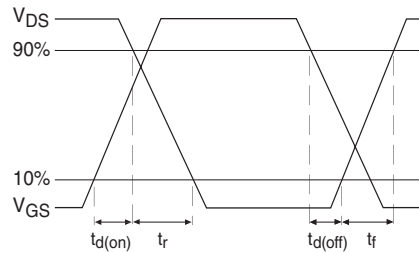

**Fig 10b.** Switching Time Waveforms

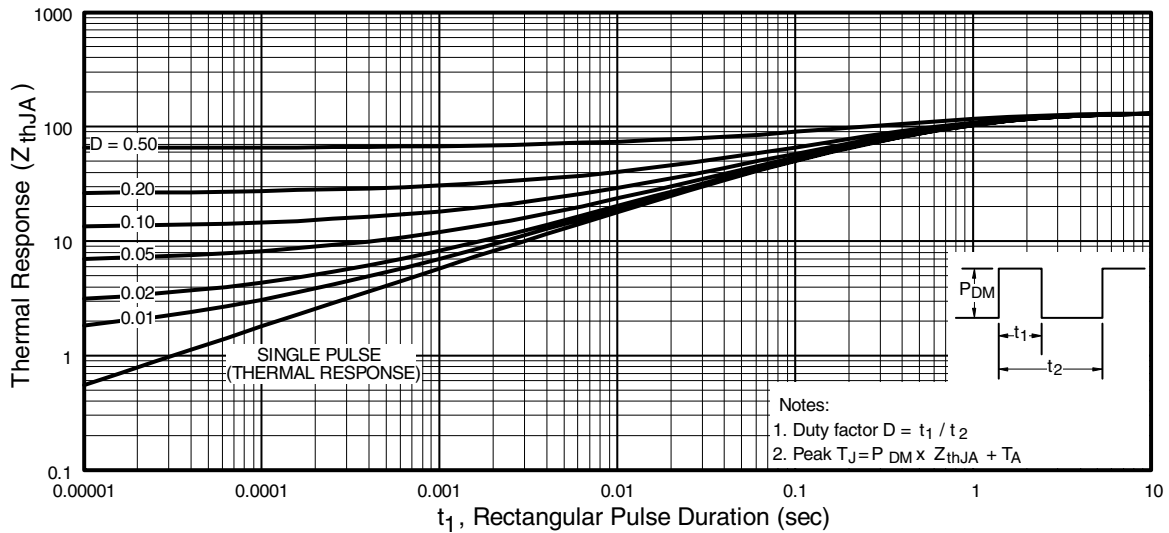
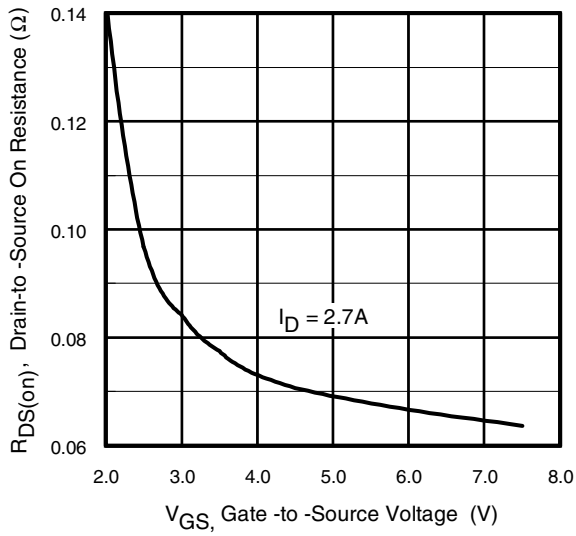

**Fig 10.** Typical Effective Transient Thermal Impedance, Junction-to-Ambient

# IRF5851

N-Channel

International  
**IR** Rectifier



**Fig 11.** Typical On-Resistance Vs. Gate Voltage

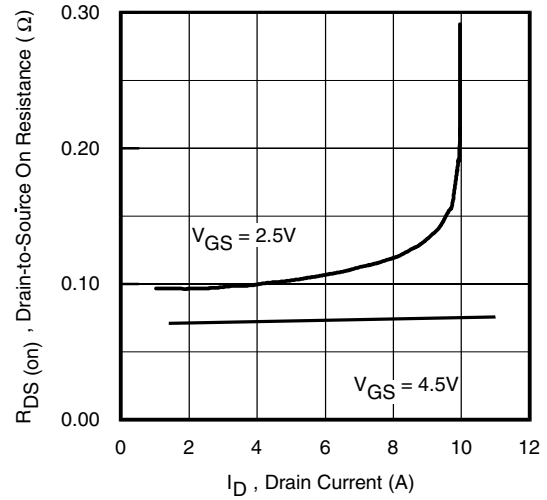

**Fig 12.** Typical On-Resistance Vs. Drain Current

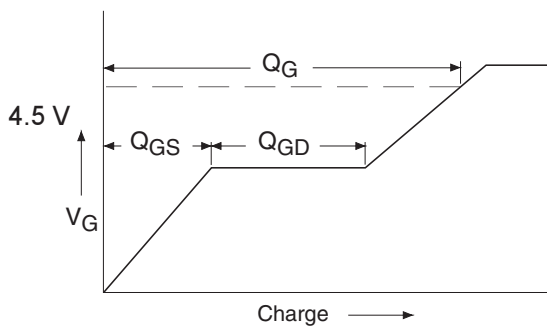

**Fig 13a.** Basic Gate Charge Waveform

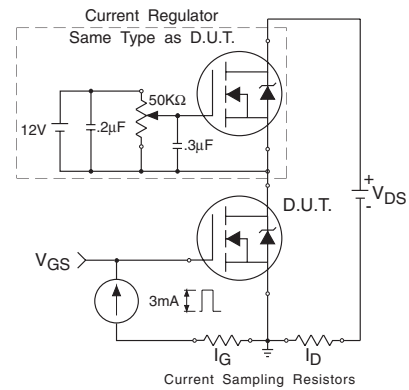

**Fig 13b.** Gate Charge Test Circuit

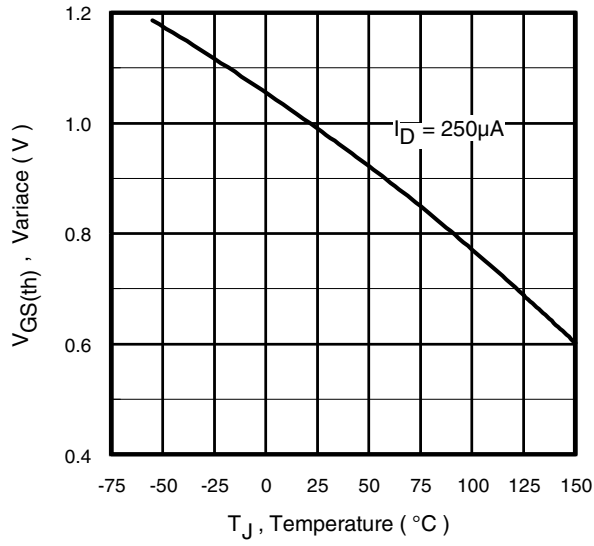

**Fig 14.** Threshold Voltage Vs. Temperature

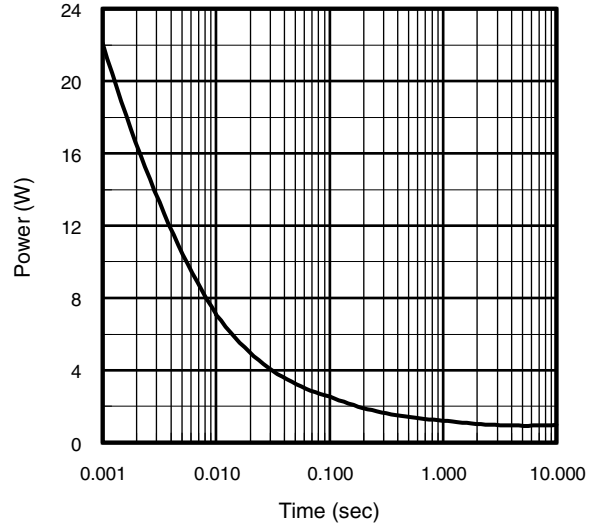

**Fig 15.** Typical Power Vs. Time

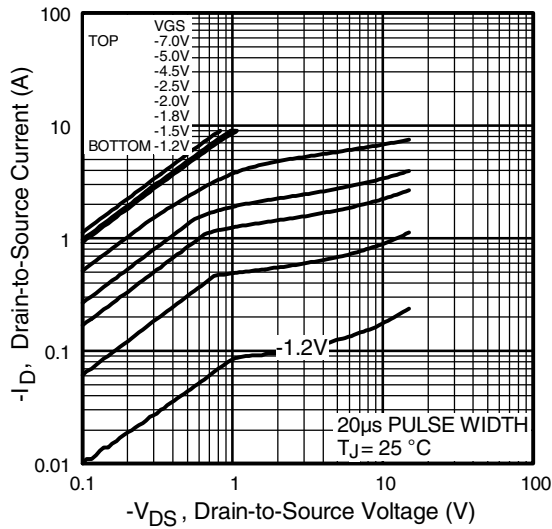

**Fig 16.** Typical Output Characteristics

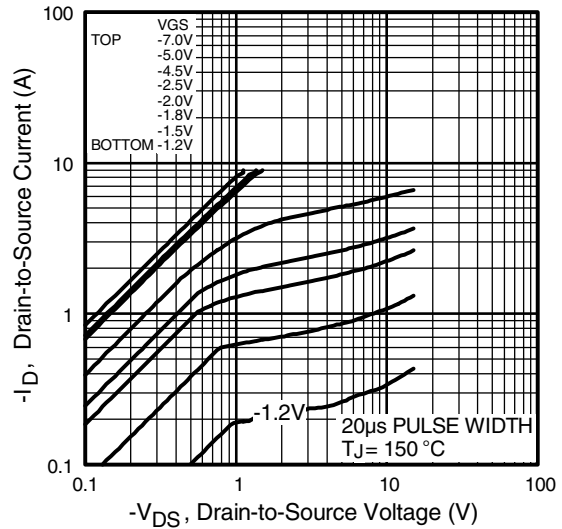

**Fig 17.** Typical Output Characteristics

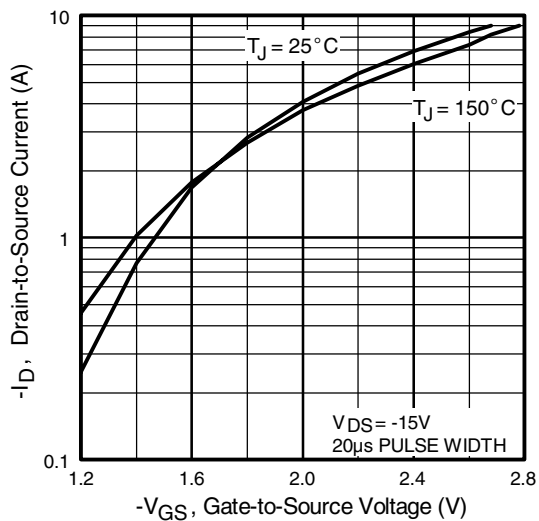

**Fig 18.** Typical Transfer Characteristics

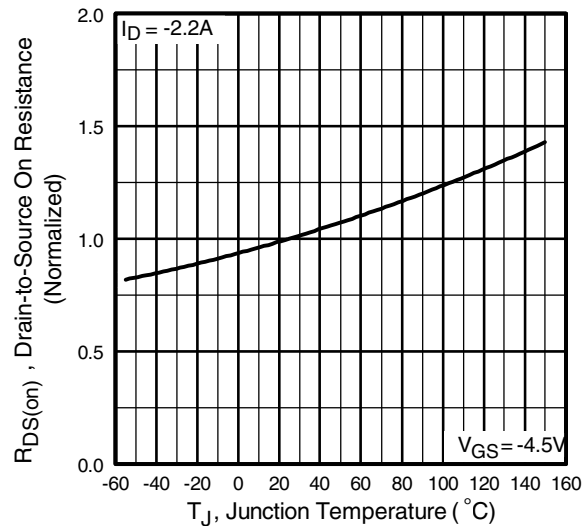

**Fig 19.** Normalized On-Resistance Vs. Temperature

P-Channel

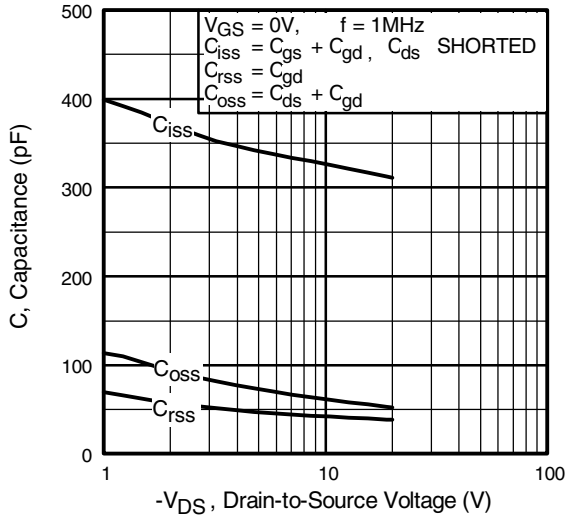

Fig 20. Typical Capacitance Vs. Drain-to-Source Voltage

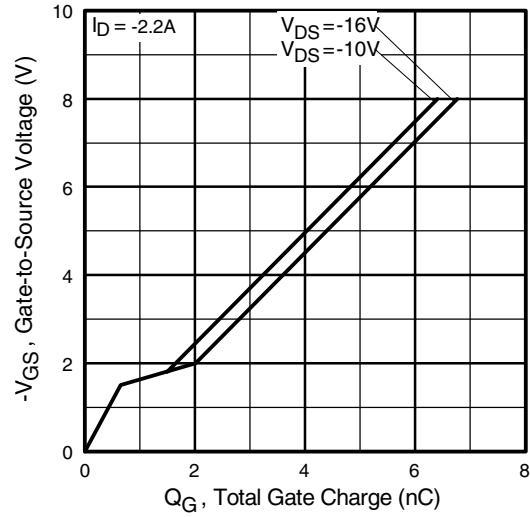

Fig 21. Typical Gate Charge Vs. Gate-to-Source Voltage

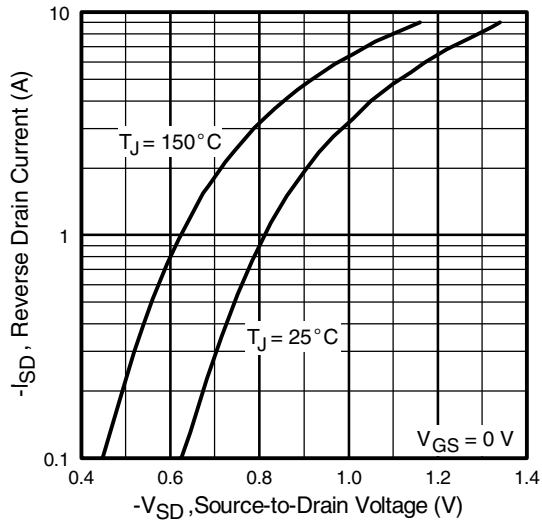

Fig 22. Typical Source-Drain Diode Forward Voltage

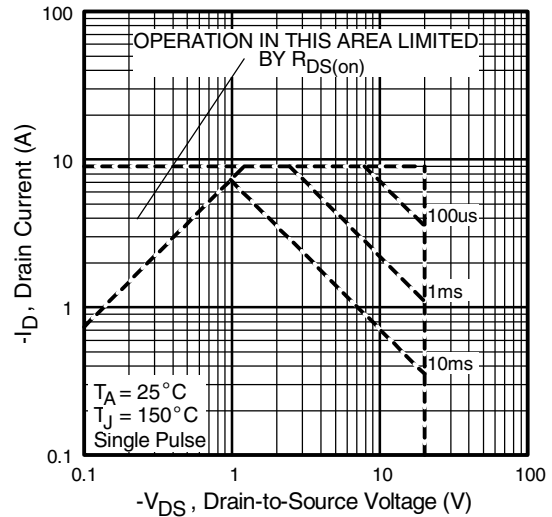
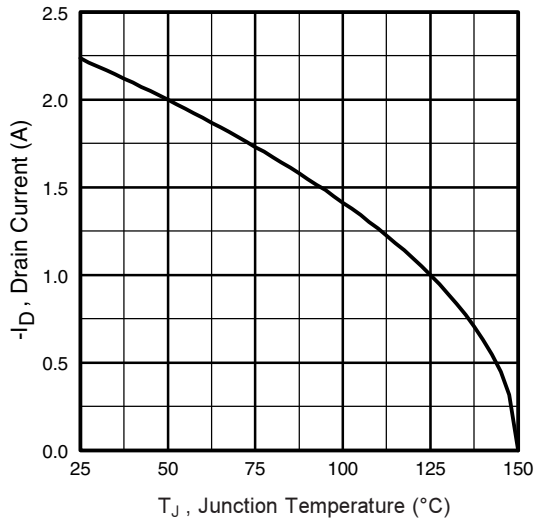

Fig 23. Maximum Safe Operating Area

# IRF5851

P-Channel

International  
**IR** Rectifier



**Fig 24.** Maximum Drain Current Vs. Junction Temperature

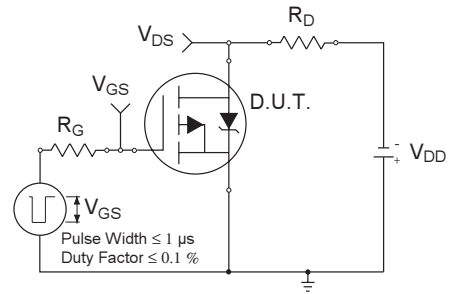

**Fig 25a.** Switching Time Test Circuit

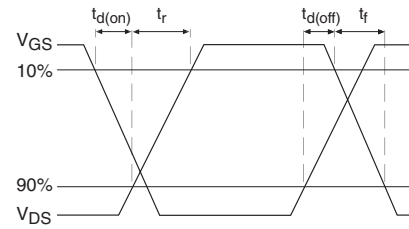

**Fig 25b.** Switching Time Waveforms

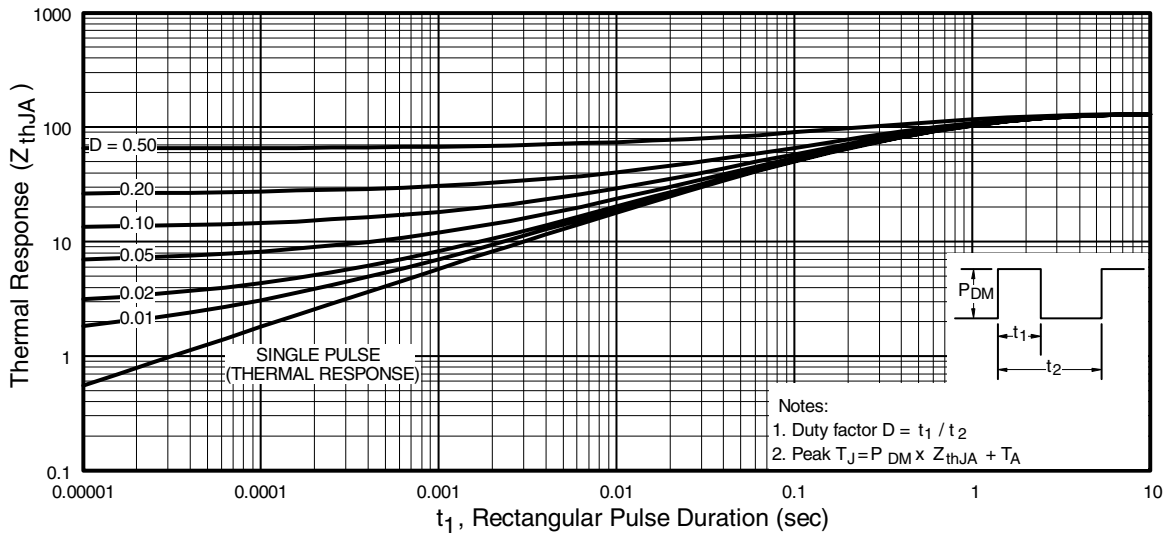

**Fig 26.** Typical Effective Transient Thermal Impedance, Junction-to-Ambient

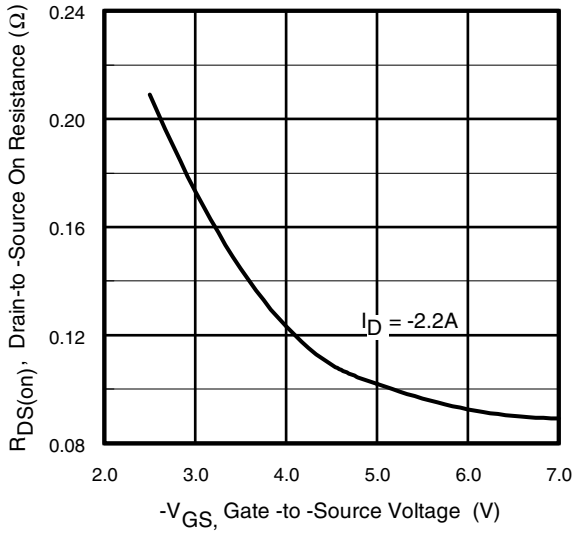

Fig 27. Typical On-Resistance Vs. Gate Voltage

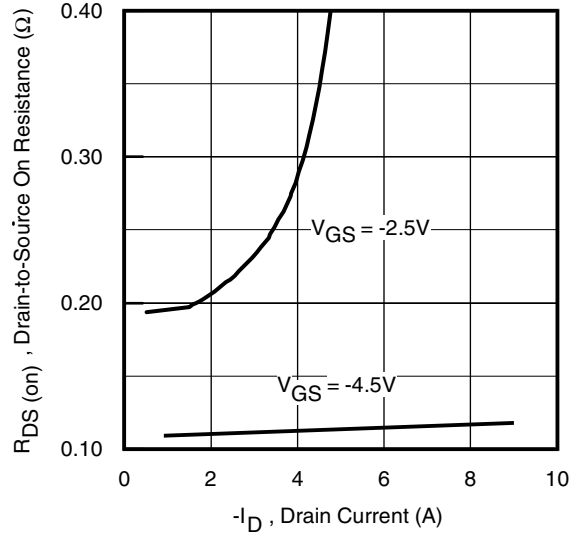

Fig 28. Typical On-Resistance Vs. Drain Current

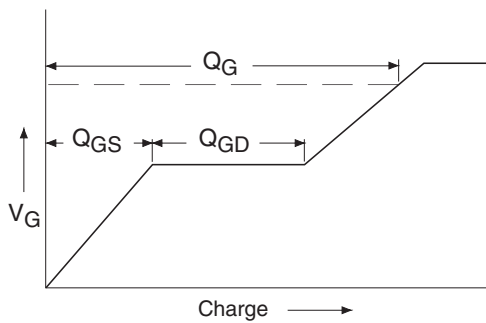

Fig 29a. Basic Gate Charge Waveform

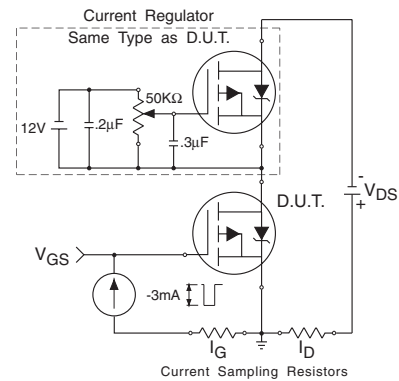

Fig 29b. Gate Charge Test Circuit

# IRF5851

P-Channel

International  
**IR** Rectifier

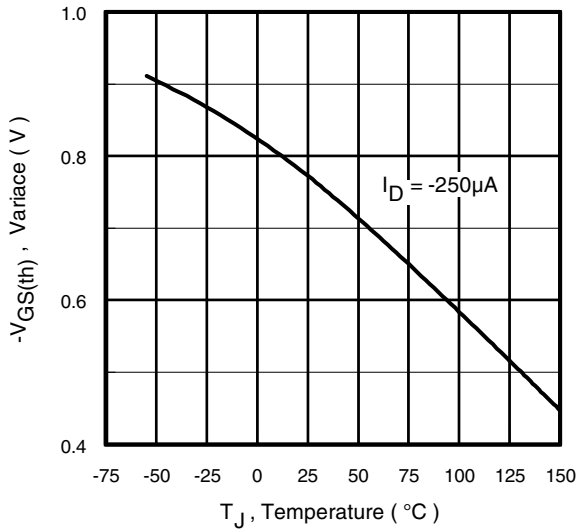

Fig 30. Threshold Voltage Vs. Temperature

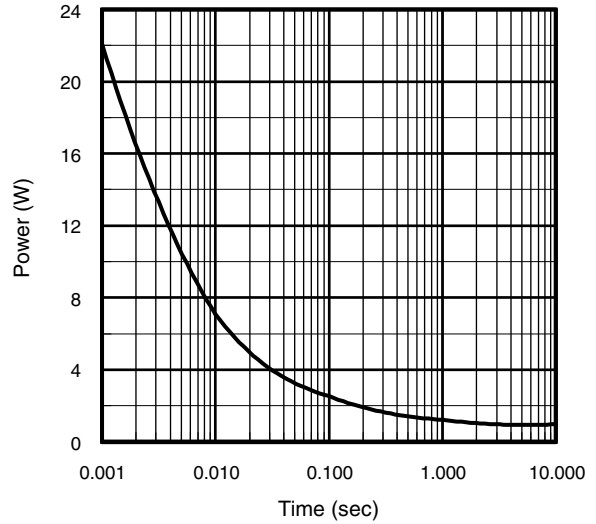
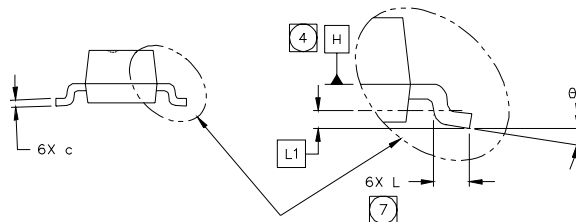
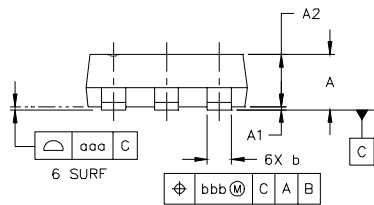
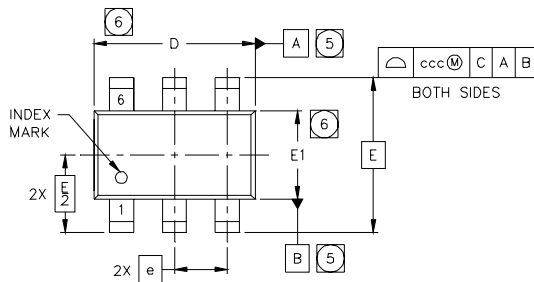

Fig 31. Typical Power Vs. Time

## TSOP-6 Package Outline



SYMBOL	MO-193AA DIMENSIONS					
	MILLIMETERS			INCHES		
	MIN	NOM	MAX	MIN	NOM	MAX
A	---	---	1.10	---	---	.0433
A1	0.01	---	0.10	.0004	---	.0039
A2	0.80	0.90	1.00	.0315	.0354	.0393
b	0.25	---	0.50	.0099	---	.0196
c	0.10	---	0.26	.004	---	.010
D	2.90	3.00	3.10	.115	.118	.122
E	2.75 BSC			.108 BSC		
E1	1.30	1.50	1.70	.052	.059	.066
e	1.00 BSC			.039 BSC		
L	0.20	0.40	0.60	.0079	.0157	.0236
L1	0.30 BSC			.0118 BSC		
θ	0°	---	8°	0°	---	8°
aaa	0.10			.004		
bbb	0.15			.006		
ccc	0.25			.010		

## TSOP-6 Part Marking Information (Old)

Note: This part marking information applies to devices produced before 02/26/2001.

EXAMPLE: THIS IS AN S13443DV WW = (1-26) IF PRECEDED BY LAST DIGIT OF CALENDAR YEAR

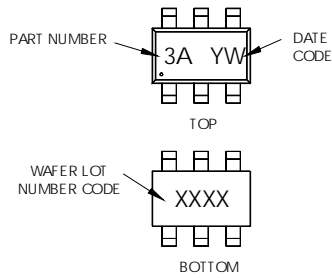

YEAR	Y	WORK WEEK	W
2001	1	01	A
2002	2	02	B
2003	3	03	C
2004	4	04	D
2005	5		
1996	6		
1997	7		
1998	8		
1999	9		
2000	0	24	X
		25	Y
		26	Z

PART NUMBER CODE REFERENCE:

3A = S13443DV  
 3B = IRF5800  
 3C = IRF5850  
 3D = IRF5851  
 3E = IRF5852  
 3I = IRF5805  
 3J = IRF5806

DATE CODE EXAMPLES:

YWW = 9603 = 6C  
 YWW = 9632 = FF

WW = (27-52) IF PRECEDED BY A LETTER

YEAR	Y	WORK WEEK	W
2001	A	27	A
2002	B	28	B
2003	C	29	C
2004	D	30	D
2005	E		
1996	F		
1997	G		
1998	H		
1999	J		
2000	K	50	X
		51	Y
		52	Z

## TSOP-6 Part Marking Information (New)

Note: This part marking information applies to devices produced after 02/26/2001.

W = (1-26) IF PRECEDED BY LAST DIGIT OF CALENDAR YEAR

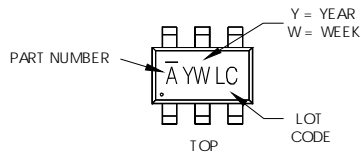

YEAR	Y	WORK WEEK	W
2001	1	01	A
2002	2	02	B
2003	3	03	C
2004	4	04	D
2005	5		
1996	6		
1997	7		
1998	8		
1999	9		
2000	0	24	X
		25	Y
		26	Z

PART NUMBER CODE REFERENCE:

A = S13443DV  
 B = IRF5800  
 C = IRF5850  
 D = IRF5851  
 E = IRF5852  
 I = IRF5805  
 J = IRF5806  
 K = IRF5810  
 L = IRF5804  
 M = IRF5803  
 N = IRF5820

W = (27-52) IF PRECEDED BY A LETTER

YEAR	Y	WORK WEEK	W
2001	A	27	A
2002	B	28	B
2003	C	29	C
2004	D	30	D
2005	E		
1996	F		
1997	G		
1998	H		
1999	J		
2000	K	50	X
		51	Y
		52	Z

# IRF5851

International  
**IR** Rectifier

## TSOP-6 Tape & Reel Information

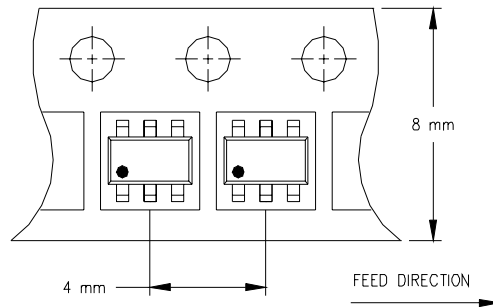

NOTES:

1. OUTLINE CONFORMS TO EIA-481 & EIA-541.

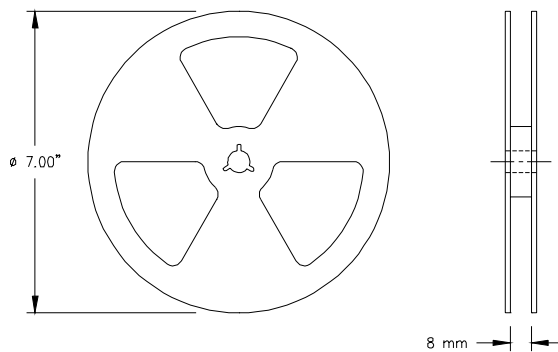

NOTES:

1. OUTLINE CONFORMS TO EIA-481 & EIA-541.

Data and specifications subject to change without notice.  
This product has been designed and qualified for the Industrial market.  
Qualification Standards can be found on IR's Web site.

International  
**IR** Rectifier

**IR WORLD HEADQUARTERS:** 233 Kansas St., El Segundo, California 90245, USA Tel: (310) 252-7105  
TAC Fax: (310) 252-7903

Visit us at [www.irf.com](http://www.irf.com) for sales contact information. 09/02



LittleDiode supplies new, hard to find or obsolete electronic components and semiconductors all over the world.

With over two million different components listed you are sure to find the part you need.

Feel free to visit us today at our online store:

[LittleDiode.com](http://LittleDiode.com)

Looking forward to providing you with the best possible service.