

FAIRCHILD

A Schlumberger Company

IRF150-153
N-Channel Power MOSFETs,
40 A, 60 V/100 V

Power And Discrete Division T-39-13

Description

These devices are n-channel, enhancement mode, power MOSFETs designed especially for high power, high speed applications, such as switching power supplies, UPS, AC and DC motor controls, relay and solenoid drivers and high energy pulse circuits.

TO-204AE

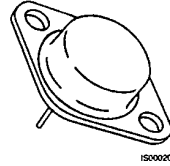

- Low $R_{DS(on)}$
- V_{GS} Rated at ± 20 V
- Silicon Gate for Fast Switching Speeds
- I_{DSS} , SOA Specified at Elevated Temperature
- Rugged
- Low Drive Requirements
- Ease of Paralleling

IRF150
 IRF151
 IRF152
 IRF153

2

Maximum Ratings

Symbol	Characteristic	Rating IRF150/152	Rating IRF151/153	Unit
V_{DSS}	Drain to Source Voltage ¹	100	60	V
V_{DGR}	Drain to Gate Voltage ¹ $R_{GS} = 20 \text{ k}\Omega$	100	60	V
V_{GS}	Gate to Source Voltage	± 20	± 20	V
T_J, T_{stg}	Operating Junction and Storage Temperatures	-55 to +150	-55 to +150	$^{\circ}\text{C}$
T_L	Maximum Lead Temperature for Soldering Purposes, 1/8" From Case for 5 s	275	275	$^{\circ}\text{C}$

Maximum On-State Characteristics

		IRF150/151	IRF152/153	
$R_{DS(on)}$	Static Drain-to-Source On Resistance ²	0.055	0.08	Ω
I_D	Drain Current			A
	Continuous	40	33	
	Pulsed	60	132	

Maximum Thermal Characteristics

$R_{\theta JC}$	Thermal Resistance, Junction to Case	0.83	0.83	$^{\circ}\text{C}/\text{W}$
P_D	Total Power Dissipation at $T_C = 25^{\circ}\text{C}$	150	150	W

Notes
 For information concerning connection diagram and package outline, refer to Section 7.

IRF150-153

T-39-13

Electrical Characteristics ($T_C = 25^\circ\text{C}$ unless otherwise noted)

Symbol	Characteristic	Min	Max	Unit	Test Conditions
Off Characteristics					
$V_{(BR)DSS}$	Drain Source Breakdown Voltage ¹			V	$V_{GS} = 0\text{ V}, I_D = 250\ \mu\text{A}$
	IRF150/152	100			
	IRF151/153	60			
I_{DSS}	Zero Gate Voltage Drain Current		250	μA	$V_{DS} = \text{Rated } V_{DSS}, V_{GS} = 0\text{ V}$
			1000	μA	$V_{DS} = 0.8 \times \text{Rated } V_{DSS}, V_{GS} = 0\text{ V}, T_C = 125^\circ\text{C}$
I_{GSS}	Gate-Body Leakage Current		± 100	nA	$V_{GS} = \pm 20\text{ V}, V_{DS} = 0\text{ V}$
On Characteristics					
$V_{GS(th)}$	Gate Threshold Voltage	2.0	4.0	V	$I_D = 250\ \mu\text{A}, V_{DS} = V_{GS}$
$R_{DS(on)}$	Static Drain-Source On-Resistance ²			Ω	$V_{GS} = 10\text{ V}, I_D = 20\text{ A}$
	IRF150/151		0.055		
	IRF152/153		0.08		
g_{fs}	Forward Transconductance	9.0		S (Ω)	$V_{DS} = 10\text{ V}, I_D = 20\text{ A}$
Dynamic Characteristics					
C_{iss}	Input Capacitance		3000	pF	$V_{DS} = 25\text{ V}, V_{GS} = 0\text{ V}$ $f = 1.0\text{ MHz}$
C_{oss}	Output Capacitance		1500	pF	
C_{rss}	Reverse Transfer Capacitance		500	pF	
Switching Characteristics ($T_C = 25^\circ\text{C}$, Figures 9, 10) ³					
$t_{d(on)}$	Turn-On Delay Time		35	ns	$V_{DD} = 24\text{ V}, I_D = 20\text{ A}$ $V_{GS} = 10\text{ V}, R_{GEN} = 4.7\ \Omega$ $R_{GS} = 4.7\ \Omega$
t_r	Rise Time		100	ns	
$t_{d(off)}$	Turn-Off Delay Time		125	ns	
t_f	Fall Time		100	ns	
$t_{d(on)}$	Turn-On Delay Time		75	ns	$V_{DD} = 75\text{ V}, I_D = 20\text{ A}$ $V_{GS} = 10\text{ V}, R_{GEN} = 50\ \Omega$ $R_{GS} = 50\ \Omega$
t_r	Rise Time		450	ns	
$t_{d(off)}$	Turn-Off Delay Time		300	ns	
t_f	Fall Time		200	ns	
Q_g	Total Gate Charge		120	nC	$V_{GS} = 10\text{ V}, I_D = 50\text{ A}$ $V_{DD} = 55\text{ V}$

Electrical Characteristics (Cont.) ($T_C = 25^\circ\text{C}$ unless otherwise noted)

Symbol	Characteristic	Typ	Max	Unit	Test Conditions
Source-Drain Diode Characteristics					
V_{SD}	Diode Forward Voltage IRF150/151	2.0	2.5	V	$I_S = 40\text{ A}; V_{GS} = 0\text{ V}$
	IRF152/153	2.0	2.3	V	$I_S = 33\text{ A}; V_{GS} = 0\text{ V}$
t_{rr}	Reverse Recovery Time	300		ns	$I_S = 4\text{ A}; di_S/dt = 25\text{ A}/\mu\text{S}$

Notes

- $T_J = +25^\circ\text{C}$ to $+150^\circ\text{C}$
- Pulse test: Pulse width $\leq 80\ \mu\text{s}$, Duty cycle $\leq 1\%$
- Switching time measurements performed on LEM TR-58 test equipment.

Typical Performance Curves

Figure 1 Output Characteristics

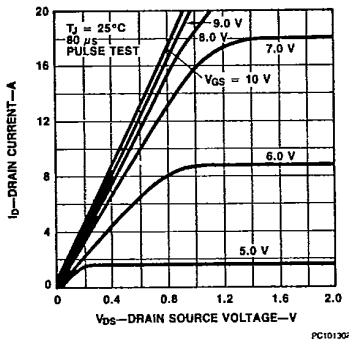

Figure 2 Static Drain to Source Resistance vs Drain Current

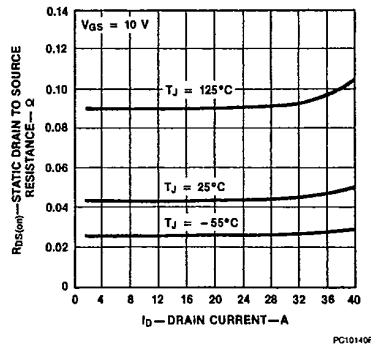

Figure 3 Transfer Characteristics

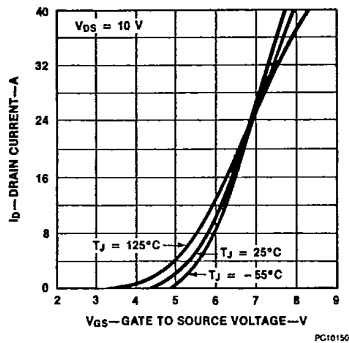
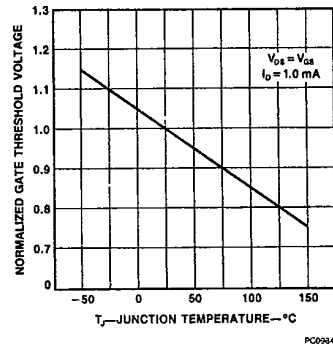

Figure 4 Temperature Variation of Gate to Source Threshold Voltage



Typical Performance Curves (Cont.)

Figure 5 Capacitance vs Drain to Source Voltage

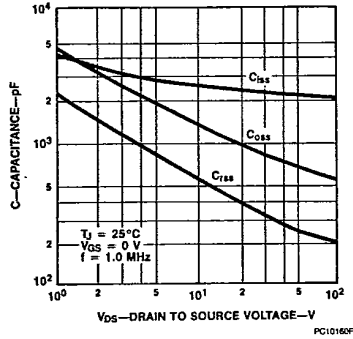

Figure 6 Gate to Source Voltage vs Total Gate Charge

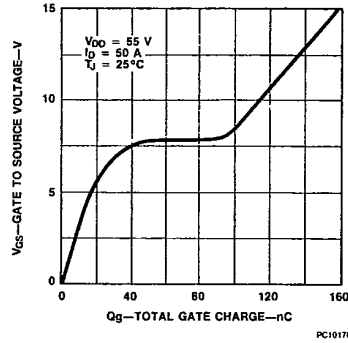

Figure 7 Forward Biased Safe Operating Area

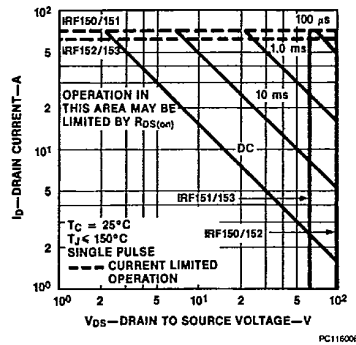
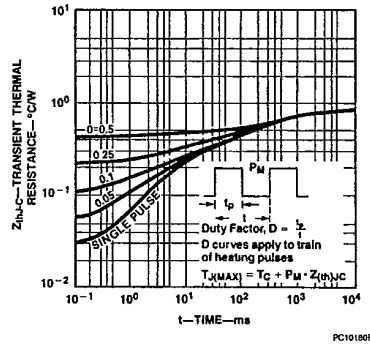

Figure 8 Transient Thermal Resistance vs Time



Typical Electrical Characteristics

Figure 9 Switching Test Circuit

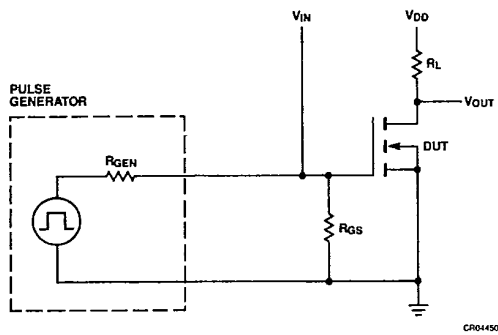
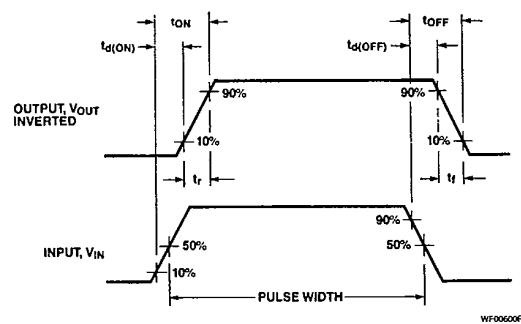

Figure 10 Switching Waveforms



This datasheet has been downloaded from:

www.DatasheetCatalog.com

Datasheets for electronic components.



LittleDiode supplies new, hard to find or obsolete electronic components and semiconductors all over the world.

With over two million different components listed you are sure to find the part you need.

Feel free to visit us today at our online store:

LittleDiode.com

Looking forward to providing you with the best possible service.