

FEATURES

Aperture Jitter of 20ps
Acquisition Time 25ns
Output Current $\pm 50\text{mA}$
Slew Rate $250\text{V}/\mu\text{s}$

APPLICATIONS

Data Acquisition Systems
Radar Systems
Instrumentation Systems
Medical Electronics
High Resolution Displays

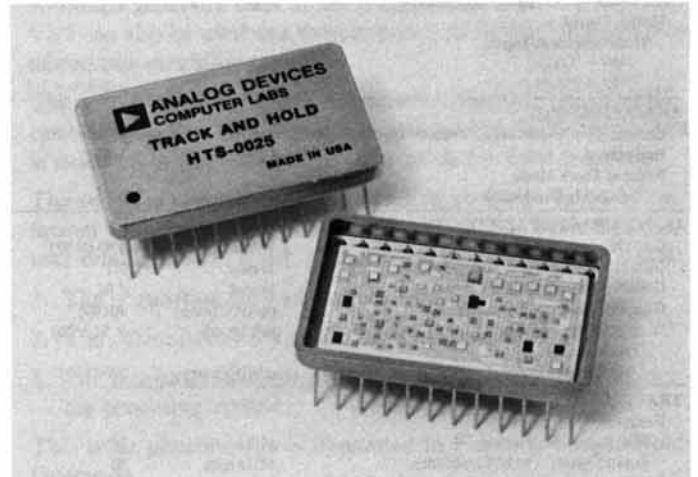

GENERAL DESCRIPTION

The Analog Devices HTS-0025 Track-and-Hold is another in Analog's range of track-and-hold (T/H) amplifiers useable in a variety of high-speed circuits. The HTS-0025 is part of a line of devices which offers designers the industry's widest range of track-and-hold and sample-and-hold units.

The design concepts used in the HTS-0025 T/H have made it the standard of comparison for high-speed circuits of this type. A dc-coupled Schottky diode bridge is driven by a high-impedance buffer amplifier and followed by a low impedance output amplifier. This achieves the best possible combination of speed and drive capabilities.

The pinouts of the HTS-0025 are similar to the HTS-0010 Track-and-Hold, so designers can select either the HTS-0025 or HTS-0010 for their particular applications. This kind of flexibility makes it possible to choose those parameters which are optimum for each application.

All models of the HTS-0025 are housed in a standard 24-pin metal DIP. The unit operating over a temperature range of 0 to $+70^\circ\text{C}$ is HTS-0025; the unit for a range of -55°C to $+100^\circ\text{C}$ is HTS-0025M; and the unit processed per MIL-STD 883, Method 5008, is HTS-0025MB.

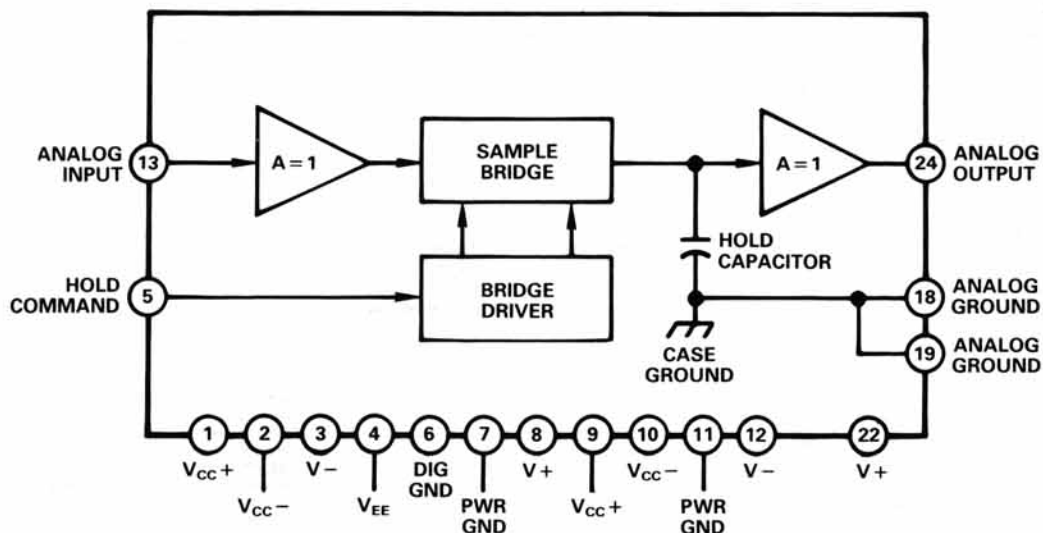

HTS-0025 Block Diagram

Information furnished by Analog Devices is believed to be accurate and reliable. However, no responsibility is assumed by Analog Devices for its use; nor for any infringements of patents or other rights of third parties which may result from its use. No license is granted by implication or otherwise under any patent or patent rights of Analog Devices.

Route 1 Industrial Park; P.O. Box 280; Norwood, Mass. 02062
Tel: 617/329-4700
West Coast 714/842-1717
Mid-West 312/653-5000
Texas 214/231-5094
TWX: 710/394-6577

SPECIFICATIONS (typical @ +25°C and nominal power supplies unless otherwise noted)

	Units	HTS-0025	HTS-0025M
ANALOG INPUT			
Voltage Range			
For Rated Performance	V p-p	2	*
Maximum Without Damage	V	±4	*
Impedance	Ω	10 ¹⁰	*
Capacitance	pF max	7	*
Bias Current	nA max	15	*
DIGITAL INPUT (ECL Compatible)			
Mode Control			
Hold Command Input			
"0" = Track	V	-1.5 to -1.8	*
"1" = Hold ¹	V	-0.8 to -1.1	*
ANALOG OUTPUT			
Current (Not Short Circuit Protected)	mA max	±50	*
Impedance	Ω(max)	3(10)	*
Noise in Track Mode			
@ 5.0MHz Bandwidth	mV rms max	0.1	*
DC ACCURACY/STABILITY (FS = Full Scale)			
Gain (No Load)	V/V (min)	0.95 (0.92)	*
Gain Nonlinearity; 2V FS Input	% max	0.1	*
Gain Nonlinearity; 1V FS Input	% max	0.01	*
Gain Temperature Coefficient	ppm/°C (max)	30 (40)	*
Output Offset Voltage	mV (max)	±5 (±20)	*
(Track Mode)			
vs. Temperature	μV/°C (max)	100 (150)	200 (300)
TRACK (SAMPLE) MODE DYNAMICS			
Frequency Response			
Full Power Bandwidth	MHz min	20	15
Small Signal (-3dB) Bandwidth	MHz min	30	20
Slew Rate	V/μs (min)	250 (140)	250 (120)
Harmonic Distortion (Track Mode;			
4MHz, 2V p-p Input)			
R _L = 1kΩ	dB max	-68	*
R _L = 500Ω	dB max	-65	*
R _L = 200Ω	dB max	-64	*
R _L = 75Ω	dB max	-50	*
TRACK (SAMPLE)-TO-HOLD SWITCHING			
Effective Aperture Delay Time ²	ns	5	*
Aperture Uncertainty (Jitter)	ps (rms) max	20	*
Offset Step (Pedestal)	mV (max)	±5 (±20)	*
Sensitivity to Temperature	μV/°C max	100	150 ³
Sensitivity to -5.2V	mV/V max	10	*
Switch Delay Time	ns	5	*
Switching Transient			
Amplitude	mV (max)	20 (25)	*
Settling to 5mV	ns (max)	20 (30)	*
HOLD MODE DYNAMICS			
Droop Rate	mV/μs (max)	0.2 (0.8)	*
Variation with Temperature		Doubles/10°C Change	
Feedthrough Rejection			
(2V p-p Input)			
@ 1MHz	dB min	70	*
@ 10MHz	dB min	65	*
HOLD-TO-TRACK (SAMPLE) DYNAMICS⁴			
Acquisition Time (1V Step)			
to ±1%	ns (max)	20 (30)	20 (40)
to ±0.1%	ns (max)	25 (35)	25 (40)
Acquisition Time (2V Step)			
to ±1%	ns (max)	25 (35)	25 (40)
to ±0.1%	ns (max)	30 (40)	30 (45)
Switch Delay Time	ns	1.5	*
POWER REQUIREMENTS			
V+ (+15V ±0.5V)	mA max	55	54
V- (-15V ±0.5V)	mA max	55	54
V _{CC} + (+5.0V to +15.5V) ⁵	mA max	15	*
V _{CC} - (-5.0V to -15.5V) ⁵	mA max	15	*
V _{EE} (-5.2V ±0.25V) ⁵	mA max	40	34
Power Dissipation ⁶	W max	2.3	2.4
Power Supply Rejection Ratio ⁷	mV/V max	18	*
(dc to 10kHz)			
TEMPERATURE RANGE			
Operating (Case)	°C	0 to +70	-55 to +100
Storage	°C	-55 to +125	*
THERMAL RESISTANCE⁸			
Junction to Air, θ _{ja} (Free Air)	°C/W	42	*
Junction to Case, θ _{jc}	°C/W	12	*
MTBF⁹			
Mean Time Between Failures	Hours		3.45 × 10 ⁵
PRICE			
1-24	\$	288	365
100s	\$	225	306

NOTES

¹One ECL 10k Gate, no resistor; requires 1kΩ to -5.2V

²Effective Aperture Delay Time is delay between

Hold strobe and held value of analog output, referenced to analog input (see text).

³Pedestal temperature variation on HTS-0025M is same as HTS-0025 below +70°C, but increases between +70°C and +100°C.

⁴For acquisition time measurements, R_L = 200Ω; C_L = 13pF.

⁵V_{CC}+ may be tied to V+; V_{CC}- may be tied to V- or V_{EE} with adequate bypass capacitors (see text).

⁶Maximum power shown based on V_{CC}+ = V+; V_{CC}- = V-. Power is reduced to 2.0W maximum with V_{CC}+ = +5V and V_{CC}- = -5V.

⁷Variations in V- (-15V) have greater effect on unit performance than variations in other supplies; PSRR shown is for V-.

⁸Maximum junction temperature is +150°C.

⁹Calculated using MIL-HNBK 217; Class B product to MIL-STD 883; Ground; Fixed; +25°C ambient temperature.

*Specifications same as HTS-0025.

Specifications subject to change without notice.

For applications assistance, call (919) 668-9511.

OUTLINE DIMENSIONS

Dimensions shown in inches and (mm).

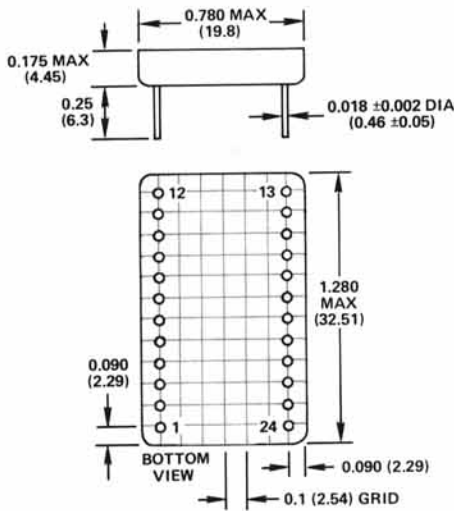

DOT ON TOP AND CERAMIC BEAD ON BOTTOM INDICATE POSITION OF PIN 1. PINS ARE GOLD PLATED.

PIN DESIGNATIONS

PIN	FUNCTION
1	V_{CC+} (+5V TO +15.5V)
2	V_{CC-} (-5V TO -15.5V)
3	$V-$ (-15V)
4	V_{EE} (-5.2V)
5	HOLD COMMAND
6	DIGITAL GROUND
7	POWER GROUND
8	$V+$ (+15V)
9	V_{CC+} (+5V TO +15.5V)
10	V_{CC-} (-5V TO -15.5V)
11	POWER GROUND
12	$V-$ (-15V)
13	ANALOG INPUT
14	N/A
15	N/A
16	N/A
17	N/A
18	ANALOG GROUND
19	ANALOG GROUND
20	N/A
21	N/A
22	$V+$ (+15V)
23	N/A
24	ANALOG OUTPUT

POWER GROUND (PINS 7 AND 11), ANALOG GROUND (PINS 18 AND 19), AND DIGITAL GROUND (PIN 6) MUST BE CONNECTED TOGETHER AND TO A LOW-IMPEDANCE GROUND FOR PROPER OPERATION. MAKE CONNECTIONS AS CLOSE TO DEVICE AS POSSIBLE. HYBRID CASE IS CONNECTED TO ANALOG GROUND INTERNALLY.

Applications

One of the main uses for Track-and-Hold (T/H) units is ahead of analog-to-digital (A/D) converters to allow digitizing signals with bandwidths higher than the A/D can handle by itself. The use of an appropriate T/H allows the converter to become a true "Nyquist converter", i.e., capable of digitizing analog signals whose maximum bandwidth is one-half the encoding rate.

The characteristics of the HTS-0025 T/H make it useful in multiple other applications besides this "standard" use of devices of this kind. It can be used in sample and hold circuits, peak holding applications, simultaneous sampling A/Ds (with appropriate analog multiplexing), and for many other data processing needs.

Refer to Figure 1, HTS-0025 Interconnection Diagram.

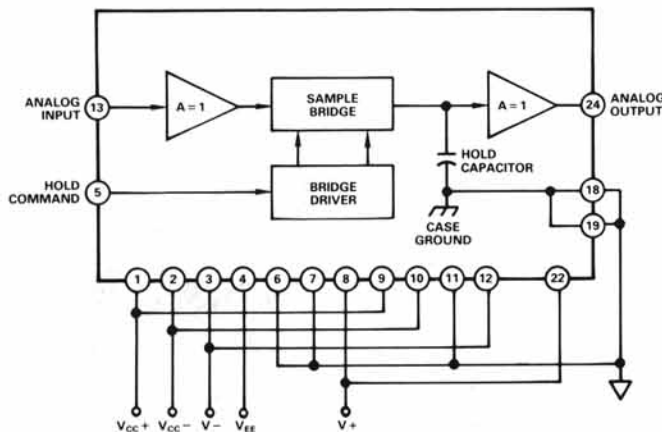

Figure 1. HTS-0025 Interconnection Diagram

Bypass capacitors are used internally on all power supply leads on the HTS-0025 Track-and-Hold. External bypassing of all power supplies with $0.01\mu\text{F}$ - $0.1\mu\text{F}$ ceramics will help performance. In addition, electrolytic capacitors of 10-22 microfarads on each supply will also enhance the HTS-0025's operation.

A massive ground plane, careful component layout, and physically separating analog and digital signals are among the other considerations which can have major effects in improving the high-speed characteristics of the HTS-0025 Track-and-Hold.

As shown, supply voltages must be applied to all pins for which they are designated; it is extremely important to connect all grounds together, and to a solid, low-impedance ground plane as close to the hybrid as physically possible.

The five different voltages shown are the voltages used in final test and calibration, and are the recommended voltages for best performance; minor variations are possible.

For best performance, amplifier supplies, V_{CC-} and V_{CC+} should be equal and opposite. The ECL logic supply ($V_{EE} = -5.2\text{V}$) can be used also for V_{CC-} ; if it is, bypass capacitors should be used at each supply pin to decrease the possibility of logic switching noise introducing extraneous signals.

TRACK-AND-HOLD MODE

When operated in the "track" mode, the HTS-0025 T/H functions as a buffer amplifier, following all changes in analog input as they occur. The user selects the point at which digitizing is to be done by applying an external ECL-compatible HOLD COMMAND to Pin 5.

Refer to Figure 2, Track/Hold Waveforms.

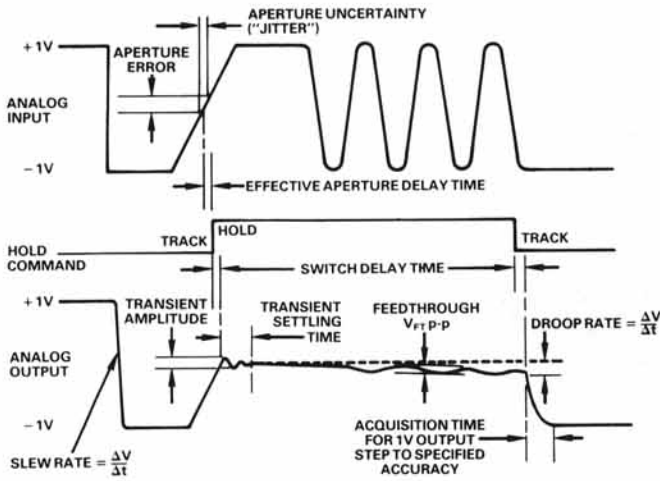

Figure 2. Track/Hold Waveforms

A varying, ideal analog input is shown at the top of Figure 2 for purposes of illustrating the response of the HTS-0025 to various types of inputs. This method of presentation shows many of the critical, and sometimes confusing, parameters of high-speed track-and-hold devices.

In the track mode, the response of the HTS-0025 is limited primarily by the slew rate characteristics of the device. As a result, the analog output is a faithful reproduction of the input as long as the highest frequency component of the input signal does not exceed the bandwidth of the unit.

The analog output shown on the bottom of Figure 2 tracks the input until a HOLD COMMAND is applied to Pin 5. When this pulse arrives, the sample bridge of the HTS-0025 disconnects the hold capacitor from the input. The short, but finite, interval required for this action is called aperture time (t_{sa}).

Other delay intervals combine with aperture time. One is delay

in the hold command caused by propagation delay in the bridge driver; for purposes of discussion, this is a digital delay because it is the time required for logic switching to occur. Another is propagation delay through the input buffer amplifier, which is an analog delay because it affects the analog input signal being applied to the hold capacitor (see HTS-0025 Block Diagram).

Each of these three components is critical in the design of track-and-hold circuits, but user concern is limited only to their combined effect. The combination is specified here as Effective Aperture Delay Time and is defined as the interval between the leading edge of the hold command and that instant when the input signal is equal to the held value.

Additional details on the timing intervals in T/H circuits are shown in Figure 3.

The model T/H shown at the top of Figure 3 contains the basic elements of the HTS-0025, shown in their simplest form. The lower portion of the figure calls out multiple intervals of incremental time involved in switching from "track" to "hold" but no attempt is made to assign numerical values to them. Their definitions are intended solely to help understand the theory of T/H operation.

Effective aperture delay time (t_e) is digital delay plus averaging of the switch delay, minus analog delay. Depending on the comparative lengths of these combined delays, the value of t_e can be zero, positive, or negative.

The specification for Effective Aperture Delay Time is a more useful measurement for assessing T/H performance than aperture time because it includes all three of the components which have an effect on how quickly the device can make the change from the track mode to the hold mode.

In normal operation, these time intervals become academic discussions since users of the T/H are more interested in when the held value has reached its steady state.

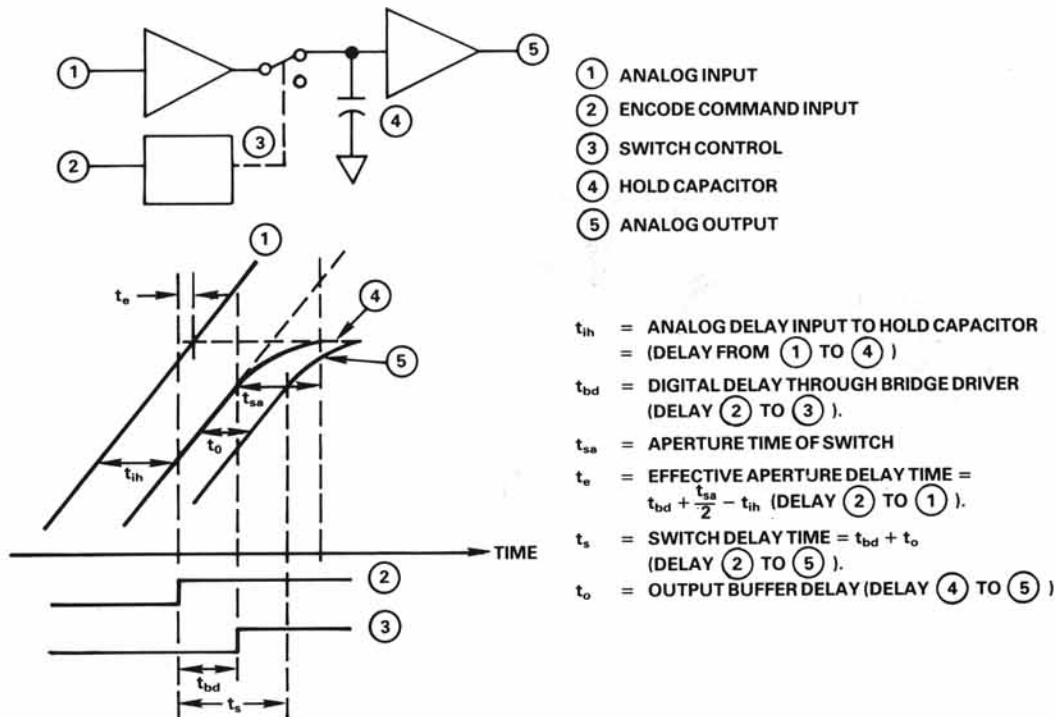

- ① ANALOG INPUT
- ② ENCODE COMMAND INPUT
- ③ SWITCH CONTROL
- ④ HOLD CAPACITOR
- ⑤ ANALOG OUTPUT

- t_{ih} = ANALOG DELAY INPUT TO HOLD CAPACITOR
= (DELAY FROM ① TO ④)
- t_{bd} = DIGITAL DELAY THROUGH BRIDGE DRIVER
(DELAY ② TO ③).
- t_{sa} = APERTURE TIME OF SWITCH
- t_e = EFFECTIVE APERTURE DELAY TIME =
 $t_{bd} + \frac{t_{sa}}{2} - t_{ih}$ (DELAY ② TO ①).
- t_s = SWITCH DELAY TIME = $t_{bd} + t_o$
(DELAY ② TO ⑤).
- t_o = OUTPUT BUFFER DELAY (DELAY ④ TO ⑤)

Figure 3. T/H Timing Intervals

The waveforms in Figure 3 are idealized and based on an analog input which has a constant dV/dt . Other phenomena which are involved, such as transients, "jitter," etc. are illustrated in Figure 2.

Aperture uncertainty, or "jitter," is the result of noise signals of various kinds which modulate the phase of the hold command. This jitter shows up as a sample-to-sample variation in the value of the analog signal which is being "frozen".

Aperture uncertainty manifests itself as an aperture error, as shown in Figure 2. The amplitude of the error is related to the dV/dt of the analog input. For any given value of aperture uncertainty, aperture error will increase as the input dV/dt increases.

The design of the HTS-0025 insures that effective aperture delay time is within its specification from unit to unit; and is also repeatable from one "hold" command to the next within any unit. Therefore, it should not be regarded as an error source the way aperture uncertainty is. Effective aperture delay time can be compensated with system timing which correctly establishes the beginning of the hold period.

A switching transient appears in the analog output as a result of the transition from "track" to "hold." The Specifications table includes the maximum amplitude and duration of this transient; and also includes information on the switch delay time which precedes it. The held output is settled to within 5mV 20-25ns after the leading edge of the hold signal.

Feedthrough rejection is a measure of the amount of leakage from input to output during the hold interval after the HTS-0025 has settled to its specified accuracy. High feedthrough rejection is important because it assures no errors will be introduced during the conversion interval of the converter used at the output of the T/H.

In the illustration, V_{FT} is the small amount of "ripple" voltage on the held value of analog output. The ratio of output feedthrough to input signal is measured in dB and is equal to:

$$20 \log \left[\frac{V_{FT} P-P}{V_{IN} P-P} \right]$$

As shown, droop is that amount of change in the analog output which occurs during the hold interval.

Switch delay time shown in Figure 2 is the interval between the edges of the hold command and the start of movements in the analog output. This delay occurs at both the beginning and the end of the hold interval and is primarily the result of propagation delay through the output buffer amplifier.

Acquisition time is the time required for the output of the T/H to reacquire and begin accurate tracking of the analog input after the T/H has returned to the "track" mode. The acquisition time "clock" starts when the output begins moving and stops when the output has settled to its specified accuracy. As might be expected, longer acquisition times are required for larger signals and/or greater accuracy.

High slew rates are also important during acquisition time, but the desire for speed must be tempered with practical consider-

ations. If the design of the unit achieves only speed without regard for overshoot, the acquisition time will be lengthened. Excessive "ringing" around the signal being acquired precludes applying successive hold commands at MHz update rates.

SAMPLE-AND-HOLD (S/H) MODE

Although generally used in the track-and-hold mode, the HTS-0025 can also be used as a sample-and-hold device for applications where this capability is needed.

The operation of the unit is essentially a "mirror" of the T/H operation, in that the output is usually in the "hold" mode but is switched to the "sample" (track) mode for brief intervals.

The width of the sample pulse which is used will be based on factors which are different for each application. Basically, the user establishes the width of this pulse by taking into account:

1. The acquisition time of the HTS-0025.
2. The desired accuracy of the sampled output.
3. The maximum amount of change which has occurred since the preceding sample.

This latter phenomenon is illustrated in Figure 4 Sample/Hold Operation.

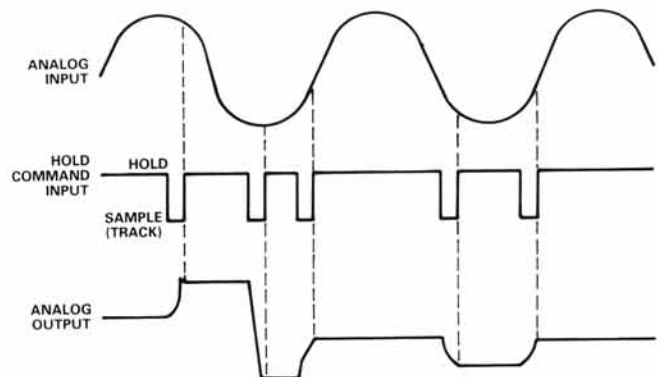

Figure 4. Sample/Hold Operation

When operating as a S/H, the signal applied to the HOLD COMMAND input (Pin 5) is usually a digital logic "1" which holds the HTS-0025 output at the input value present at the time of the sample/hold pulse.

Figure 4 shows asynchronous pulses applied to cause the output to reslew to new values. The trailing edge establishes the sample (track) mode; the leading edge returns the output to "hold".

In Figure 4, the analog input applied to the unit has changed drastically between the first and second sample (track) pulses. Smaller differences in the input values are present at the times of the second and third pulses. These differences in input show up as differences in the amount of movement of the analog output.

The acquisition time of the HTS-0025 makes it extremely attractive for sample-and-hold applications because of its ability to acquire new output values quickly. This characteristic of the device allows the use of a narrow sample pulse and an inherently faster sample rate, limited only by the factors enumerated earlier.

Refer to Figure 5 Settling Accuracy vs. Acquisition Time.

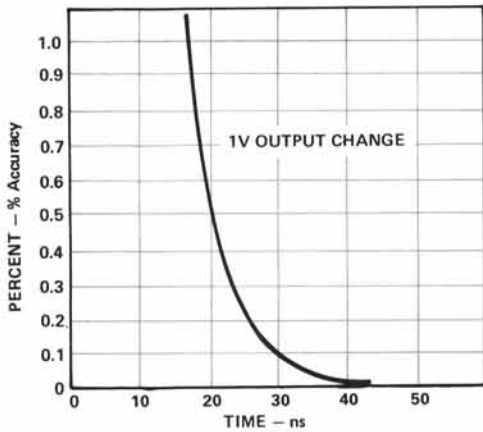

Figure 5. Settling Accuracy vs. Acquisition Time

This graph illustrates that closer accuracies require correspondingly longer amounts of time to acquire the signal. As shown, the accuracy/time relationship approaches an asymptotic curve, rather than being a linear function.

Another point to consider in Figure 5 is the illustrated output change is for a 1V change. If the output is required to change less than one volt (as it is between the second and third pulses

in Figure 4, for example), the amount of time required to acquire the new value will be less than that shown.

When using the HTS-0025 or any other high-speed track-and-hold in the real world of data acquisition for fast-changing signals, the line between the device operating as a T/H or a S/H tends to "blur."

The designer using it as a T/H ahead of an A/D converter will generally vary the amount of "hold" time to obtain optimum operation for his particular application. When that performance is achieved, the HTS-0025 may, in the strictest sense of the word, be operating as a sample-and-hold. But it is useful to regard the two modes of operation separately when discussing the theory of operation of the unit.

ORDERING INFORMATION

All versions of the HTS-0025 track/hold are housed in 24-pin metal dual in-line hybrid packages. For commercial applications operating over a temperature range of 0 to +70°C, specify model HTS-0025. For a temperature range of -55°C to +100°C, specify model HTS-0025M. A temperature range of -55°C to +100°C and processing to MIL-STD-883, Method 5008, are available in the model HTS-0025MB.

Mating individual pin sockets are available from AMP. Knockout end type are part number 6-330808-0; open end type are 6-330808-3.

Typical HTS-0025 Operation

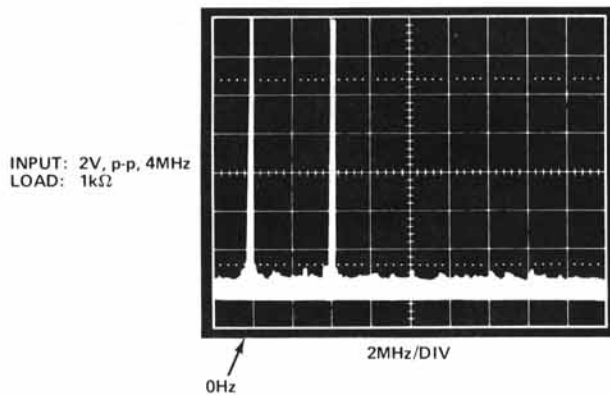

Figure 6a. Harmonic Distortion - Track Mode

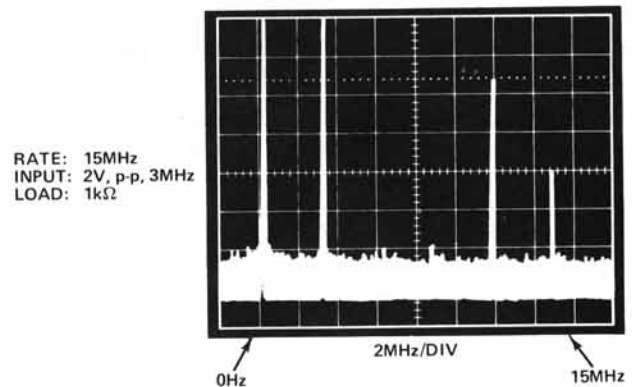

Figure 6b. Frequency Domain Outputs

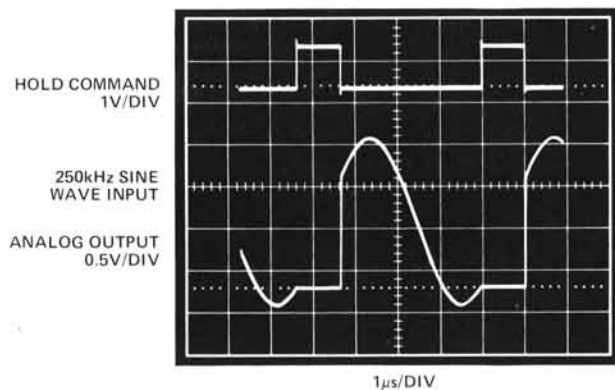

Figure 6c. Track/Hold Operation

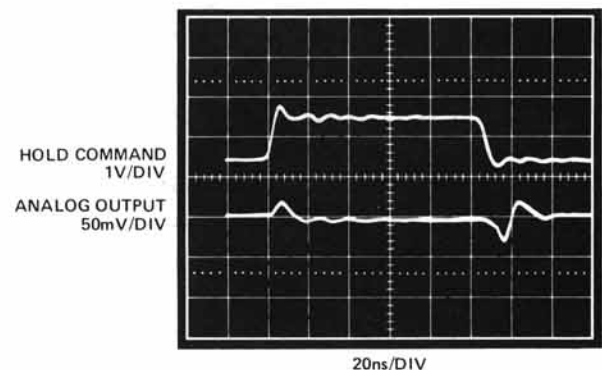

Figure 6d. Expanded View of Output Signal Showing Switching Transients and Pedestal with dc Input



LittleDiode supplies new, hard to find or obsolete electronic components and semiconductors all over the world.

With over two million different components listed you are sure to find the part you need.

Feel free to visit us today at our online store:

LittleDiode.com

Looking forward to providing you with the best possible service.