

T-1³/₄ (5 mm) High Performance TS AlGaAs Red LED Lamps

Technical Data

HLMP-810X Series HLMP-C100 HLMP-C110

Features

- Exceptional Brightness
- Outstanding LED Material Efficiency
- High Light Output Over a Wide Range of Drive Currents
- Viewing Angle: Narrow or Wide
- Low Forward Voltage
- Low Power Dissipation
- CMOS/MOS Compatible
- Red Color

Description

These T-1³/₄, untinted, nondiffused lamps utilize a highly optimized LED material technology, transparent substrate aluminum gallium arsenide (TS AlGaAs). This LED technology has a very high luminous efficiency, capable of producing high light output over a wide range of drive currents (500 μ A to 50 mA). The color is deep red at a dominant wavelength of 644 nm. TS AlGaAs is a flip-chip LED technology, die attached to the anode lead and wire bonded to the cathode lead.



Package Dimensions

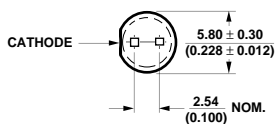
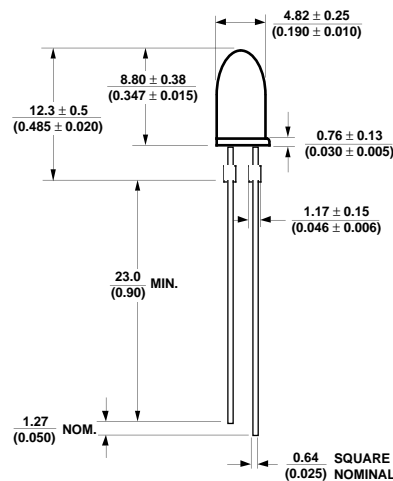

HLMP-8100

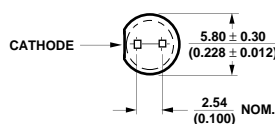
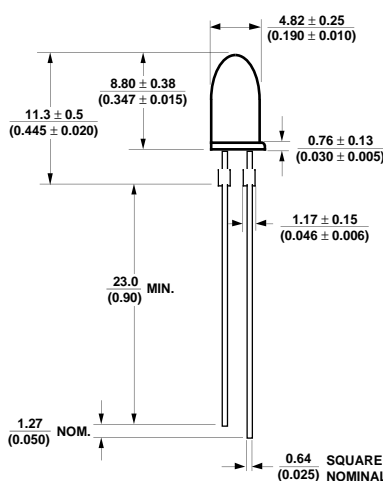

HLMP-8102/8103

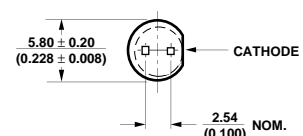
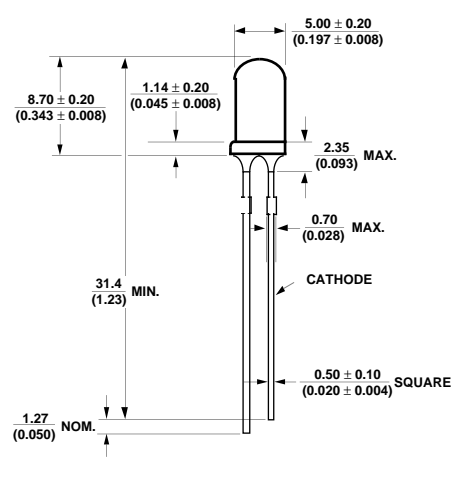

HLMP-C100/-C110

NOTES:
 1. ALL DIMENSIONS ARE IN MILLIMETERS/INCHES.
 2. THE LEADS ARE MILD STEEL, SOLDER DIPPED.
 3. AN EPOXY MENISCUS MAY EXTEND ABOUT 1 mm (0.040") DOWN THE LEADS, UNLESS OTHERWISE NOTED.

Axial Luminous Intensity and Viewing Angle at $T_A = 25^\circ\text{C}$

Part Number HLMP-	Minimum Intensity (mcd) @ 20 mA	Typical Intensity (mcd) @ 20 mA	Typical Radiant Intensity (mW/sr) @ 20 mA	$2\theta_{1/2}^{[1]}$ Degrees
8103	2000	3000	35.3	7
8102	1400	2000	23.5	7
8100	290	1000	11.8	19
C100	290	750	8.8	30
C110	200	400	4.7	40

Note:

1. $\theta_{1/2}$ is the off axis angle from optical centerline where the luminous intensity is 1/2 the on-axis value.

Absolute Maximum Ratings at $T_A = 25^\circ\text{C}$

Peak Forward Current ^[2]	300 mA
Average Forward Current (@ $I_{PEAK} = 300\text{ mA}$) ^[1,2]	30 mA
DC Forward Current ^[3]	50 mA
Power Dissipation	100 mW
Reverse Voltage ($I_R=100\ \mu\text{A}$)	5 V
Transient Forward Current (10 μs Pulse) ^[4]	500 mA
Operating Temperature Range	-55 to +100°C
Storage Temperature Range	-55 to +100°C
LED Junction Temperature	110°C
Lead Soldering Temperature	
[1.6 mm (0.063 in.) from body]	260°C for 5 seconds

Notes:

1. Maximum I_{AVG} at $f = 1\text{ kHz}$, $DF = 10\%$.
2. Refer to Figure 6 to establish pulsed operating conditions.
3. Derate linearly as shown in Figure 5.
4. The transient peak current is the maximum non-recurring peak current the device can withstand without damaging the LED die and wire bonds. It is not recommended that the device be operated at peak currents above the Absolute Maximum Peak Forward Current.

Electrical/Optical Characteristics at $T_A = 25^\circ\text{C}$

Description	Symbol	Min.	Typ.	Max.	Units	Test Conditions
Forward Voltage	V_F		1.85	2.4	V	$I_F = 20 \text{ mA}$
Reverse Voltage	V_R	5.0	20.0		V	$I_R = 100 \mu\text{A}$
Peak Wavelength	λ_{PEAK}		654		nm	
Dominant Wavelength ^[1]	λ_d		644		nm	
Spectral Line Halfwidth	$\Delta\lambda_{1/2}$		18		nm	
Speed of Response	τ_s		45		ns	Exponential Time Constant, $e^{-t/\tau}$
Capacitance	C		20		pF	$V_F = 0, f = 1 \text{ MHz}$
Thermal Resistance HLMP-810X	$R\theta_{\text{J-PIN}}$		210		$^\circ\text{C/W}$	Junction-to-Anode Lead
HLMP-C1X0			237			
Luminous Efficacy ^[2]	η_v		85		lm/W	

Notes:

1. The dominant wavelength, λ_d , is derived from the CIE chromaticity diagram and represents the color of the device.
2. The radiant intensity, I_e , in watts per steradian, may be found from the equation $I_e = I_v / \eta_v$, where I_v is the luminous intensity in candelas and η_v is luminous efficacy in lumens/watt

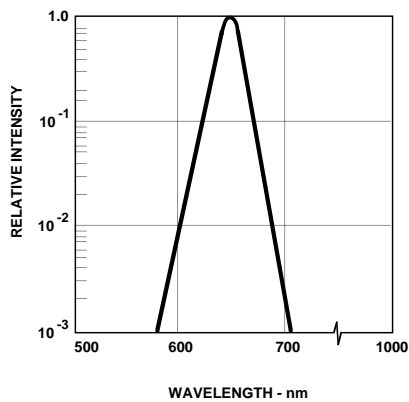

Figure 1. Relative Intensity vs. Wavelength.

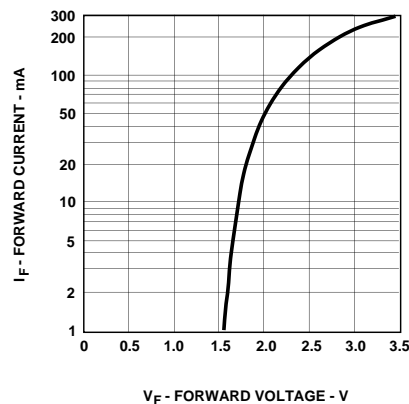

Figure 2. Forward Current vs. Forward Voltage.

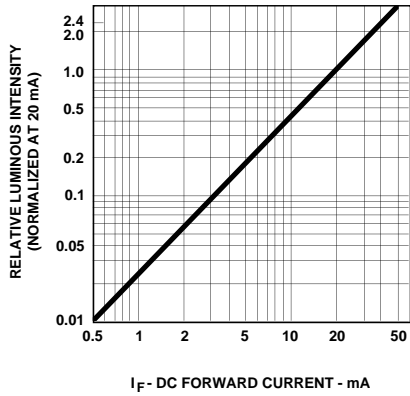

Figure 3. Relative Luminous Intensity vs. DC Forward Current.

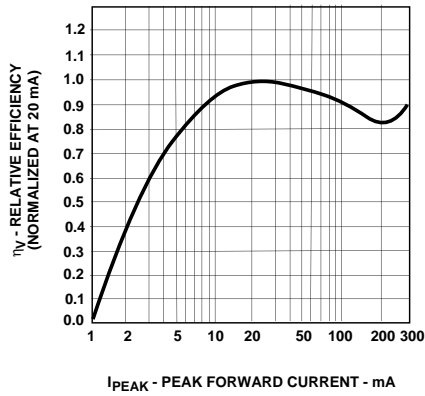

Figure 4. Relative Efficiency vs. Peak Forward Current.

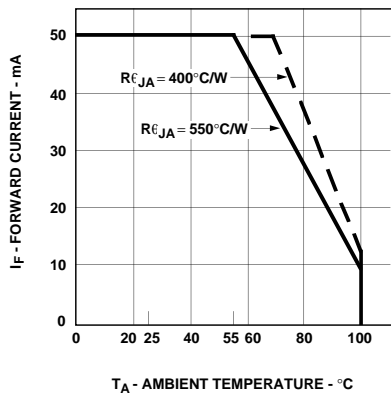

Figure 5. Maximum Forward DC Current vs. Ambient Temperature. Derating Based on $T_{JMAX} = 110^{\circ}C$.

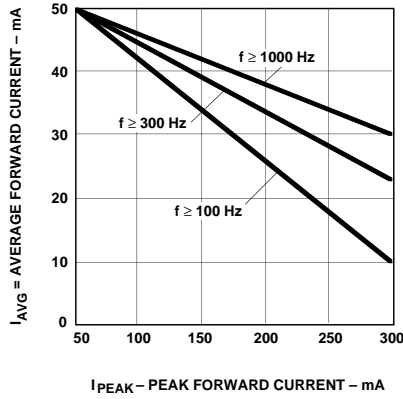

Figure 6. Maximum Average Current vs. Peak Forward Current.

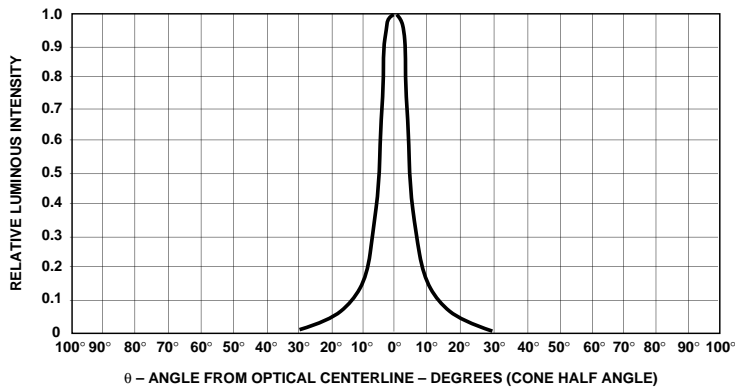

Figure 7. Relative Luminous Intensity vs. Angular Displacement. HLMP-8103 and HLMP-8102.

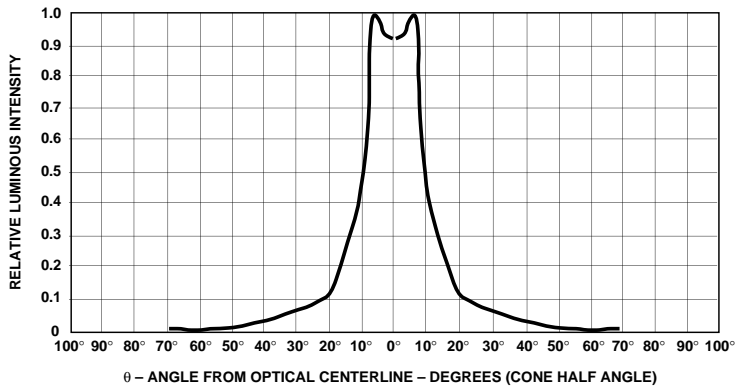

Figure 8. Relative Luminous Intensity vs. Angular Displacement. HLMP-8100.

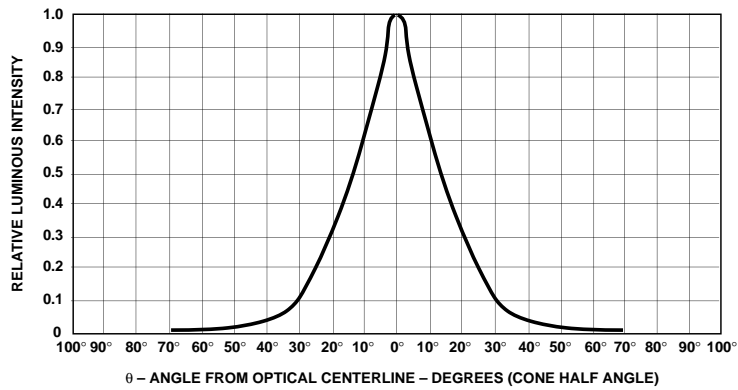

Figure 9. Relative Luminous Intensity vs. Angular Displacement. HLMP-C100.

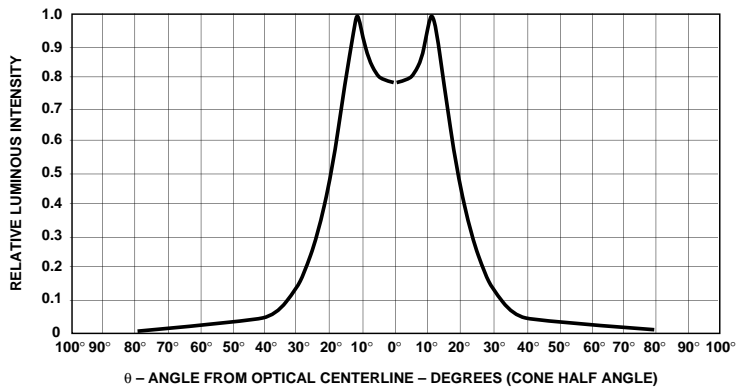

Figure 10. Relative Luminous Intensity vs. Angular Displacement. HLMP-C110.



LittleDiode supplies new, hard to find or obsolete electronic components and semiconductors all over the world.

With over two million different components listed you are sure to find the part you need.

Feel free to visit us today at our online store:

LittleDiode.com

Looking forward to providing you with the best possible service.