T-1³/₄ (5 mm), T-1 (3 mm), Ultra-Bright LED Lamps

Technical Data

HLMP-3707, -3807, -3907
HLMP-3750, -3850, -3950,
-3960
HLMP-3390, -3490, -3590
HLMP-1340, -1440, -1540
HLMP-D640
HLMP-K640

Features

- Improved Brightness
- Improved Color Performance
- Available in Popular T-1 and T-1³/₄ Packages
- New Sturdy Leads
- IC Compatible/Low Current Capability
- Reliable and Rugged
- Choice of 3 Bright Colors
High Efficiency Red
High Brightness Yellow
High Performance Green

Applications

- Lighted Switches
- Backlighting Front Panels
- Light Pipe Sources
- Keyboard Indicators

Description

These non-diffused lamps outperform conventional LED lamps. By utilizing new higher intensity material, we achieve superior product performance.

The HLMP-3750/-3390/-1340 Series Lamps are Gallium Arsenide Phosphide on Gallium Phosphide red light emitting diodes. The HLMP-3850/



-3490/-1440 Series are Gallium Arsenide Phosphide on Gallium Phosphide yellow light emitting diodes. The HLMP-3950/-3590/-3960/-1540/-D640/-K640 Series Lamps are Gallium Phosphide green light emitting diodes.

Selection Guide

Package Description	Color	Luminous Intensity Iv (mcd) @ 20mA				2 θ 1/2 Degree	Package Outline
		Device HLMP-	Min.	Typ.	Max.		
T-1 ^{3/4}	Red	3707-L00xx	90.2	-	-	24	F
		3750	90.2	125.0	-	24	A
		3750-L00xx	90.2	125.0	-	24	A
	Yellow	3807-K00xx	96.2	-	-	24	F
		3850	96.2	140.0	-	24	A
		3850-K00xx	96.2	140.0	-	24	A
		3850-KL0xx	96.2	150.0	294.0	24	A
	Green	3907-K00xx	111.7	-	-	24	F
		3914-K00xx	111.7	-	-	24	D
		3950	111.7	265.0	-	24	A
		3950-K00xx	111.7	265.0	-	24	A
		3950-LM0xx	170.0	300.0	490.0	24	A
		3960-K0xxx	111.7	265.0	-	24	E
	Emerald Green	D640-E00xx	6.7	21.0	-	24	D
	T-1 ^{3/4} Low Profile	Red	3390	35.2	55.0	-	32
	Yellow	3490	37.6	55.0	-	32	B
		3490-I00xx	37.6	55.0	-	32	B
	Green	3590	43.6	55.0	-	32	B
		3590-I00xx	43.6	55.0	-	32	B
T-1	Red	1340	35.2	55.0	-	45	C
		1340-H00xx	8.6	15.0	27.6	45	C
		1340-J00xx	35.2	55.0	-	45	C
		1340-JK0xx	35.2	55.0	112.8	45	C
	Yellow	1440	23.5	45.0	-	45	C
		1440-H00xx	23.5	45.0	-	45	C
		1440-HI0xx	23.5	-	75.2	45	C
		1440-HIB00	23.5	-	75.2	45	C
	Green	1540	27.3	45.0	-	45	C
		1540-H00xx	27.3	45.0	-	45	C
		1540-IJ0xx	43.6	60.0	139.6	45	C
	Emerald Green	K640	4.2	21.0	-	45	C
K640-D00xx		4.2	21.0	-	45	C	
K640-FGNxx		10.6	20.0	34.0	45	C	

Package Dimensions

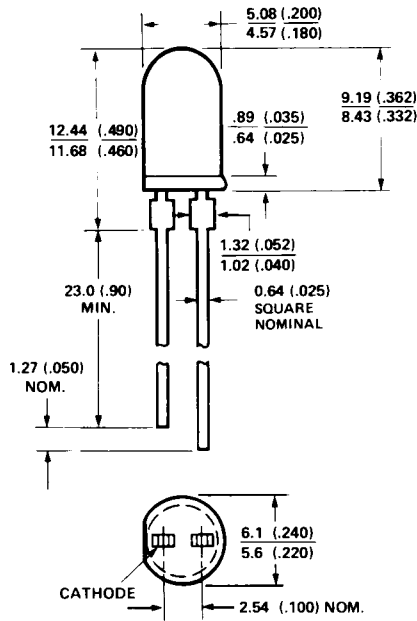

PACKAGE OUTLINE "A"
HLMP-3750, -3850, -3950

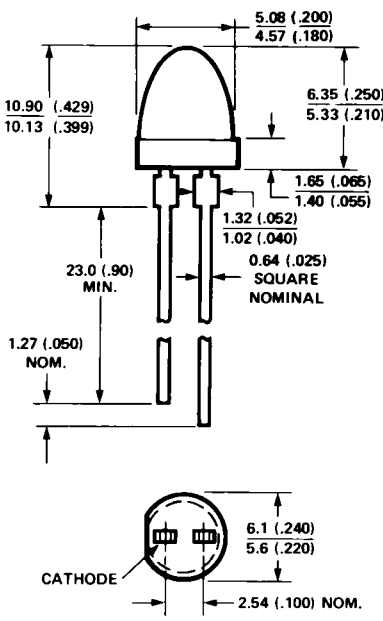

PACKAGE OUTLINE "B"
HLMP-3390, -3490, -3590

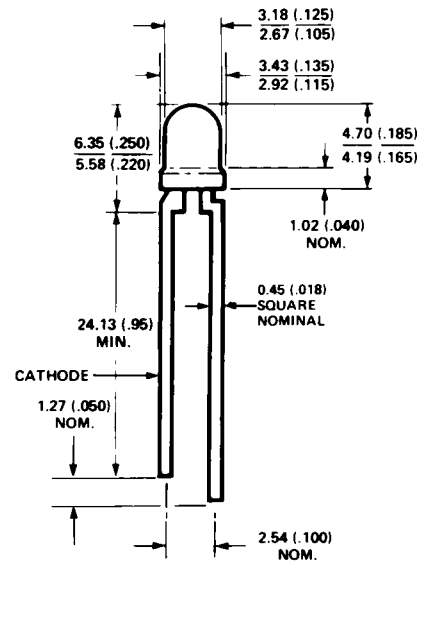

PACKAGE OUTLINE "C"
HLMP-1340, -1440, -1540

NOTES:
1. ALL DIMENSIONS ARE IN MILLIMETERS (INCHES).
2. AN EPOXY MENISCUS MAY EXTEND ABOUT 1 mm (0.040") DOWN THE LEADS.

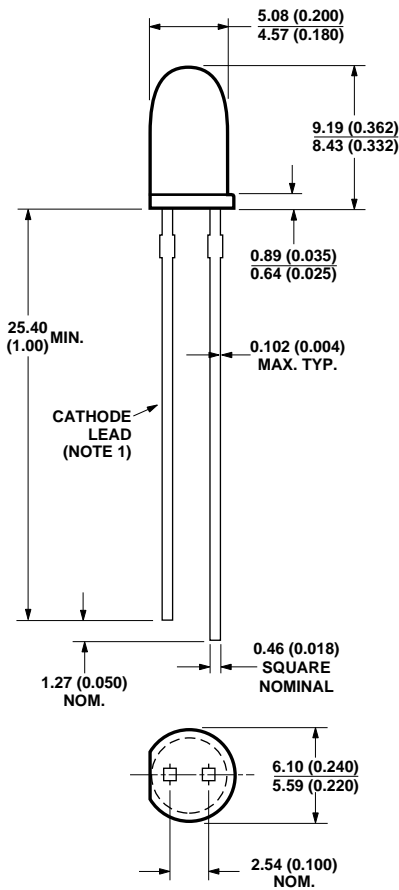

PACKAGE OUTLINE "D"
HLMP-D640

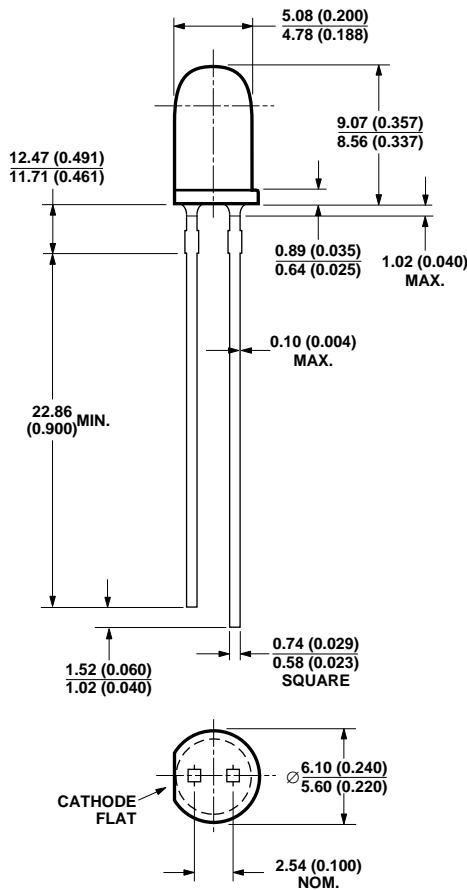

PACKAGE OUTLINE "E"
HLMP-3960

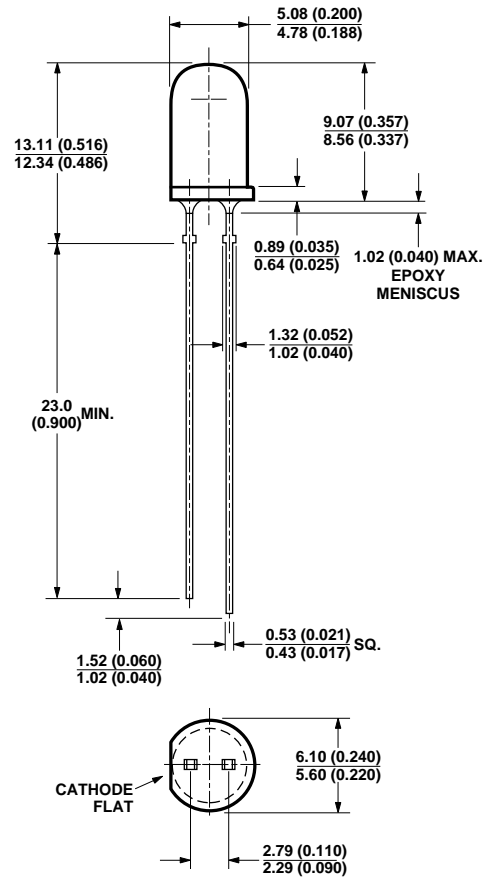

PACKAGE OUTLINE "F"
HLMP-3707/-3807/-3907

Part Numbering System

HLMP - x x xx - x x x xx

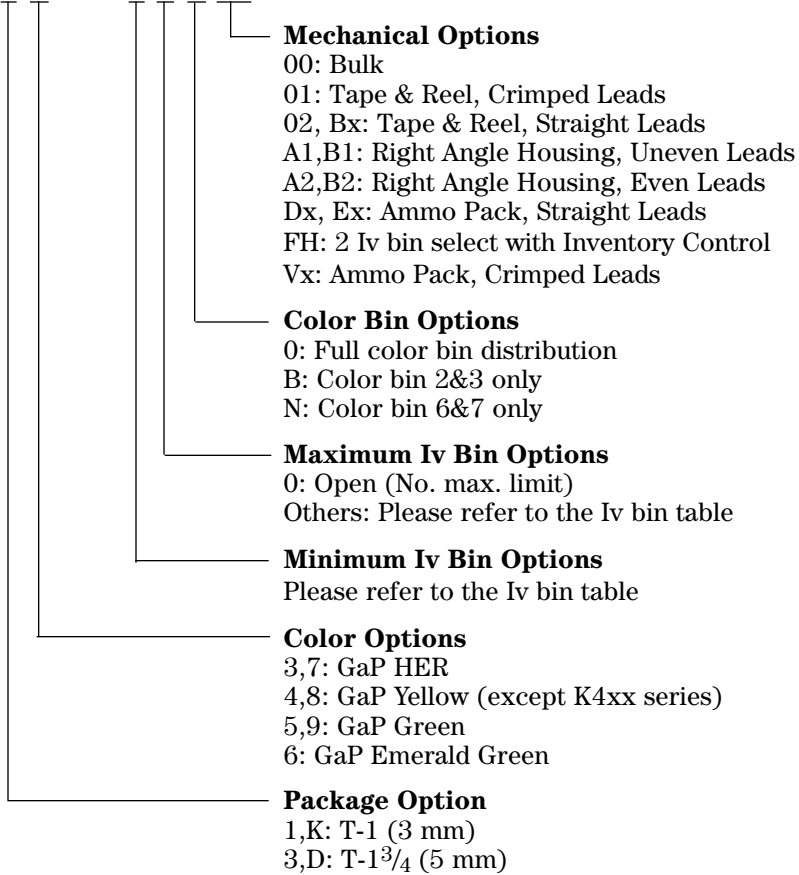

Absolute Maximum Ratings at $T_A = 25^\circ\text{C}$

Parameter	Red	Yellow	Green/Emerald Green	Units
Peak Forward Current	90	60	90	mA
Average Forward Current ^[1]	25	20	25	mA
DC Current ^[2]	30	20	30	mA
Transient Forward Current ^[3] (10 μs Pulse)	500	500	500	mA
Reverse Voltage ($I_R = 100 \mu\text{A}$)	5	5	5	V
LED Junction Temperature	110	110	110	$^\circ\text{C}$
Operating Temperature Range	-55 to +100	-55 to +100	-20 to +100	$^\circ\text{C}$
Storage Temperature Range			-55 to +100	
Lead Soldering Temperature [1.6 mm (0.063 in.) from body]	260 $^\circ\text{C}$ for 5 seconds			

Notes:

- See Figure 2 to establish pulsed operating conditions.
- For Red and Green series derate linearly from 50 $^\circ\text{C}$ at 0.5 mA/ $^\circ\text{C}$. For Yellow series derate linearly from 50 $^\circ\text{C}$ at 0.2 mA/ $^\circ\text{C}$.
- The transient peak current is the maximum non-recurring peak current the devices can withstand without damaging the LED die and wire bonds. It is not recommended that the device be operated at peak currents beyond the Absolute Maximum Peak Forward Current.

Electrical/Optical Characteristics at T_A = 25 °C

Symbol	Description	T-1 ^{3/4}	T-1 ^{3/4} Low Dome	T-1	Min.	Typ.	Max.	Units	Test Conditions
λ_{PEAK}	Peak Wavelength	37xx 38xx 39xx D640	3390 3490 3590	1340 1440 1540 K640		635 583 565 558		nm	Measurement at Peak
λ_d	Dominant Wavelength	37xx 38xx 39xx D640	3390 3490 3590	1340 1440 1540 K640		626 585 569 560		nm	Note 1
$\Delta\lambda^{3/4}$	Spectral Line Halfwidth	37xx 38xx 39xx D640	3390 3490 3590	1340 1440 1540 K640		40 36 28 24		nm	
τ_s	Speed of Respond	37xx 38xx 39xx D640	3390 3490 3590	1340 1440 1540 K640		90 90 500 3100		ns	
C	Capacitance	37xx 38xx 39xx D640	3390 3490 3590	1340 1440 1540 K640		11 15 18 35		pF	V _F = 0, f = 1 MHz
R θ_{J-PIN}	Thermal Resistance	37xx 38xx 39xx D640	3390 3490 3590	1340 1440 1540 K640		210 210 210 510 290 290 290 290		°C/W	Junction to Cathode Lead
V _F	Forward Voltage	37xx 38xx 39xx D640	3390 3490 3590	1340 1440 1540 K640	1.5 1.5 1.5	1.9 2.1 2.2 2.2	2.6 2.6 3.0 3.0	V	I _F = 20 mA (Figure 3)
V _R	Reverse Breakdown Voltage	37xx 38xx 39xx D640	3390 3490 3590	1340 1440 1540 K640	5.0			V	I _F = 100 μ A
η_v	Luminous Efficacy	37xx 38xx 39xx D640	3390 3490 3590	1340 1440 1540 K640		145 500 595 655		Lumens Watt	Note 2

Notes:

- The dominant wavelength, λ_d , is derived from the CIE chromaticity diagram and represents the single wavelength which defines the color of the device.
- The radiant intensity, I_e , in watts per steradian, may be found from the equation $I_e = IV/h\nu$, where IV is the luminous intensity in candelas and $h\nu$ is the luminous efficacy in lumens/watt.

Red, Yellow, and Green

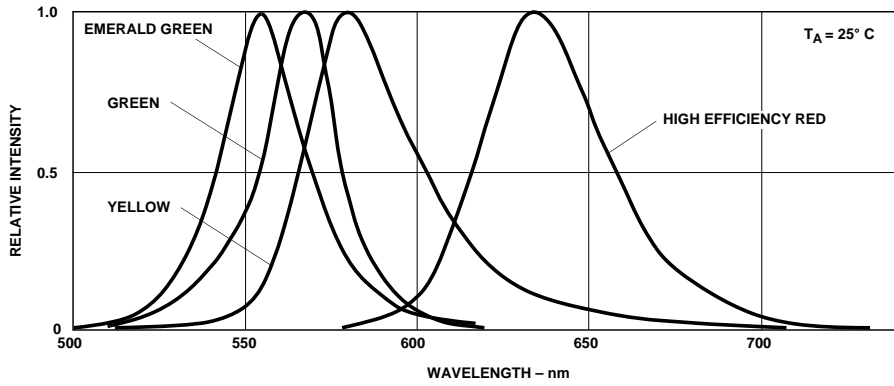

Figure 1. Relative Intensity vs. Wavelength.

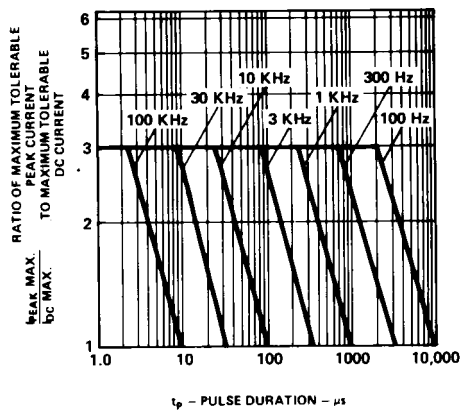

Figure 2. Maximum Tolerable Peak Current vs. Pulse Duration. ($I_{DC \text{ MAX}}$ as per MAX Ratings).

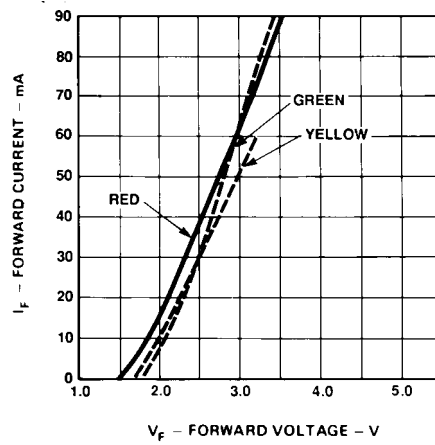

Figure 3. Forward Current vs. Forward Voltage.

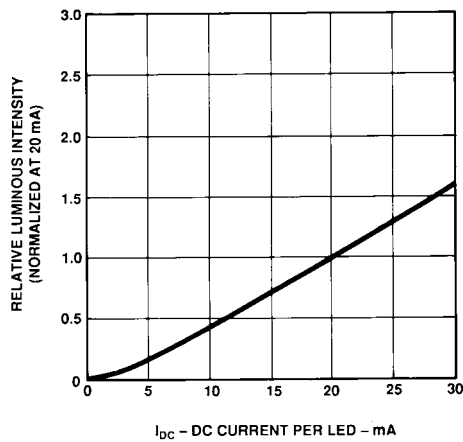

Figure 4. Relative Luminous Intensity vs. Forward Current.

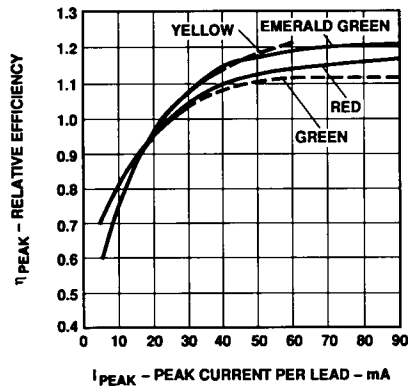

Figure 5. Relative Efficiency (Luminous Intensity per Unit Current) vs. Peak Current.

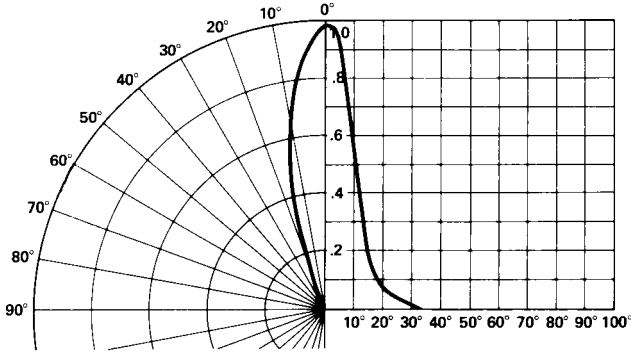

Figure 6. Relative Luminous Intensity vs. Angular Displacement. T-1^{3/4} Lamp.

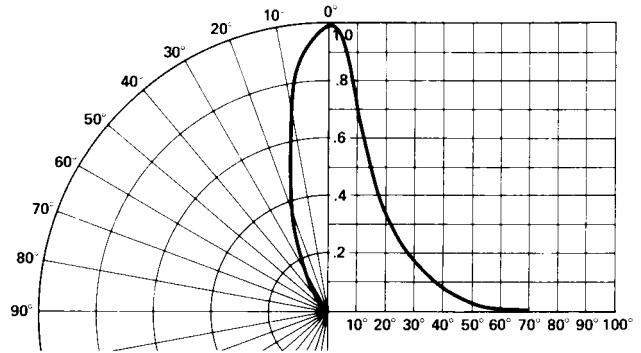

Figure 7. Relative Luminous Intensity vs. Angular Displacement. T-1^{3/4} Low Profile Lamp.

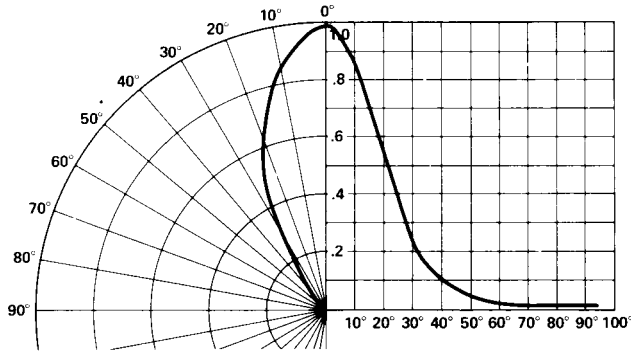

Figure 8. Relative Luminous Intensity vs. Angular Displacement. T-1 Lamp.

Intensity Bin Limits

Intensity Bin Limits

Color	Bin	Intensity Range (mcd)	
		Min.	Max.
Red	G	9.7	15.5
	H	15.5	24.8
	I	24.8	39.6
	J	39.6	63.4
	K	63.4	101.5
	L	101.5	162.4
	M	162.4	234.6
	N	234.6	340.0
	O	340.0	540.0
	P	540.0	850.0
	Q	850.0	1200.0
	R	1200.0	1700.0
	S	1700.0	2400.0
	T	2400.0	3400.0
	U	3400.0	4900.0
	V	4900.0	7100.0
	W	7100.0	10200.0
X	10200.0	14800.0	
Y	14800.0	21400.0	
Z	21400.0	30900.0	

Maximum tolerance for each bin limit is ± 18%.

Intensity Bin Limits (continued)

Color	Bin	Intensity Range (mcd)		
		Min.	Max.	
Yellow	H	26.5	42.3	
	I	42.3	67.7	
	J	67.7	108.2	
	K	108.2	173.2	
	L	173.2	250.0	
	M	250.0	360.0	
	N	360.0	510.0	
	O	510.0	800.0	
	P	800.0	1250.0	
	Q	1250.0	1800.0	
	R	1800.0	2900.0	
	S	2900.0	4700.0	
	T	4700.0	7200.0	
	U	7200.0	11700.0	
	V	11700.0	18000.0	
	W	18000.0	27000.0	
	Green/ Emerald Green	A	1.1	1.8
		B	1.8	2.9
C		2.9	4.7	
D		4.7	7.6	
E		7.6	12.0	
F		12.0	19.1	
G		19.1	30.7	
H		30.7	49.1	
I		49.1	78.5	
J		78.5	125.7	
K		125.7	201.1	
L		201.1	289.0	
M		289.0	417.0	
N		417.0	680.0	
O		680.0	1100.0	
P		1100.0	1800.0	
Q		1800.0	2700.0	
R		2700.0	4300.0	
S	4300.0	6800.0		
T	6800.0	10800.0		
U	10800.0	16000.0		
V	16000.0	25000.0		
W	25000.0	40000.0		

Maximum tolerance for each bin limit is $\pm 18\%$.

Color Categories

Color	Cat #	Lambda (nm)	
		Min.	Max.
Emerald Green	9	552.5	555.5
	8	555.5	558.5
	7	558.5	561.5
	6	561.5	564.5
Green	6	561.5	564.5
	5	564.5	567.5
	4	567.5	570.5
	3	570.5	573.5
	2	573.5	576.5
Yellow	1	582.0	584.5
	3	584.5	587.0
	2	587.0	589.5
	4	589.5	592.0
	5	592.0	593.0
Orange	1	597.0	599.5
	2	599.5	602.0
	3	602.0	604.5
	4	604.5	607.5
	5	607.5	610.5
	6	610.5	613.5
	7	613.5	616.5
	8	616.5	619.5

Maximum tolerance for each bin limit is $\pm 0.5\text{nm}$.

Mechanical Option Matrix

Mechanical Option Code	Definition
00	Bulk Packaging, minimum increment 500 pcs/bag
01	Tape & Reel, crimped leads, min. increment 1300 pcs/bag for T-1 ^{3/4} , 1800 pcs/bag for T-1
02	Tape & Reel, straight leads, min. increment 1300 pcs/bag for T-1 ^{3/4} , 1800 pcs/bag for T-1
A1	T-1, Right Angle Housing, uneven leads, minimum increment 500 pcs/bag
A2	T-1, Right Angle Housing, even leads, minimum increment 500 psc/bag
B1	T-1 ^{3/4} , Right Angle Housing, uneven leads, minimum increment 500 pcs/bag
B2	T-1 ^{3/4} , Right Angle Housing, even leads, minimum increment 500 psc/bag
BJ	T-1, Tape & Reel, straight leads, minimum increment 2000 pcs/bag
EG	Ammo Pack, straight leads in 5 K increment
FH	Devices that require inventory control and 2 I _v bin select
VR	Ammo Pack, crimped leads, min. increment 2 k for T-1 ^{3/4} and T-1

Note:

All categories are established for classification of products. Products may not be available in all categories. Please contact your local Agilent representative for further clarification/information.

www.agilent.com/semiconductors

For product information and a complete list of distributors, please go to our web site.

For technical assistance call:

Americas/Canada: +1 (800) 235-0312 or
(408) 654-8675

Europe: +49 (0) 6441 92460

China: 10800 650 0017

Hong Kong: (+65) 6756 2394

India, Australia, New Zealand: (+65) 6755 1939

Japan: (+81 3) 3335-8152(Domestic/International),
or 0120-61-1280(Domestic Only)

Korea: (+65) 6755 1989

Singapore, Malaysia, Vietnam, Thailand,
Philippines, Indonesia: (+65) 6755 2044

Taiwan: (+65) 6755 1843

Data subject to change.

Copyright © 2003 Agilent Technologies, Inc.

Obsoletes 5988-8520EN

April 8, 2003

5988-9363EN



LittleDiode supplies new, hard to find or obsolete electronic components and semiconductors all over the world.

With over two million different components listed you are sure to find the part you need.

Feel free to visit us today at our online store:

LittleDiode.com

Looking forward to providing you with the best possible service.