

# T-1<sup>3/4</sup> (5 mm), T-1 (3 mm), 5 Volt, 12 Volt, Integrated Resistor LED Lamps

## Technical Data

HLMP-1600, HLMP-1601  
HLMP-1620, HLMP-1621  
HLMP-1640, HLMP-1641  
HLMP-3600, HLMP-3601  
HLMP-3650, HLMP-3651  
HLMP-3680, HLMP-3681

### Features

- **Integral Current Limiting Resistor**
- **TTL Compatible**  
Requires no External Current Limiter with 5 Volt/12 Volt Supply
- **Cost Effective**  
Saves Space and Resistor Cost
- **Wide Viewing Angle**
- **Available in All Colors**  
Red, High Efficiency Red, Yellow, and High Performance Green in T-1 and T-1<sup>3/4</sup> Packages

### Description

The 5 volt and 12 volt series lamps contain an integral current limiting resistor in series with the LED. This allows the lamp to be driven from a 5 volt/12 volt source without an external current limiter. The red LEDs are made from GaAsP on a GaAs substrate. The High Efficiency Red and Yellow devices use GaAsP on a GaP substrate.

The green devices use GaP on a GaP substrate. The diffused lamps provide a wide off-axis viewing angle.

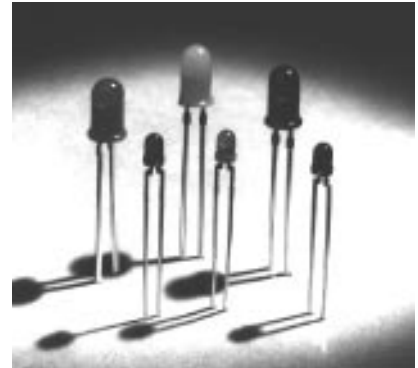

The T-1<sup>3/4</sup> lamps are provided with sturdy leads suitable for wire wrap applications. The T-1<sup>3/4</sup> lamps may be front panel mounted by using the HLMP-0103 clip and ring.

### Package Dimensions

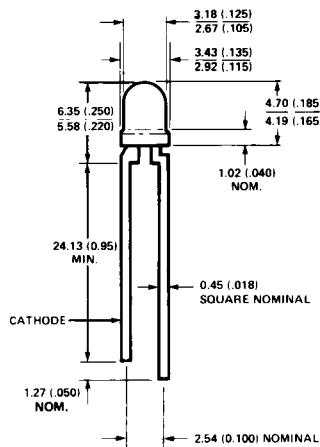

Figure A. T-1 Package.

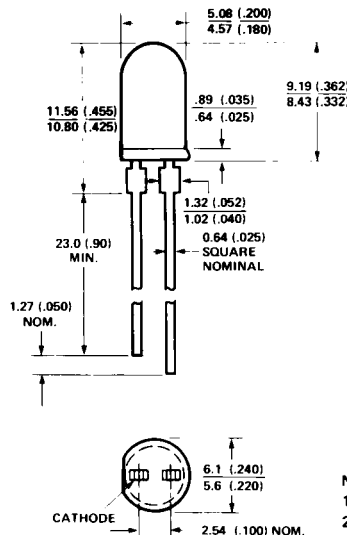

Figure B. T-1<sup>3/4</sup> Package.

NOTES:  
1. ALL DIMENSIONS ARE IN MILLIMETRES (INCHES).  
2. AN EPOXY MENISCUS MAY EXTEND ABOUT 1mm (.040") DOWN THE LEADS.

## Selection Guide

Color	Part Number HLMP-	Package	Operating Voltage	I <sub>v</sub> mcd		2θ <sup>1/2</sup> [1]	Package Outline
				Min.	Typ.		
High Efficiency Red	1600	T-1 Tinted Diffused	5	2.1	8.0	60°	A
	1601		12				
	3600	T-1 <sup>3/4</sup> Tinted Diffused	5			60°	B
	3601		12				
Yellow	1620	T-1 Tinted Diffused	5	2.2	8.0	60°	A
	1621		12				
	3650	T-1 <sup>3/4</sup> Tinted Diffused	5			60°	B
	3651		12				
High Performance Green	1640	T-1 Tinted Diffused	5	1.6	8.0	60°	A
	1641		12				
	3680	T-1 <sup>3/4</sup> Tinted Diffused	5			60°	B
	3681		12				

**Note:**

1. θ<sub>1/2</sub> is the off-axis angle at which the luminous intensity is 1/2 the axial luminous intensity.

## Absolute Maximum Ratings at T<sub>A</sub> = 25°C

	Red/HER/ Yellow 5 Volt Lamps	Red/HER/ Yellow 12 Volt Lamps	Green 5 Volt Lamps	Green 12 Volt Lamps
DC Forward Voltage (T <sub>A</sub> = 25°C)	7.5 Volts <sup>[2]</sup>	15 Volts <sup>[3]</sup>	7.5 Volts <sup>[2]</sup>	15 Volts <sup>[3]</sup>
Reverse Voltage (I <sub>R</sub> = 100 μA)	5 Volts	5 Volts	5 Volts	5 Volts
Operating Temperature Range	-40°C to 85°C	-40°C to 85°C	-20°C to 85°C	-20°C to 85°C
Storage Temperature Range	-55°C to 100°C	-55°C to 100°C	-55°C to 100°C	-55°C to 100°C
Lead Soldering Temperature	260°C for 5 seconds			

**Notes:**

2. Derate from T<sub>A</sub> = 50°C at 0.071 V/°C, see Figure 3.

3. Derate from T<sub>A</sub> = 50°C at 0.086 V/°C, see Figure 4.

## Electrical/Optical Characteristics at $T_A = 25^\circ\text{C}$

Symbol	Description	High Efficiency Red			Yellow			Green			Unit	Test Condition
		Min.	Typ.	Max.	Min.	Typ.	Max.	Min.	Typ.	Max.		
$\lambda_p$	Peak Wavelength		635			583			565		nm	
$\lambda_d$	Dominant Wavelength		626			585			569		nm	Note 4
$\Delta\lambda^{1/2}$	Spectral Line Halfwidth		40			36			28		nm	
$R\theta_{J-PIN}$	Thermal Resistance		290			290			290		$^\circ\text{C/W}$	Junction to Cathode Lead (Note 6)
$R\theta_{J-PIN}$	Thermal Resistance		210			210			210		$^\circ\text{C/W}$	Junction to Cathode Lead (Note 7)
$I_F$	Forward Current 12 V Devices		13	20		13	20		13	20	mA	$V_F = 12\text{ V}$
$I_F$	Forward Current 5 V Devices		10	15		10	15		10	15	mA	$V_F = 5\text{ V}$
$\eta_V$	Luminous Efficacy		145			500			595		lumen/Watt	Note 2
$V_R$	Reverse Breakdown Voltage	5.0			5.0			5.0			V	$I_R = 100\ \mu\text{A}$

### Notes:

- The dominant wavelength,  $\lambda_d$ , is derived from the CIE chromaticity diagram and represents the single wavelength which defines the color of the device.
- Radiant intensity,  $I_e$ , in watts/steradian, may be found from the equation  $I_e = I_v/\eta_V$ , where  $I_v$  is the luminous intensity in candelas and  $\eta_V$  is the luminous efficacy in lumens/Watt.
- For Figure A package type.
- For Figure B package type.

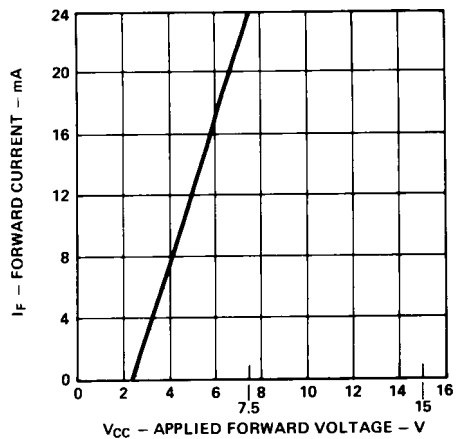

Figure 1. Forward Current vs. Applied Forward Voltage. 5 Volt Devices.

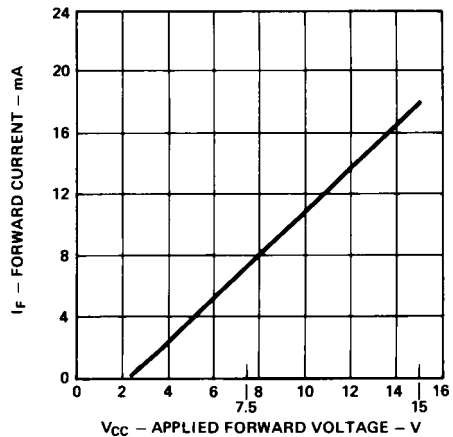

Figure 2. Forward Current vs. Applied Forward Voltage. 12 Volt Devices.

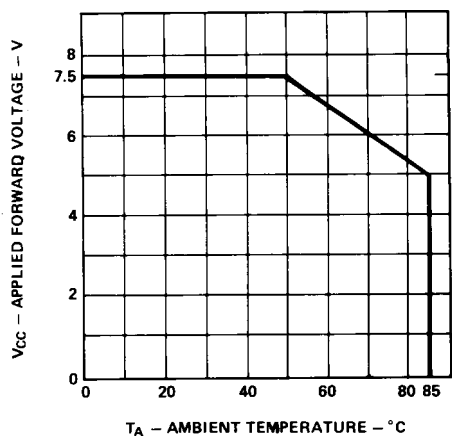

Figure 3. Maximum Allowed Applied Forward Voltage vs. Ambient Temperature  $R\theta_{JA} = 175^{\circ}\text{C/W}$ . 5 Volt Devices.

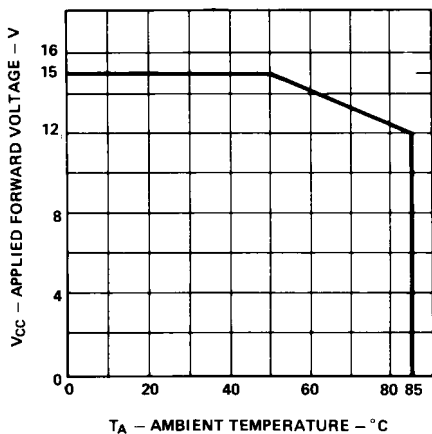

Figure 4. Maximum Allowed Applied Forward Voltage vs. Ambient Temperature  $R\theta_{JA} = 175^{\circ}\text{C/W}$ . 12 Volt Devices.

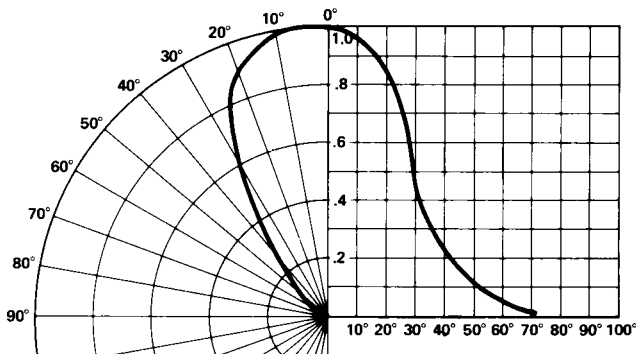

Figure 4. Relative Luminous Intensity vs. Angular Displacement for T-1 Package.

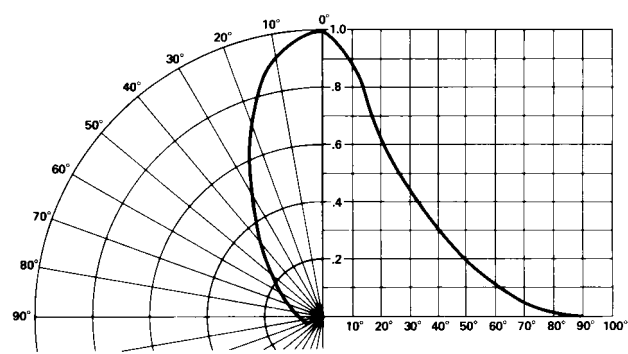

Figure 5. Relative Luminous Intensity vs. Angular Displacement for T-1<sup>3/4</sup> Package.

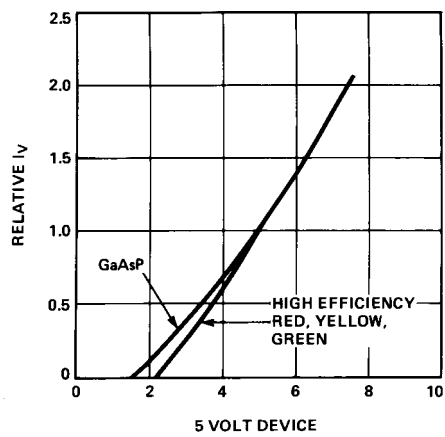

Figure 6. Relative Luminous Intensity vs. Applied Forward Voltage. 5 Volt Devices.

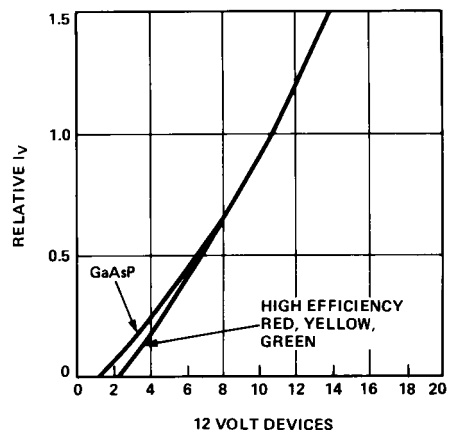

Figure 7. Relative Luminous Intensity vs. Applied Forward Voltage. 12 Volt Devices.



LittleDiode supplies new, hard to find or obsolete electronic components and semiconductors all over the world.

With over two million different components listed you are sure to find the part you need.

Feel free to visit us today at our online store:

**[LittleDiode.com](http://LittleDiode.com)**

Looking forward to providing you with the best possible service.