

HD14553B

Three-Digit BCD Counter

The HD14553B three-digit BCD counter consists of three negative-edge triggered BCD counters that are cascaded synchronously. A quad latch at the output of each counter permits storage of any given count. The information is then time division multiplexed, providing on BCD number or digit at a time. Digit select outputs provide display control. All outputs are TTL compatible. An on-chip oscillator provides the low-frequency scanning clock which drives the multiplexer output selector. This device is used in instrumentation counters, clock displays, digital panel meters, and as a building block for general logic applications.

FEATURES

- TTL Outputs
- On-Chip Oscillator
- Cascadable
- Clock Disable Input
- Pulse Shaping Permits Very Slow Rise Times on Input Clock
- Output Latches
- Master Reset

BLOCK DIAGRAM

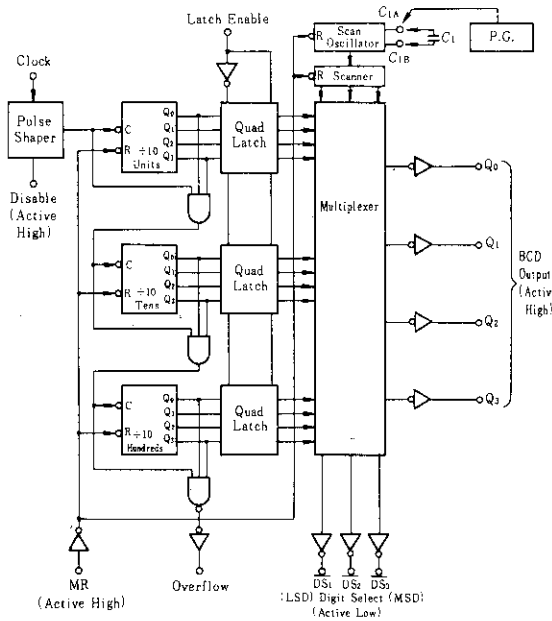

PIN ARRANGEMENT

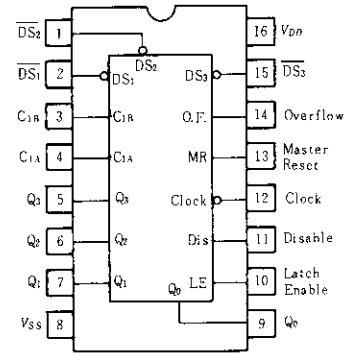

(Top View)

TRUTH TABLE

Inputs				Outputs
MR	Clock	Disable	LE	
0		0	0	No Change
0		0	0	Advance
0	x	1	x	No Change
0	1		0	Advance
0	1		0	No Change
0	0	x	x	No Change
0	x	x		Latched
0	x	x	1	Latched
1	x	x	0	$Q_0 \sim Q_3 = 0$

x = Don't Care

MAXIMUM RATINGS (Voltages refeeced to V_{SS})

Characteristic	Symbol	Value	Unit
DC Supply Voltage	V_{DD}	-0.5 ~ +18	V
Input/Output Voltage	V_{in}, V_{out}	-0.5 ~ $V_{DD} + 0.5$	V
DC Current Drain per Input Pin	I_{in}	± 10	mA
DC Current per Pin, All Outputs	I_{out}	20	mA
Operating Temperature Range	T_A	-40 ~ +85	°C
Storage Temperature Range	T_{stg}	-65 ~ +150	°C
Power Dissipation	P_D	300	mW

■ ELECTRICAL CHARACTERISTICS

Characteristic	Symbol	Test Conditions	-40°C		25°C			85°C		Unit		
			min	max	min	typ	max	min	max			
Output Voltage	V_{OL}	5.0	$V_{in} = V_{DD}$ or 0	—	0.05	—	0	0.05	—	0.05	V	
		10		—	0.05	—	0	0.05	—	0.05		
		15		—	0.05	—	0	0.05	—	0.05		
	V_{OH}	5.0	$V_{in} = 0$ or V_{DD}	4.95	—	4.95	5.0	—	4.95	—	V	
		10		9.95	—	9.95	10	—	9.95	—		
		15		14.95	—	14.95	15	—	14.95	—		
Input Voltage	V_{iL}	5.0	$V_{out} = 4.5$ or $0.5V$	—	1.5	—	2.25	1.5	—	1.5	V	
		10	$V_{out} = 9.0$ or $1.0V$	—	3.0	—	4.50	3.0	—	3.0		
		15	$V_{out} = 13.5$ or $1.5V$	—	4.0	—	6.75	4.0	—	4.0		
	V_{iH}	5.0	$V_{out} = 0.5$ or $4.5V$	3.5	—	3.5	2.75	—	3.5	—	V	
		10	$V_{out} = 1.0$ or $9.0V$	7.0	—	7.0	5.50	—	7.0	—		
		15	$V_{out} = 1.5$ or $13.5V$	11.0	—	11.0	8.25	—	11.0	—		
Output Drive Current	I_{OH}	5.0	$V_{OH} = 4.6V$	-0.2	—	-0.16	-0.36	—	-0.12	—	mA	
		10	$V_{OH} = 9.5V$	-0.5	—	-0.4	-0.9	—	-0.3	—		
		15	$V_{OH} = 13.5V$	-1.4	—	-1.2	-3.5	—	-1.0	—		
	Pin 3	I_{OL}	5.0	$V_{OL} = 0.4V$	0.52	—	0.44	0.88	—	0.36	—	mA
			10	$V_{OL} = 0.5V$	1.3	—	1.1	2.25	—	0.9	—	
			15	$V_{OL} = 1.5V$	3.6	—	3.0	8.8	—	2.4	—	
		Other Outputs	5.0	$V_{OL} = 0.4V$	2.4	—	2.0	4.0	—	1.6	—	
			10	$V_{OL} = 0.5V$	3.8	—	3.0	8.0	—	2.5	—	
			15	$V_{OL} = 1.5V$	10	—	8.4	20	—	7.0	—	
	Input Current	I_{in}	15		—	± 0.3	—	± 0.00001	± 0.3	—	± 1.0	μA
	Input Capacitance	C_{in}		$V_{in} = 0$	—	—	—	5.0	7.5	—	—	pF
	Quiescent Current	I_{DD}	5.0	Zero Signal, per Package	—	50	—	0.010	50	—	375	μA
10			—		100	—	0.020	100	—	750		
15			—		200	—	0.030	200	—	1500		
Total Supply Current*	I_T	5.0	Dynamic + I_{DD} ,	—	—	—	0.35	—	—	—	μA	
		10	per Gate	—	—	—	0.85	—	—	—		
		15	$C_L = 50pF, f = 1 kHz$	—	—	—	1.50	—	—	—		

* To calculate total supply current at frequency other than 1kHz.

@ $V_{DD} = 5.0V$ $I_T = (0.35 \mu A/kHz)f + I_{DD}$, @ $V_{DD} = 10V$ $I_T = (0.85 \mu A/kHz)f + I_{DD}$, @ $V_{DD} = 15V$ $I_T = (1.50 \mu A/kHz)f + I_{DD}$

■ SWITCHING TIME TEST CIRCUIT

1.

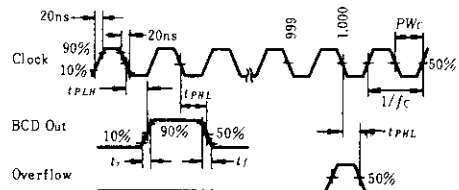
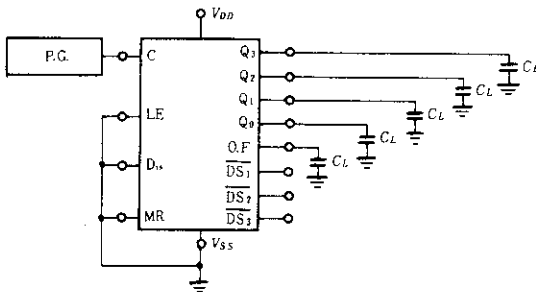

2.

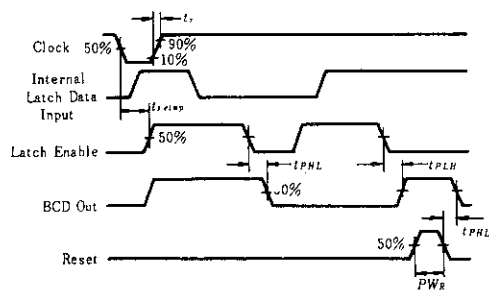
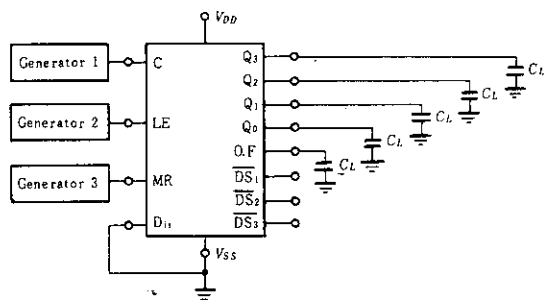

■ SWITCHING CHARACTERISTICS ($C_L=50\text{pF}$, $T_a=25^\circ\text{C}$)

Characteristic		Symbol	Test Circuit	V_{DD} (V)	min	typ	max	Unit
Output Rise Time		t_r	1	5.0	—	180	400	ns
				10	—	90	200	
				15	—	65	160	
Output Fall Time		t_f	1	5.0	—	120	250	ns
				10	—	60	125	
				15	—	40	100	
Propagation Delay Time	Clock to BCD Out	t_{PLH} , t_{PHL}	1	5.0	—	900	2000	ns
				10	—	500	1000	
				15	—	300	750	
	Clock to Overflow	t_{PHL}	1	5.0	—	600	1300	ns
				10	—	400	800	
				15	—	200	600	
	Reset to BCD Out	t_{PHL}	2	5.0	—	900	2000	ns
				10	—	500	1000	
				15	—	300	750	
Setup Time		t_{setup}	2	5.0	900	300	—	ns
				10	500	200	—	
				15	375	100	—	
Clock Pulse Width		PW_C	1	5.0	550	275	—	ns
				10	200	100	—	
				15	150	75	—	
Reset Pulse Width		PW_R	2	5.0	1200	600	—	ns
				10	600	300	—	
				15	450	225	—	
Clock Frequency		f_c	1	5.0	—	1.5	0.7	MHz
				10	—	5.0	2.0	
				15	—	7.0	2.5	
Input Clock Rise Time		t_r	2	5.0	No Limit			
				10				
				15				
Scon Oscillator Frequency		f_{osc}		5.0	—	$0.4/C_1^*$	—	Hz
				10	—	$1.2/C_1^*$	—	
				15	—	$1.6/C_1^*$	—	

* $C_1 = \mu\text{F}$

● TIMING DIAGRAM

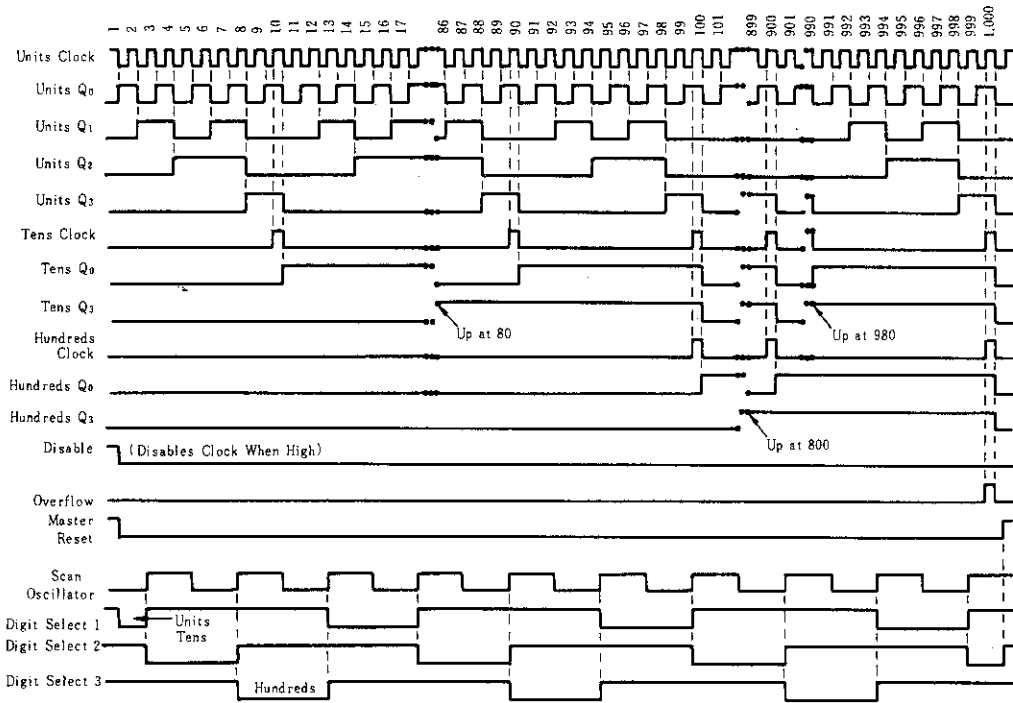

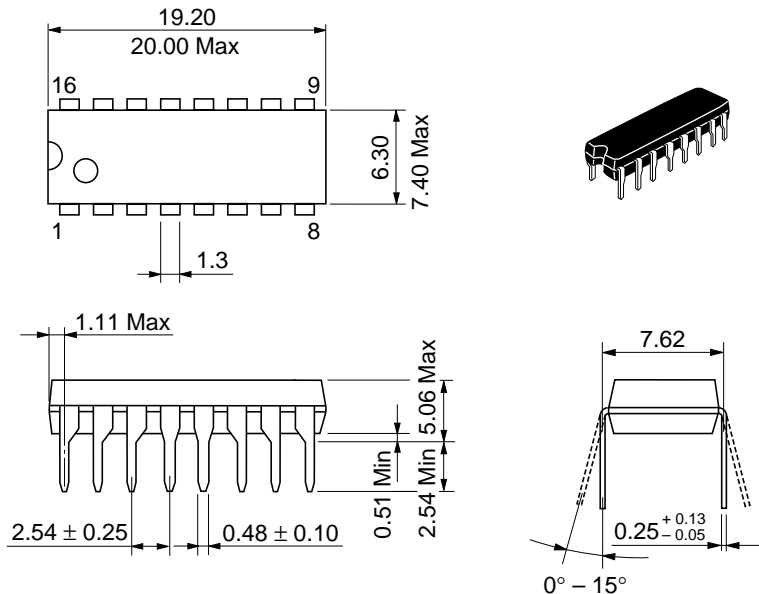

Hitachi Code	DP-16
JEDEC	Conforms
EIAJ	Conforms
Weight (reference value)	1.07 g

Cautions

1. Hitachi neither warrants nor grants licenses of any rights of Hitachi's or any third party's patent, copyright, trademark, or other intellectual property rights for information contained in this document. Hitachi bears no responsibility for problems that may arise with third party's rights, including intellectual property rights, in connection with use of the information contained in this document.
2. Products and product specifications may be subject to change without notice. Confirm that you have received the latest product standards or specifications before final design, purchase or use.
3. Hitachi makes every attempt to ensure that its products are of high quality and reliability. However, contact Hitachi's sales office before using the product in an application that demands especially high quality and reliability or where its failure or malfunction may directly threaten human life or cause risk of bodily injury, such as aerospace, aeronautics, nuclear power, combustion control, transportation, traffic, safety equipment or medical equipment for life support.
4. Design your application so that the product is used within the ranges guaranteed by Hitachi particularly for maximum rating, operating supply voltage range, heat radiation characteristics, installation conditions and other characteristics. Hitachi bears no responsibility for failure or damage when used beyond the guaranteed ranges. Even within the guaranteed ranges, consider normally foreseeable failure rates or failure modes in semiconductor devices and employ systemic measures such as fail-safes, so that the equipment incorporating Hitachi product does not cause bodily injury, fire or other consequential damage due to operation of the Hitachi product.
5. This product is not designed to be radiation resistant.
6. No one is permitted to reproduce or duplicate, in any form, the whole or part of this document without written approval from Hitachi.
7. Contact Hitachi's sales office for any questions regarding this document or Hitachi semiconductor products.

HITACHI

Hitachi, Ltd.

Semiconductor & Integrated Circuits.
Nippon Bldg., 2-6-2, Ohte-machi, Chiyoda-ku, Tokyo 100-0004, Japan
Tel: Tokyo (03) 3270-2111 Fax: (03) 3270-5109

URL North America : <http://semiconductor.hitachi.com/>
 Europe : <http://www.hitachi-eu.com/hel/ecg>
 Asia (Singapore) : <http://www.has.hitachi.com.sg/grp3/sicd/index.htm>
 Asia (Taiwan) : http://www.hitachi.com.tw/E/Product/SICD_Frame.htm
 Asia (HongKong) : <http://www.hitachi.com.hk/eng/bo/grp3/index.htm>
 Japan : <http://www.hitachi.co.jp/Sicd/indx.htm>

For further information write to:

Hitachi Semiconductor
(America) Inc.
179 East Tasman Drive,
San Jose, CA 95134
Tel: <1> (408) 433-1990
Fax: <1> (408) 433-0223

Hitachi Europe GmbH
Electronic components Group
Dornacher Straße 3
D-85622 Feldkirchen, Munich
Germany
Tel: <49> (89) 9 9180-0
Fax: <49> (89) 9 29 30 00

Hitachi Europe Ltd.
Electronic Components Group.
Whitebrook Park
Lower Cookham Road
Maidenhead
Berkshire SL6 8YA, United Kingdom
Tel: <44> (1628) 585000
Fax: <44> (1628) 778322

Hitachi Asia Pte. Ltd.
16 Collyer Quay #20-00
Hitachi Tower
Singapore 049318
Tel: 535-2100
Fax: 535-1533

Hitachi Asia Ltd.
Taipei Branch Office
3F, Hung Kuo Building, No.167,
Tun-Hwa North Road, Taipei (105)
Tel: <886> (2) 2718-3666
Fax: <886> (2) 2718-8180

Hitachi Asia (Hong Kong) Ltd.
Group III (Electronic Components)
7/F., North Tower, World Finance Centre,
Harbour City, Canton Road, Tsim Sha Tsui,
Kowloon, Hong Kong
Tel: <852> (2) 735 9218
Fax: <852> (2) 730 0281
Telex: 40815 HITEC HX

Copyright ' Hitachi, Ltd., 1999. All rights reserved. Printed in Japan.

HITACHI



LittleDiode supplies new, hard to find or obsolete electronic components and semiconductors all over the world.

With over two million different components listed you are sure to find the part you need.

Feel free to visit us today at our online store:

LittleDiode.com

Looking forward to providing you with the best possible service.