

HD14536B

Programmable Timer

The HD14536B programmable timer is a flexible 24-stage ripple binary counter with 16 stages selectable by a binary code. Provisions for an on-chip RC oscillator, or an external clock are provided. An on-chip monostable circuit incorporating a pulse-type output has also been included. By selecting the appropriate output in conjunction with the correct input clock frequency, a variety of timing can be achieved.

FEATURES

- 24 Flip-Flop Stages ... Will Count from 2^0 to 2^{24}
- Last 16 Stages Selectable by Four-Bit Select Code
- Input Allows Bypassing of First Eight Stages
- Set and Reset Inputs
- Clock Inhibit Input
- On-Chip RC Oscillator Provisions
- On-Chip Monostable Output Provisions
- Clock Conditioning Circuit Permits Operation with Very Long Rise and Fall Times
- Clock Input $f_{max} = 3\text{MHz typ. @}10\text{V}$
- Counter Advances On Negative Going Edge of Clock
- Test Mode Allows Fast Test Sequence
- Supply Voltage Range = 3 to 18V
- Capable of Driving One Low-power Schottky TTL Load Over the Rated Temperature Range

PIN ARRANGEMENT

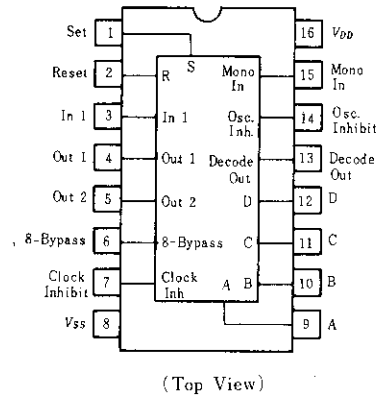

TRUTH TABLE

D	C	B	A	Decode Out	8-Bypass
0	0	0	0	9	1
0	0	0	1	10	2
0	0	1	0	11	3
0	0	1	1	12	4
0	1	0	0	13	5
0	1	0	1	14	6
0	1	1	0	15	7
0	1	1	1	16	8
1	0	0	0	17	9
1	0	0	1	18	10
1	0	1	0	19	11
1	0	1	1	20	12
1	1	0	0	21	13
1	1	0	1	22	14
1	1	1	0	23	15
1	1	1	1	24	16

BLOCK DIAGRAM

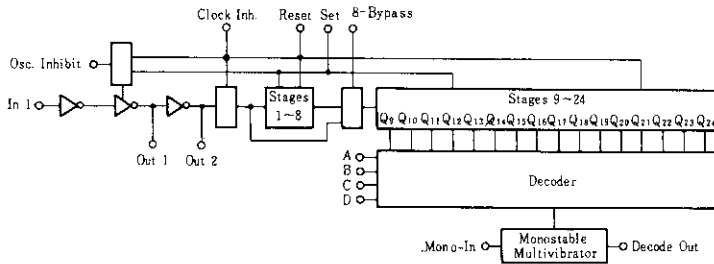

In 1	Set	Reset	Clock Inhibit	Osc. Inhibit	Out 1	Out 2	Decode Out
	0	0	0	0			No Change
	0	0	0	0			Advance to next stage
x	1	0	0	0	0	1	1
x	0	1	0	0	0	1	0
x	0	0	1	0			No Change
0	0	0	0	x	0	1	No Change
1	0	0	0				Advance to next stage

x Don't Care

LOGIC DIAGRAM

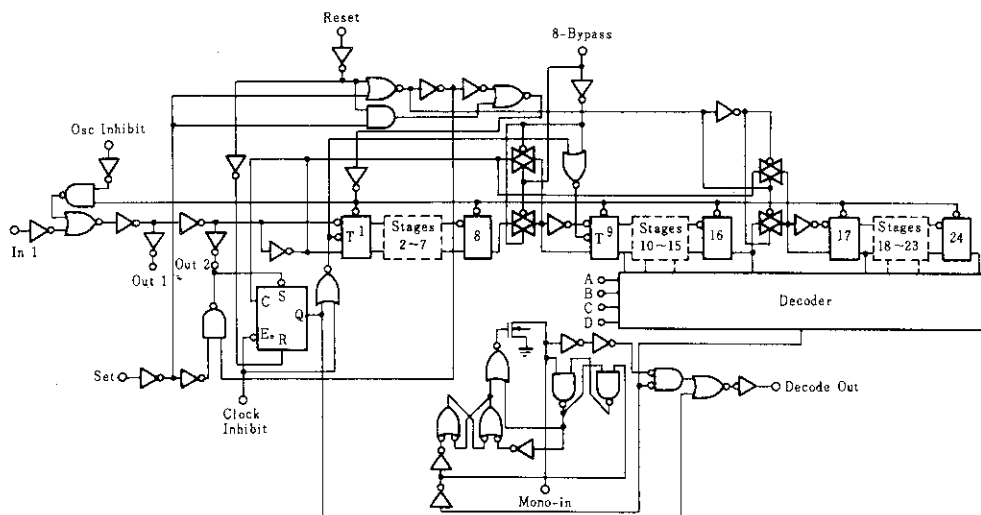

ELECTRICAL CHARACTERISTICS

Characteristic	Symbol	V _{DD} (V)	Test Conditions	-40°C		25°C			85°C		Unit
				min	max	min	typ	max	min	max	
Output Voltage	V _{OL}	5.0	V _{in} =V _{DD} or 0	—	0.05	—	0	0.05	—	0.05	V
		10		—	0.05	—	0	0.05	—	0.05	
		15		—	0.05	—	0	0.05	—	0.05	
	V _{OH}	5.0	V _{in} =0 or V _{DD}	4.95	—	4.95	5.0	—	4.95	—	V
		10		9.95	—	9.95	10	—	9.95	—	
		15		14.95	—	14.95	15	—	14.95	—	
Input Voltage	V _{IL}	5.0	V _{out} =4.5 or 0.5V	—	1.5	—	2.25	1.5	—	1.5	V
		10	V _{out} =9.0 or 1.0V	—	3.0	—	4.50	3.0	—	3.0	
		15	V _{out} =13.5 or 1.5V	—	4.0	—	6.75	4.0	—	4.0	
	V _{IH}	5.0	V _{out} =0.5 or 4.5V	3.5	—	3.5	2.75	—	3.5	—	V
		10	V _{out} =1.0 or 9.0V	7.0	—	7.0	5.50	—	7.0	—	
		15	V _{out} =1.5 or 13.5V	11.0	—	11.0	8.25	—	11.0	—	
Output Drive Current	I _{OH}	5.0	V _{OH} =2.5V	-1.0	—	-0.8	-1.7	—	-0.6	—	mA
		5.0	V _{OH} =4.6V	-0.2	—	-0.16	-0.36	—	-0.12	—	
		10	V _{OH} =9.5V	-0.5	—	-0.4	-0.9	—	-0.3	—	
	I _{OL}	5.0	V _{OL} =0.4V	0.52	—	0.44	0.88	—	0.36	—	mA
		10	V _{OL} =0.5V	1.3	—	1.1	2.25	—	0.9	—	
		15	V _{OL} =1.5V	3.6	—	3.0	8.8	—	2.4	—	
Input Current	I _{in}	15		—	±0.3	—	±0.0001	±0.3	—	±1.0	μA
Input Capacitance	C _{in}	—	V _{in} =0	—	—	—	5.0	7.5	—	—	pF
Quiescent Current	I _{DD}	5.0	Zero Signal, per Package	—	50	—	0.010	50	—	375	μA
		10		—	100	—	0.020	100	—	750	
		15		—	200	—	0.030	200	—	1500	
Total Supply Current*	I _T	5.0	Dynamic + I _{DD} , per Gate	—	—	—	1.15	—	—	—	μA
		10		—	—	—	2.3	—	—	—	
		15		—	—	—	3.55	—	—	—	

* To calculate total supply current at frequency other than 1kHz.

@V_{DD}=5.0V I_T=(1.15μA/kHz)f+I_{DD}, @V_{DD}=10V I_T=(2.3μA/kHz)f+I_{DD}, @V_{DD}=15V I_T=(3.55μA/kHz)f+I_{DD}

●POWER DISSIPATION TEST
CIRCUIT AND WAVEFORM

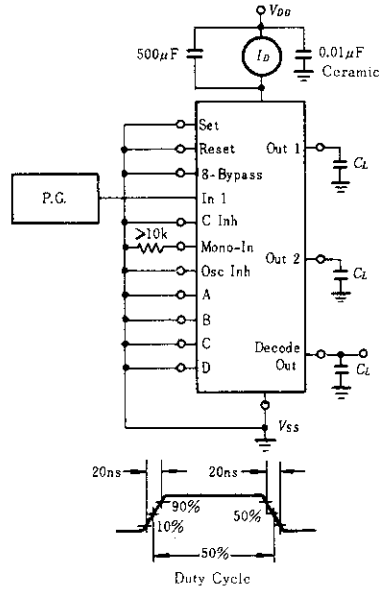

■ SWITCHING CHARACTERISTICS ($C_L=50\text{pF}$, $T_a=25^\circ\text{C}$)

Characteristic		Symbol	$V_{DD}(V)$	min	typ	max	Unit	
Output Rise Time		t_r	5.0	—	180	400	ns	
			10	—	90	200		
			15	—	65	160		
Output Fall Time		t_f	5.0	—	120	250	ns	
			10	—	60	125		
			15	—	40	100		
Propagation Delay Time	Clock to Q_1 (Pin 6 High)	t_{PLH}	5.0	—	1800	5400	ns	
			10	—	650	2000		
			15	—	450	1500		
	Clock to Q_1 (Pin 6 Low)	t_{PHL}	5.0	—	3.8	12	μs	
			10	—	1.5	4.5		
			15	—	1.1	3.5		
	Clock to Q_{1c}		5.0	—	7.0	21	μs	
			10	—	3.0	9.0		
			15	—	2.2	7.0		
	Reset to Q_n		t_{PHL}	5.0	—	1500	4500	ns
				10	—	600	1800	
				15	—	450	1400	
Clock Pulse Width		PW_C	5.0	900	300	—	ns	
			10	300	100	—		
			15	255	85	—		
Clock Frequency		PRF	5.0	—	1.2	0.4	MHz	
			10	—	3.0	1.5		
			15	—	5.0	2.0		
Clock Pulse Rise and Fall Time		t_r, t_f	5.0	No Limit				
			10					
			15					
Reset Pulse Width		PW_R	5.0	1500	500	—	ns	
			10	600	200	—		
			15	450	150	—		

■ SWITCHING TIME TEST CIRCUIT

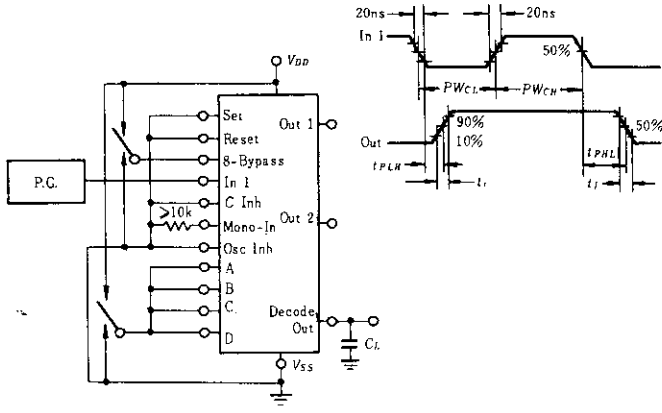

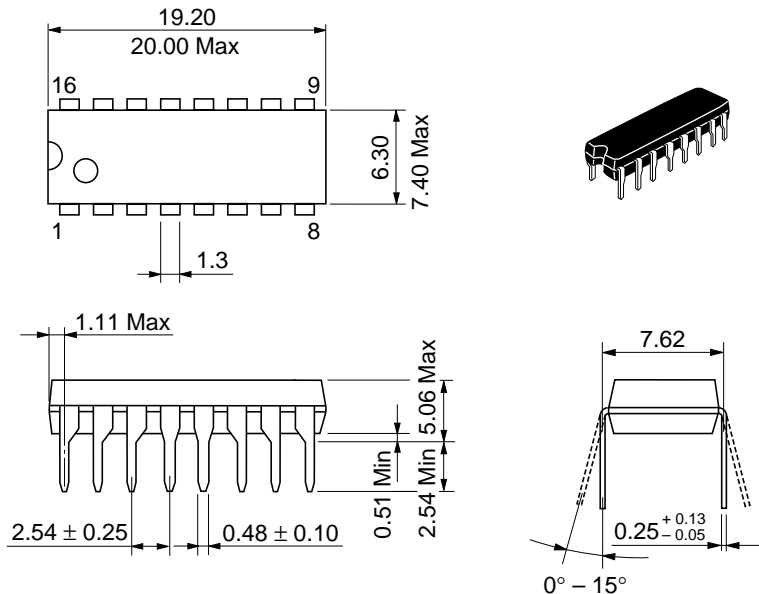

Hitachi Code	DP-16
JEDEC	Conforms
EIAJ	Conforms
Weight (reference value)	1.07 g

Cautions

1. Hitachi neither warrants nor grants licenses of any rights of Hitachi's or any third party's patent, copyright, trademark, or other intellectual property rights for information contained in this document. Hitachi bears no responsibility for problems that may arise with third party's rights, including intellectual property rights, in connection with use of the information contained in this document.
2. Products and product specifications may be subject to change without notice. Confirm that you have received the latest product standards or specifications before final design, purchase or use.
3. Hitachi makes every attempt to ensure that its products are of high quality and reliability. However, contact Hitachi's sales office before using the product in an application that demands especially high quality and reliability or where its failure or malfunction may directly threaten human life or cause risk of bodily injury, such as aerospace, aeronautics, nuclear power, combustion control, transportation, traffic, safety equipment or medical equipment for life support.
4. Design your application so that the product is used within the ranges guaranteed by Hitachi particularly for maximum rating, operating supply voltage range, heat radiation characteristics, installation conditions and other characteristics. Hitachi bears no responsibility for failure or damage when used beyond the guaranteed ranges. Even within the guaranteed ranges, consider normally foreseeable failure rates or failure modes in semiconductor devices and employ systemic measures such as fail-safes, so that the equipment incorporating Hitachi product does not cause bodily injury, fire or other consequential damage due to operation of the Hitachi product.
5. This product is not designed to be radiation resistant.
6. No one is permitted to reproduce or duplicate, in any form, the whole or part of this document without written approval from Hitachi.
7. Contact Hitachi's sales office for any questions regarding this document or Hitachi semiconductor products.

HITACHI

Hitachi, Ltd.

Semiconductor & Integrated Circuits.
Nippon Bldg., 2-6-2, Ohte-machi, Chiyoda-ku, Tokyo 100-0004, Japan
Tel: Tokyo (03) 3270-2111 Fax: (03) 3270-5109

URL North America : <http://semiconductor.hitachi.com/>
 Europe : <http://www.hitachi-eu.com/hel/ecg>
 Asia (Singapore) : <http://www.has.hitachi.com.sg/grp3/sicd/index.htm>
 Asia (Taiwan) : http://www.hitachi.com.tw/E/Product/SICD_Frame.htm
 Asia (HongKong) : <http://www.hitachi.com.hk/eng/bo/grp3/index.htm>
 Japan : <http://www.hitachi.co.jp/Sicd/indx.htm>

For further information write to:

Hitachi Semiconductor
(America) Inc.
179 East Tasman Drive,
San Jose, CA 95134
Tel: <1> (408) 433-1990
Fax: <1> (408) 433-0223

Hitachi Europe GmbH
Electronic components Group
Dornacher Straße 3
D-85622 Feldkirchen, Munich
Germany
Tel: <49> (89) 9 9180-0
Fax: <49> (89) 9 29 30 00

Hitachi Europe Ltd.
Electronic Components Group.
Whitebrook Park
Lower Cookham Road
Maidenhead
Berkshire SL6 8YA, United Kingdom
Tel: <44> (1628) 585000
Fax: <44> (1628) 778322

Hitachi Asia Pte. Ltd.
16 Collyer Quay #20-00
Hitachi Tower
Singapore 049318
Tel: 535-2100
Fax: 535-1533

Hitachi Asia Ltd.
Taipei Branch Office
3F, Hung Kuo Building, No.167,
Tun-Hwa North Road, Taipei (105)
Tel: <886> (2) 2718-3666
Fax: <886> (2) 2718-8180

Hitachi Asia (Hong Kong) Ltd.
Group III (Electronic Components)
7/F., North Tower, World Finance Centre,
Harbour City, Canton Road, Tsim Sha Tsui,
Kowloon, Hong Kong
Tel: <852> (2) 735 9218
Fax: <852> (2) 730 0281
Telex: 40815 HITEC HX

Copyright ' Hitachi, Ltd., 1999. All rights reserved. Printed in Japan.

HITACHI



LittleDiode supplies new, hard to find or obsolete electronic components and semiconductors all over the world.

With over two million different components listed you are sure to find the part you need.

Feel free to visit us today at our online store:

LittleDiode.com

Looking forward to providing you with the best possible service.