

HD14511B

BCD-to-Seven Segment Latch/Decoder/Driver

The HD14511B BCD-to seven segment latch/decoder/driver provides the functions of a 4-bit storage latch, an 8421 BCD-to-seven segment decoder, and an output drive capability. Lamp test (LT), blanking (BI), and latch enable (LE) inputs are used to test the display, to turn-off or pulse modulate the brightness of the display, and to store a BCD code, respectively. It can be used with seven-segment light emitting diodes (LED), incandescent, fluorescent, gas discharge, or liquid crystal readouts either directly or indirectly. Applications include instrument (e.g., counter, DVM, etc.) display driver, computer/calculator display driver, cockpit display driver, and various clock, watch, and timer uses.

FEATURES

- Quiescent Current = 5nA/pkg typ. @5V
- High-current Sourcing Outputs (Up to 25mA)
- Latch Storage of Code
- Blanking Input
- Lamp Test Provision
- Readout Blanking on all Illegal Input Combinations
- Lamp Intensity Modulation Capability
- Time Share (Multiplexing) Facility
- Supply Voltage Range = 3 to 18V
- Capable of Driving One Low-power Schottky TTL Load Over the Rated Temperature Range

LOGIC DIAGRAM

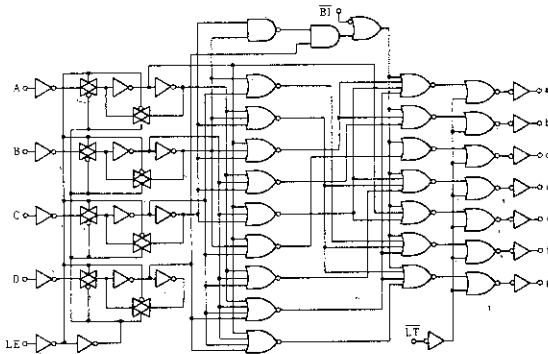

MAXIMUM RATINGS (Voltages referenced to V_{SS})

Characteristic	Symbol	Value	Unit
DC Supply Voltage	V_{DD}	-0.5 ~ +18	V
Input Voltage	V_{in}	-0.5 ~ $V_{DD} + 0.5$	V
Output Voltage	V_{out}	-0.5 ~ $V_{DD} + 0.5$	V
DC Current Drain per Input	I_{in}	10	mA
Operating Temperature Range	T_A	-40 ~ +85	°C
Storage Temperature Range	T_{stg}	-65 ~ +150	°C
Maximum Output Drive Current	$I_{OH\ max}$	25	mA
Maximum Continuous Output Power*	$P_{OH\ max}$	50	mW
Power Dissipation	P_D	300	mW

* $P_{OH\ max} \sim I_{OH} (V_{DD} - V_{OH})$

PIN ARRANGEMENT

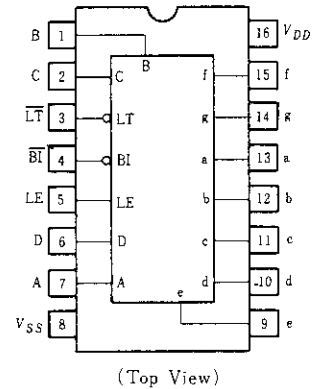

TRUTH TABLE

Inputs				Outputs								
LE	BI	LT	D C B A	a	b	c	d	e	f	g	Display	
x	x	0	x	x	x	1	1	1	1	1	1	8
x	0	1	x	x	x	0	0	0	0	0	0	Blank
0	1	1	0	0	0	1	1	1	1	1	0	0
0	1	1	0	0	1	0	1	1	0	0	0	1
0	1	1	0	1	0	1	1	0	1	0	1	2
0	1	1	0	1	1	1	1	1	0	0	1	3
0	1	1	0	1	0	0	0	1	1	0	1	4
0	1	1	0	1	0	1	1	0	1	1	1	5
0	1	1	0	1	1	0	0	0	1	1	1	6
0	1	1	0	1	1	1	1	1	0	0	0	7
0	1	1	1	0	0	0	1	1	1	1	1	8
0	1	1	1	0	0	1	1	1	0	0	1	9
0	1	1	1	0	1	0	0	0	0	0	0	Blank
0	1	1	1	1	0	1	0	0	0	0	0	Blank
0	1	1	1	1	0	0	0	0	0	0	0	Blank
0	1	1	1	1	0	1	0	0	0	0	0	Blank
0	1	1	1	1	1	0	0	0	0	0	0	Blank
0	1	1	1	1	1	1	0	0	0	0	0	Blank
1	1	1	x	x	x	x	x	x	x	x	x	*

x = Don't Care

* Depends upon the BCD code previously applied when LE=0

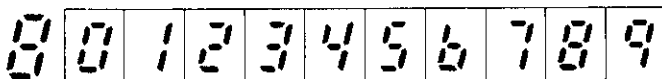

ELECTRICAL CHARACTERISTICS

Characteristic	Symbol	$V_{DD}(V)$	Test Conditions	-40°C		25°C			85°C		Unit
				min	max	min	typ	max	min	max	
Output Voltage	V_{OL}	5.0	$V_{in} = V_{DD}$ or 0	-	0.05	-	0	0.05	-	0.05	V
		10		-	0.05	-	0	0.05	-	0.05	
		15		-	0.05	-	0	0.05	-	0.05	
	V_{OH}	5.0	$V_{in} = 0$ or V_{DD}	4.1	-	4.1	5.0	-	4.1	-	V
		10		9.1	-	9.1	10	-	9.1	-	
		15		14.1	-	14.1	15	-	14.1	-	
Input Voltage	V_{IL}	5.0	$V_{out} = 3.8$ or $0.5V$	-	1.5	-	2.25	1.5	-	1.5	V
		10	$V_{out} = 8.8$ or $1.0V$	-	3.0	-	4.50	3.0	-	3.0	
		15	$V_{out} = 13.8$ or $1.5V$	-	4.0	-	6.75	4.0	-	4.0	
	V_{IH}	5.0	$V_{out} = 0.5$ or $3.8V$	3.5	-	3.5	2.75	-	3.5	-	V
		10	$V_{out} = 1.0$ or $8.8V$	7.0	-	7.0	5.50	-	7.0	-	
		15	$V_{out} = 1.5$ or $13.8V$	11.0	-	11.0	8.25	-	11.0	-	
Output Drive Voltage	V_{OH}	5.0	$I_{OH} = 0\text{mA}$	4.10	-	4.10	4.57	-	4.1	-	V
			$I_{OH} = 5\text{mA}$	-	-	-	4.24	-	-	-	
			$I_{OH} = 10\text{mA}$	3.60	-	3.60	4.12	-	3.3	-	
			$I_{OH} = 15\text{mA}$	-	-	-	3.94	-	-	-	
			$I_{OH} = 20\text{mA}$	2.80	-	2.80	3.75	-	2.5	-	
			$I_{OH} = 25\text{mA}$	-	-	-	3.54	-	-	-	
		10	$I_{OH} = 0\text{mA}$	9.10	-	9.10	9.58	-	9.1	-	
			$I_{OH} = 5\text{mA}$	-	-	-	9.26	-	-	-	
			$I_{OH} = 10\text{mA}$	8.75	-	8.75	9.17	-	8.45	-	
			$I_{OH} = 15\text{mA}$	-	-	-	9.04	-	-	-	
			$I_{OH} = 20\text{mA}$	8.10	-	8.10	8.90	-	7.8	-	
			$I_{OH} = 25\text{mA}$	-	-	-	8.75	-	-	-	
		15	$I_{OH} = 0\text{mA}$	14.1	-	14.1	14.59	-	14.1	-	
			$I_{OH} = 5\text{mA}$	-	-	-	14.27	-	-	-	
			$I_{OH} = 10\text{mA}$	13.75	-	13.75	14.18	-	13.45	-	
			$I_{OH} = 15\text{mA}$	-	-	-	14.07	-	-	-	
			$I_{OH} = 20\text{mA}$	13.1	-	13.1	13.95	-	12.8	-	
			$I_{OH} = 25\text{mA}$	-	-	-	13.80	-	-	-	
Output Drive Current	I_{OL}	5.0	$V_{OL} = 0.4V$	0.52	-	0.44	0.88	-	0.36	-	mA
		10	$V_{OL} = 0.5V$	1.3	-	1.1	2.25	-	0.9	-	
		15	$V_{OL} = 1.5V$	3.6	-	3.0	8.8	-	2.4	-	
Input Current	I_{in}	15		-	± 0.3	-	± 0.0001	± 0.3	-	± 1.0	μA
Input Capacitance	C_{in}		$V_{in} = 0$	-	-	-	5.0	7.5	-	-	pF
Quiescent Current	I_{DD}	5.0	Zero Signal, per Package	-	20	-	0.005	20	-	150	μA
		10		-	40	-	0.010	40	-	300	
		15		-	80	-	0.015	80	-	600	
Total Supply Current*	I_T	5.0	Dynamic + I_{DD} , per Gate $C_L = 50\text{pF}$, $f = 1\text{kHz}$	-	-	-	1.9	-	-	-	μA
		10		-	-	-	3.8	-	-	-	
		15		-	-	-	5.7	-	-	-	

* To calculate total supply current at frequency other than 1kHz.

 $\text{@ } V_{DD} = 5.0V \quad I_T = (1.9\mu\text{A}/\text{kHz})f + I_{DD}$
 $\text{@ } V_{DD} = 10V \quad I_T = (3.8\mu\text{A}/\text{kHz})f + I_{DD}$
 $\text{@ } V_{DD} = 15V \quad I_T = (5.7\mu\text{A}/\text{kHz})f + I_{DD}$

■ SWITCHING CHARACTERISTICS ($C_L=50\text{pF}$, $T_a=25^\circ\text{C}$)

Characteristic	Symbol	V_{DD} (V)	min	typ	max	Unit	
Output Rise Time	t_r	5.0	—	40	80	ns	
		10	—	30	60		
		15	—	25	50		
Output Fall Time	t_f	5.0	—	125	250	ns	
		10	—	75	150		
		15	—	65	130		
Propagation Delay Time	Data	t_{PLH}	5.0	—	640	1280	ns
			10	—	250	500	
			15	—	175	350	
		t_{PHL}	5.0	—	720	1440	ns
			10	—	290	580	
			15	—	200	400	
	Blank	t_{PLH}	5.0	—	380	750	ns
			10	—	130	260	
			15	—	100	200	
		t_{PHL}	5.0	—	485	970	ns
			10	—	200	400	
			15	—	160	320	
Lamp Test	t_{PLH}	5.0	—	313	625	ns	
		10	—	125	250		
		15	—	90	180		
	t_{PHL}	5.0	—	313	625	ns	
		10	—	125	250		
		15	—	90	180		
Setup Time	t_{setup}	5.0	180	90	—	ns	
		10	76	38	—		
		15	40	20	—		
Hold Time	t_{hold}	5.0	0	-90	—	ns	
		10	0	-38	—		
		15	0	-20	—		
Latch Enable Pulse Width	PW_{LE}	5.0	520	260	—	ns	
		10	220	110	—		
		15	130	65	—		

■ POWER DISSIPATION SIGNAL WAVEFORMS

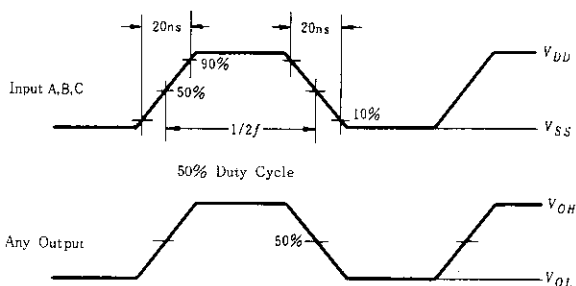

Input LE low, and Inputs \overline{D} , \overline{BI} and \overline{LT} high, f in respect to a system clock. All outputs connected to respective C_L loads.

■ DYNAMIC SIGNAL WAVEFORMS

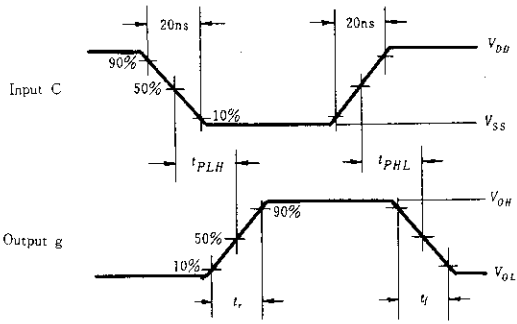

Inputs D and LE low, and Inputs A, B, \overline{BI} and \overline{LT} high.

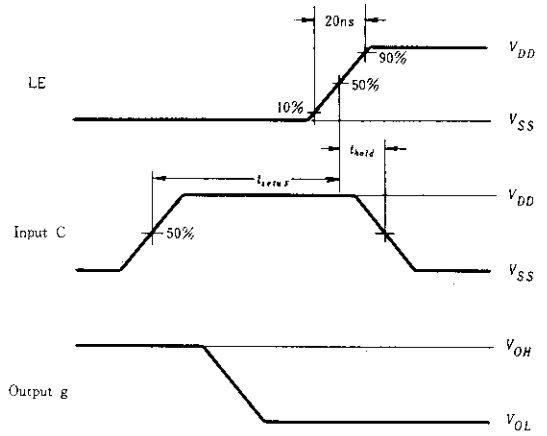

Input D low, Inputs A, B, \overline{BI} and \overline{LT} high.

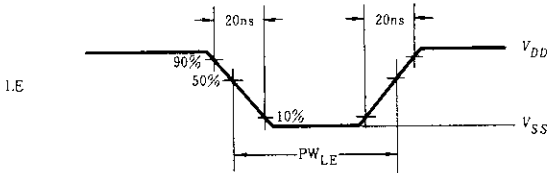

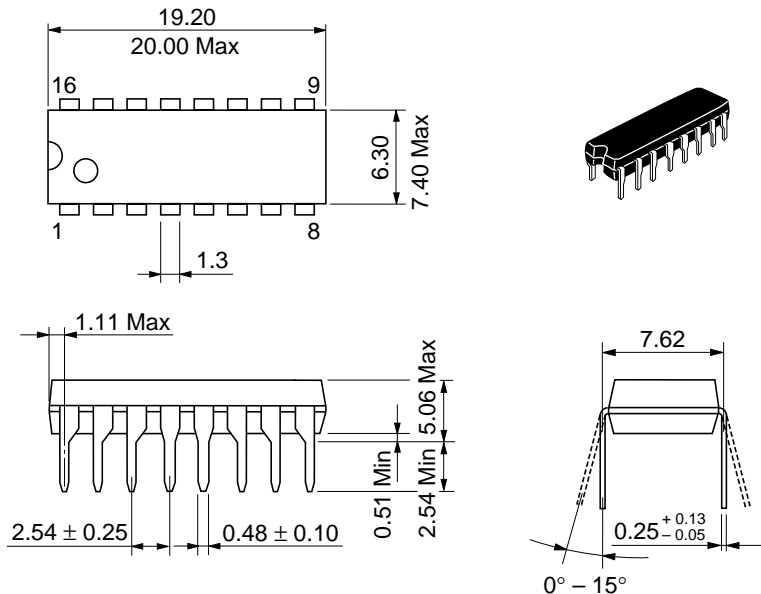

Hitachi Code	DP-16
JEDEC	Conforms
EIAJ	Conforms
Weight (reference value)	1.07 g

Cautions

1. Hitachi neither warrants nor grants licenses of any rights of Hitachi's or any third party's patent, copyright, trademark, or other intellectual property rights for information contained in this document. Hitachi bears no responsibility for problems that may arise with third party's rights, including intellectual property rights, in connection with use of the information contained in this document.
2. Products and product specifications may be subject to change without notice. Confirm that you have received the latest product standards or specifications before final design, purchase or use.
3. Hitachi makes every attempt to ensure that its products are of high quality and reliability. However, contact Hitachi's sales office before using the product in an application that demands especially high quality and reliability or where its failure or malfunction may directly threaten human life or cause risk of bodily injury, such as aerospace, aeronautics, nuclear power, combustion control, transportation, traffic, safety equipment or medical equipment for life support.
4. Design your application so that the product is used within the ranges guaranteed by Hitachi particularly for maximum rating, operating supply voltage range, heat radiation characteristics, installation conditions and other characteristics. Hitachi bears no responsibility for failure or damage when used beyond the guaranteed ranges. Even within the guaranteed ranges, consider normally foreseeable failure rates or failure modes in semiconductor devices and employ systemic measures such as fail-safes, so that the equipment incorporating Hitachi product does not cause bodily injury, fire or other consequential damage due to operation of the Hitachi product.
5. This product is not designed to be radiation resistant.
6. No one is permitted to reproduce or duplicate, in any form, the whole or part of this document without written approval from Hitachi.
7. Contact Hitachi's sales office for any questions regarding this document or Hitachi semiconductor products.

HITACHI

Hitachi, Ltd.

Semiconductor & Integrated Circuits.
Nippon Bldg., 2-6-2, Ohte-machi, Chiyoda-ku, Tokyo 100-0004, Japan
Tel: Tokyo (03) 3270-2111 Fax: (03) 3270-5109

URL North America : <http://semiconductor.hitachi.com/>
 Europe : <http://www.hitachi-eu.com/hel/ecg>
 Asia (Singapore) : <http://www.has.hitachi.com.sg/grp3/sicd/index.htm>
 Asia (Taiwan) : http://www.hitachi.com.tw/E/Product/SICD_Frame.htm
 Asia (HongKong) : <http://www.hitachi.com.hk/eng/bo/grp3/index.htm>
 Japan : <http://www.hitachi.co.jp/Sicd/indx.htm>

For further information write to:

Hitachi Semiconductor
(America) Inc.
179 East Tasman Drive,
San Jose, CA 95134
Tel: <1> (408) 433-1990
Fax: <1> (408) 433-0223

Hitachi Europe GmbH
Electronic components Group
Dornacher Straße 3
D-85622 Feldkirchen, Munich
Germany
Tel: <49> (89) 9 9180-0
Fax: <49> (89) 9 29 30 00

Hitachi Europe Ltd.
Electronic Components Group.
Whitebrook Park
Lower Cookham Road
Maidenhead
Berkshire SL6 8YA, United Kingdom
Tel: <44> (1628) 585000
Fax: <44> (1628) 778322

Hitachi Asia Pte. Ltd.
16 Collyer Quay #20-00
Hitachi Tower
Singapore 049318
Tel: 535-2100
Fax: 535-1533

Hitachi Asia Ltd.
Taipei Branch Office
3F, Hung Kuo Building, No.167,
Tun-Hwa North Road, Taipei (105)
Tel: <886> (2) 2718-3666
Fax: <886> (2) 2718-8180

Hitachi Asia (Hong Kong) Ltd.
Group III (Electronic Components)
7/F., North Tower, World Finance Centre,
Harbour City, Canton Road, Tsim Sha Tsui,
Kowloon, Hong Kong
Tel: <852> (2) 735 9218
Fax: <852> (2) 730 0281
Telex: 40815 HITEC HX

Copyright ' Hitachi, Ltd., 1999. All rights reserved. Printed in Japan.

HITACHI



LittleDiode supplies new, hard to find or obsolete electronic components and semiconductors all over the world.

With over two million different components listed you are sure to find the part you need.

Feel free to visit us today at our online store:

LittleDiode.com

Looking forward to providing you with the best possible service.