

HD14022B

Octal Counter/Divider

The HD14022B is a four-stage Johnson octal counter with built-in code converter. High speed operation and spike-free outputs are obtained by use of a Johnson octal counter design. The eight decoded outputs are normally low, and go high only at their appropriate octal time period. The output changes occur on the positive-going edge of the clock pulse. This part can be used in frequency division applications as well as octal counter or octal decode display applications.

FEATURES

- Quiescent Current = 5nA/pkg typ. @5V
- Supply Voltage Range = 3 to 18V
- Capable of Driving One Low-power Schottky TTL Load Over the Rated Temperature Range
- Pin-for-Pin Replacement for CD4022B and HD14022B

PIN ARRANGEMENT

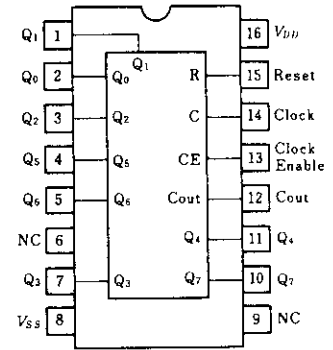

(Top View)

LOGIC DIAGRAM

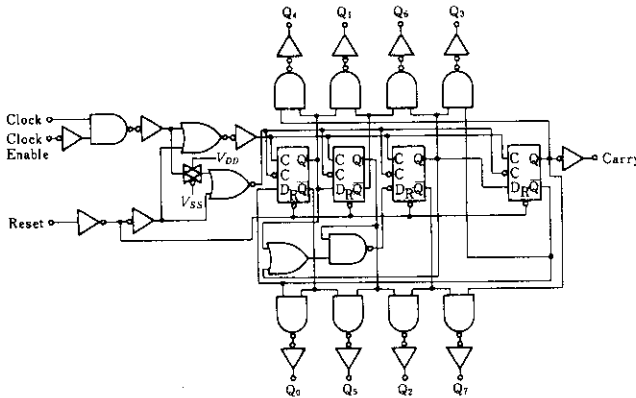

TRUTH TABLE

Clock	Clock Enable	Reset	Output n
L	x	L	n
x	H	L	n
↗	L	L	n + 1
↘	x	L	n
H	↗	L	n + 1
x	↘	L	n
x	x	H	Q ₀

x : Don't Care
 n < 4... Carry = H
 n ≥ 4... Carry = L

Typical Output Source and Output Sink Characteristics Test Circuit

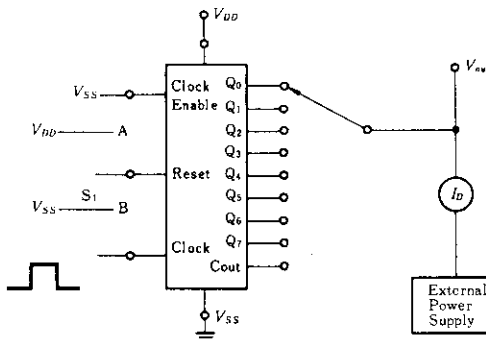

	I_{OL}	I_{OH}
Outputs	(S ₁ → A)	Clock to desired Output (S ₁ to B)
Carry	Clock to Q ₅ thru Q ₇ (S ₁ to B)	S ₁ → A
V _{CS}	V _{DD}	-V _{DD}
V _{DS}	V _{ext}	V _{ext} - V _{DD}

■ ELECTRICAL CHARACTERISTICS

Characteristic	Symbol	V _{DD} (V)	Test Conditions	-40°C		25°C			85°C		Unit
				min	max	min	typ	max	min	max	
Output Voltage	V _{OL}	5.0	V _{in} = V _{DD} or 0	—	0.05	—	0	0.05	—	0.05	V
		10		—	0.05	—	0	0.05	—	0.05	
		15		—	0.05	—	0	0.05	—	0.05	
	V _{OH}	5.0	V _{in} = 0 or V _{DD}	4.95	—	4.95	5.0	—	4.95	—	V
		10		9.95	—	9.95	10	—	9.95	—	
		15		14.95	—	14.95	15	—	14.95	—	
Input Voltage	V _{IL}	5.0	V _{out} = 4.5 or 0.5V	—	1.5	—	2.25	1.5	—	1.5	V
		10	V _{out} = 9.0 or 1.0V	—	3.0	—	4.50	3.0	—	3.0	
		15	V _{out} = 13.5 or 1.5V	—	4.0	—	6.75	4.0	—	4.0	
	V _{IH}	5.0	V _{out} = 0.5 or 4.5V	3.5	—	3.5	2.75	—	3.5	—	V
		10	V _{out} = 1.0 or 9.0V	7.0	—	7.0	5.50	—	7.0	—	
		15	V _{out} = 1.5 or 13.5V	11.0	—	11.0	8.25	—	11.0	—	
Output Drive Current	I _{OH}	5.0	V _{OH} = 2.5V	-1.0	—	-0.8	-1.7	—	-0.6	—	mA
		5.0	V _{OH} = 4.6V	-0.2	—	-0.16	-0.36	—	-0.12	—	
		10	V _{OH} = 9.5V	-0.5	—	-0.4	-0.9	—	-0.3	—	
		15	V _{OH} = 13.5V	-1.4	—	-1.2	-3.5	—	-1.0	—	
	I _{OL}	5.0	V _{OL} = 0.4V	0.52	—	0.44	0.88	—	0.36	—	mA
		10	V _{OL} = 0.5V	1.3	—	1.1	2.25	—	0.9	—	
15		V _{OL} = 1.5V	3.6	—	3.0	8.8	—	2.4	—		
Input Current	I _n	15		—	±0.3	—	±0.00001	±0.3	—	±1.0	μA
Input Capacitance	C _{in}		V _{in} = 0	—	—	—	5.0	7.5	—	—	pF
Quiescent Current	I _{DD}	5.0	Zero Signal, per Package	—	20	—	0.005	20	—	150	μA
		10		—	40	—	0.010	40	—	300	
		15		—	80	—	0.015	80	—	600	
Total Supply Current*	I _T	5.0	Dynamic + I _{DD} , per Gate, C _L = 50pF, f = 1 kHz	—	—	—	0.28	—	—	—	μA
		10		—	—	—	0.56	—	—	—	
		15		—	—	—	0.85	—	—	—	

* To calculate total supply current at frequency other than 1kHz.

@ V_{DD} = 5.0V I_T = (0.28μA/kHz)f + I_{DD}, @ V_{DD} = 10V I_T = (0.56μA/kHz)f + I_{DD}, @ V_{DD} = 15V I_T = (0.85μA/kHz)f + I_{DD}.

■ POWER DISSIPATION TEST CIRCUIT

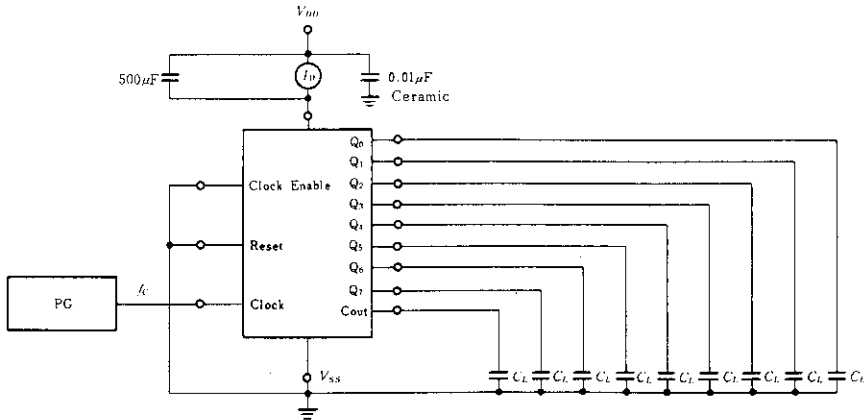

SWITCHING CHARACTERISTICS ($C_L = 50\text{pF}$, $T_a = 25^\circ\text{C}$)

Characteristic		Symbol	V_{DD} (V)	min	typ	max	Unit
Output Rise Time		t_r	5.0	—	180	400	ns
			10	—	90	200	
			15	—	65	160	
Output Fall Time		t_f	5.0	—	100	200	ns
			10	—	50	100	
			15	—	37	80	
Propagation Delay Time	Reset to Decode Out	t_{PLH} t_{PHL}	5.0	—	500	1000	ns
			10	—	230	460	
			15	—	140	350	
	Clock to Cout		5.0	—	400	800	
			10	—	150	350	
			15	—	100	250	
	Clock to Decode Out	5.0	—	500	1000		
		10	—	230	460		
		15	—	140	350		
	Reset to Cout	t_{PLH}	5.0	—	400	800	
			10	—	150	350	
			15	—	100	250	
Clock Pulse Width	PW_C	5.0	250	100	—	ns	
		10	100	42	—		
		15	75	30	—		
Clock Frequency	PRF	5.0	—	5.0	2.0	MHz	
		10	—	12	5.0		
		15	—	16	6.7		
Reset Pulse Width	PW_R	5.0	500	200	—	ns	
		10	250	100	—		
		15	190	75	—		
Reset Removal Time	t_{rem}	5.0	750	300	—	ns	
		10	275	100	—		
		15	210	80	—		
Clock Pulse Rise and Fall Time	t_r, t_f	5.0	No Limit				
		10					
		15					
Clock Enable Setup Time	t_{setup}	5.0	700	175	—	ns	
		10	300	75	—		
		15	225	52	—		
Clock Enable Removal Time	t_{rem}	5.0	700	260	—	ns	
		10	300	100	—		
		15	225	70	—		

■ DYNAMIC SIGNAL WAVEFORMS

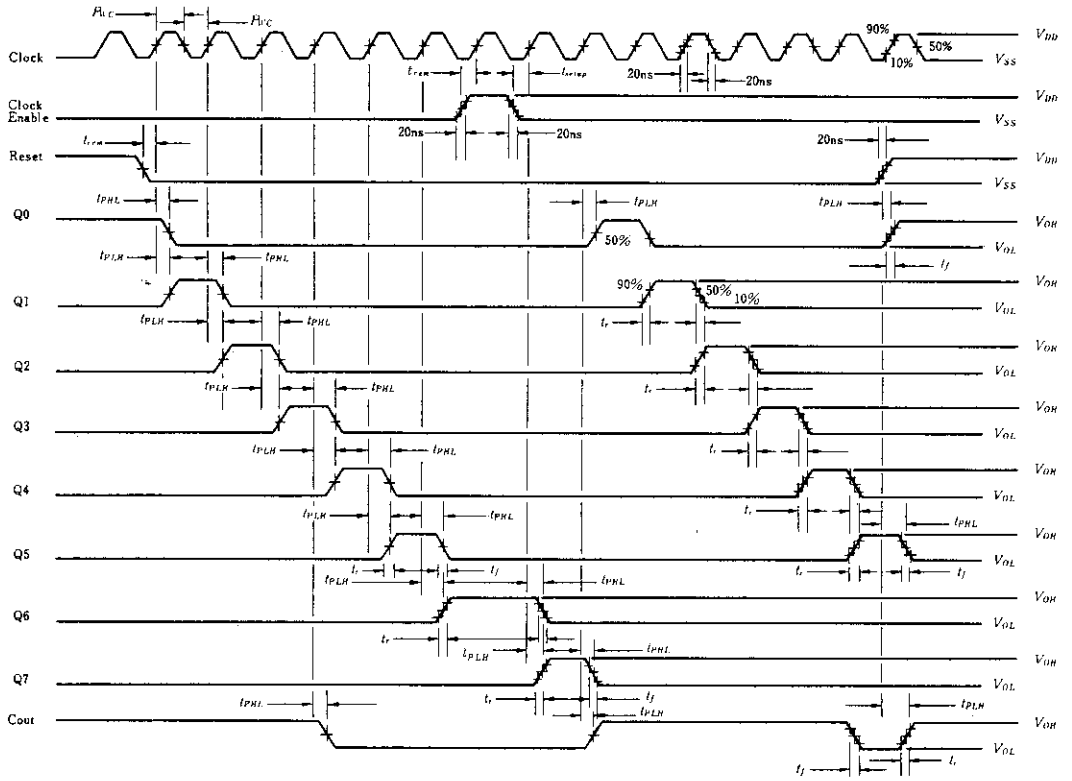

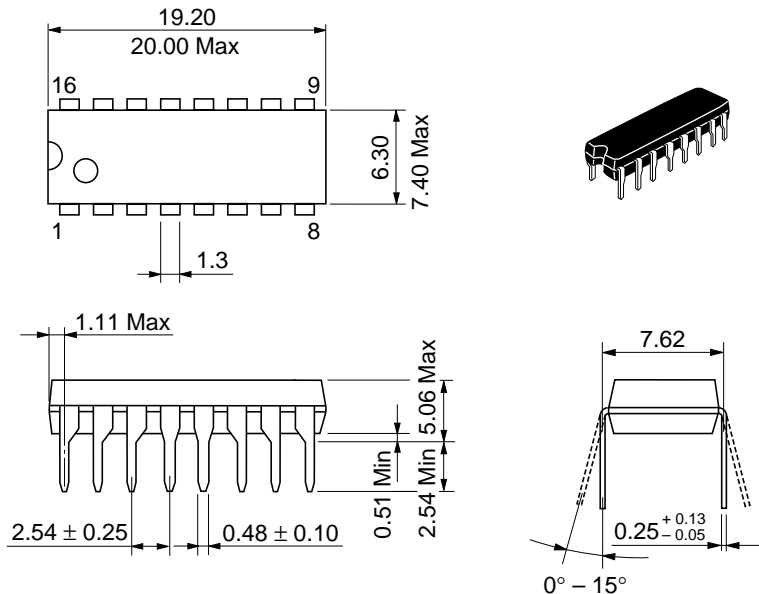

Hitachi Code	DP-16
JEDEC	Conforms
EIAJ	Conforms
Weight (reference value)	1.07 g

Cautions

1. Hitachi neither warrants nor grants licenses of any rights of Hitachi's or any third party's patent, copyright, trademark, or other intellectual property rights for information contained in this document. Hitachi bears no responsibility for problems that may arise with third party's rights, including intellectual property rights, in connection with use of the information contained in this document.
2. Products and product specifications may be subject to change without notice. Confirm that you have received the latest product standards or specifications before final design, purchase or use.
3. Hitachi makes every attempt to ensure that its products are of high quality and reliability. However, contact Hitachi's sales office before using the product in an application that demands especially high quality and reliability or where its failure or malfunction may directly threaten human life or cause risk of bodily injury, such as aerospace, aeronautics, nuclear power, combustion control, transportation, traffic, safety equipment or medical equipment for life support.
4. Design your application so that the product is used within the ranges guaranteed by Hitachi particularly for maximum rating, operating supply voltage range, heat radiation characteristics, installation conditions and other characteristics. Hitachi bears no responsibility for failure or damage when used beyond the guaranteed ranges. Even within the guaranteed ranges, consider normally foreseeable failure rates or failure modes in semiconductor devices and employ systemic measures such as fail-safes, so that the equipment incorporating Hitachi product does not cause bodily injury, fire or other consequential damage due to operation of the Hitachi product.
5. This product is not designed to be radiation resistant.
6. No one is permitted to reproduce or duplicate, in any form, the whole or part of this document without written approval from Hitachi.
7. Contact Hitachi's sales office for any questions regarding this document or Hitachi semiconductor products.

HITACHI

Hitachi, Ltd.

Semiconductor & Integrated Circuits.
Nippon Bldg., 2-6-2, Ohte-machi, Chiyoda-ku, Tokyo 100-0004, Japan
Tel: Tokyo (03) 3270-2111 Fax: (03) 3270-5109

URL North America : <http://semiconductor.hitachi.com/>
 Europe : <http://www.hitachi-eu.com/hel/ecg>
 Asia (Singapore) : <http://www.has.hitachi.com.sg/grp3/sicd/index.htm>
 Asia (Taiwan) : http://www.hitachi.com.tw/E/Product/SICD_Frame.htm
 Asia (HongKong) : <http://www.hitachi.com.hk/eng/bo/grp3/index.htm>
 Japan : <http://www.hitachi.co.jp/Sicd/indx.htm>

For further information write to:

Hitachi Semiconductor
(America) Inc.
179 East Tasman Drive,
San Jose, CA 95134
Tel: <1> (408) 433-1990
Fax: <1>(408) 433-0223

Hitachi Europe GmbH
Electronic components Group
Dornacher Straße 3
D-85622 Feldkirchen, Munich
Germany
Tel: <49> (89) 9 9180-0
Fax: <49> (89) 9 29 30 00

Hitachi Europe Ltd.
Electronic Components Group.
Whitebrook Park
Lower Cookham Road
Maidenhead
Berkshire SL6 8YA, United Kingdom
Tel: <44> (1628) 585000
Fax: <44> (1628) 778322

Hitachi Asia Pte. Ltd.
16 Collyer Quay #20-00
Hitachi Tower
Singapore 049318
Tel: 535-2100
Fax: 535-1533

Hitachi Asia Ltd.
Taipei Branch Office
3F, Hung Kuo Building, No.167,
Tun-Hwa North Road, Taipei (105)
Tel: <886> (2) 2718-3666
Fax: <886> (2) 2718-8180

Hitachi Asia (Hong Kong) Ltd.
Group III (Electronic Components)
7/F., North Tower, World Finance Centre,
Harbour City, Canton Road, Tsim Sha Tsui,
Kowloon, Hong Kong
Tel: <852> (2) 735 9218
Fax: <852> (2) 730 0281
Telex: 40815 HITEC HX

Copyright ' Hitachi, Ltd., 1999. All rights reserved. Printed in Japan.

HITACHI



LittleDiode supplies new, hard to find or obsolete electronic components and semiconductors all over the world.

With over two million different components listed you are sure to find the part you need.

Feel free to visit us today at our online store:

LittleDiode.com

Looking forward to providing you with the best possible service.