

HD14020B

14-bit Binary Counter

The HD14020B 14-stage binary counter is designed with an input wave shaping circuit and 14 stages of ripple-carry binary counter. The device advances the count on the negative-going edge of the clock pulse. Applications include time delay circuits, counter controls, and frequency-dividing circuits.

FEATURES

- Supply Voltage Range = 3 to 18V
- Capable of Driving One Low-power Schottky TTL Load Over the Rated Temperature Range
- Common Reset Line
- 13MHz typ. Counting Rate @15V
- Pin-for-Pin Replacement for CD4020B and MC14020B

PIN ARRANGEMENT

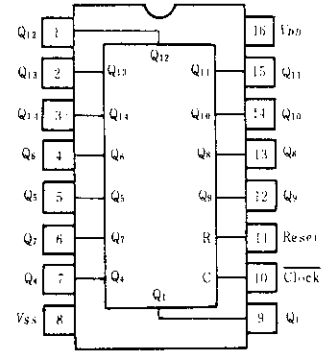

(Top View)

LOGIC DIAGRAM

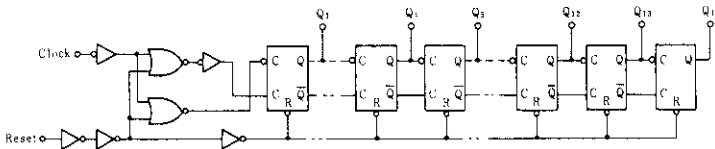

TRUTH TABLE

| Clock | Reset | Outputs State |
|-------|-------|-----------------------|
| | 0 | No Change |
| | 0 | Advance to next state |
| x | 1 | All Outputs are low |

x : Don't Care

TIMING DIAGRAM

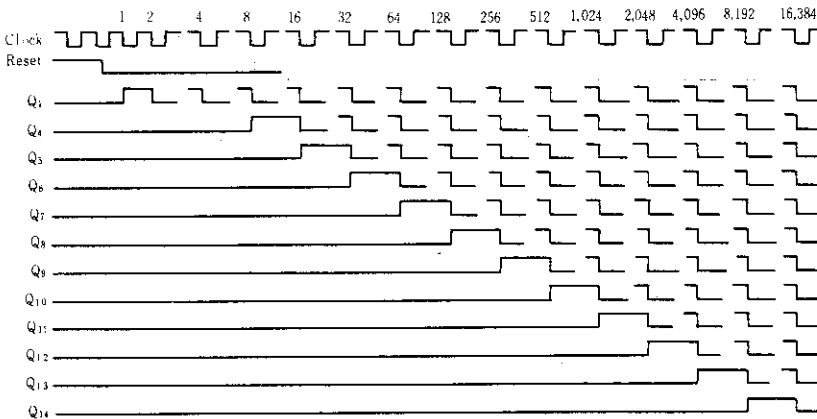

ELECTRICAL CHARACTERISTICS

| Characteristic | Symbol | Test Conditions | -40°C | | 25°C | | | 85°C | | Unit | | | | | |
|-----------------------|----------|--------------------|----------------------------------|-----------------------------|---------------|---------------|---------------|---------------|-----------|-------|---------------|-----------|------|-----------|---------|
| | | | min | max | min | typ | max | min | max | | | | | | |
| Output Voltage | V_{OL} | $V_{DD}(V)$ 5.0 | $V_{in}=V_{DD}$ or 0 | — | 0.05 | — | 0 | 0.05 | — | 0.05 | V | | | | |
| | | 10 | | — | 0.05 | — | 0 | 0.05 | — | 0.05 | | | | | |
| | | 15 | | — | 0.05 | — | 0 | 0.05 | — | 0.05 | | | | | |
| | V_{OH} | 5.0 | | $V_{in}=0$ or V_{DD} | 4.95 | — | 4.95 | 5.0 | — | 4.95 | — | V | | | |
| | | 10 | | | 9.95 | — | 9.95 | 10 | — | 9.95 | — | | | | |
| | | 15 | | | 14.95 | — | 14.95 | 15 | — | 14.95 | — | | | | |
| Input Voltage | V_{IL} | 5.0 | $V_{out}=4.5$ or 0.5V | | — | 1.5 | — | 2.25 | 1.5 | — | 1.5 | V | | | |
| | | 10 | | | — | 3.0 | — | 4.50 | 3.0 | — | 3.0 | | | | |
| | | 15 | | | — | 4.0 | — | 6.75 | 4.0 | — | 4.0 | | | | |
| | V_{IH} | 5.0 | | $V_{out}=0.5$ or 4.5V | 3.5 | — | 3.5 | 2.75 | — | 3.5 | — | V | | | |
| | | 10 | | | 7.0 | — | 7.0 | 5.50 | — | 7.0 | — | | | | |
| | | 15 | | | 11.0 | — | 11.0 | 8.25 | — | 11.0 | — | | | | |
| Output Drive Current | I_{OH} | 5.0 | $V_{OH}=2.5V$ | | -1.0 | — | -0.8 | -1.7 | — | -0.6 | — | mA | | | |
| | | 5.0 | | | $V_{OH}=4.6V$ | -0.2 | — | -0.16 | -0.36 | — | -0.12 | | — | | |
| | | 10 | | | | $V_{OH}=9.5V$ | -0.5 | — | -0.4 | -0.9 | — | | -0.3 | — | |
| | 15 | $V_{OH}=13.5V$ | | -1.4 | | | — | -1.2 | -3.5 | — | -1.0 | — | | | |
| | I_{OL} | | | 5.0 | | | $V_{OL}=0.4V$ | 0.52 | — | 0.44 | 0.88 | — | 0.36 | — | mA |
| | | | | 10 | | | | $V_{OL}=0.5V$ | 1.3 | — | 1.1 | 2.25 | — | 0.9 | |
| 15 | | | $V_{OL}=1.5V$ | 3.6 | | | | | — | 3.0 | 8.8 | — | 2.4 | — | |
| Input Current | I_{in} | | | 15 | — | | | | ± 0.3 | — | ± 0.00001 | ± 0.3 | — | ± 1.0 | μA |
| Input Capacitance | C_{in} | | | $V_{in}=0$ | — | — | | | — | 5.0 | 7.5 | — | — | pF | |
| Quiescent Current | I_{DD} | 5.0 | | Zero Signal, per Package | — | 20 | | | — | 0.005 | 20 | — | 150 | μA | |
| | | 10 | | | — | 40 | — | | 0.010 | 40 | — | 300 | | | |
| | | 15 | | | — | 80 | — | 0.015 | 80 | — | 600 | | | | |
| Total Supply Current* | I_T | 5.0 | Dynamic + I_{DD} , per Gate | | — | — | — | 0.43 | — | — | — | μA | | | |
| | | 10 | | | — | — | — | 0.86 | — | — | — | | | | |
| | | 15 | | | — | — | — | 1.45 | — | — | — | | | | |

* To calculate total supply current at frequency other than 1kHz.
 @ $V_{DD}=5.0V$ $I_T=10.42\mu A/kHz$ / $f + I_{DD}$, @ $V_{DD}=10V$ $I_T=10.85\mu A/kHz$ / $f + I_{DD}$, @ $V_{DD}=15V$ $I_T=11.43\mu A/kHz$ / $f + I_{DD}$

POWER DISSIPATION TEST CIRCUIT AND WAVEFORM

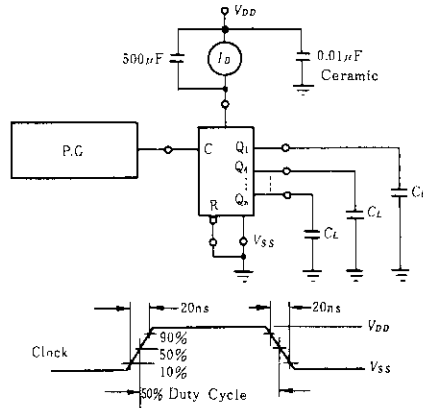

■ SWITCHING CHARACTERISTICS ($C_L=50\text{pF}$, $T_a=25^\circ\text{C}$)

| Characteristic | | Symbol | $V_{DD}(\text{V})$ | min | typ | max | Unit |
|--------------------------------|------------------------|------------|--------------------|----------|-----|------|---------------|
| Output Rise Time | | t_r | 5.0 | — | 180 | 400 | ns |
| | | | 10 | — | 90 | 200 | |
| | | | 15 | — | 65 | 160 | |
| Output Fall Time | | t_f | 5.0 | — | 100 | 200 | ns |
| | | | 10 | — | 50 | 100 | |
| | | | 15 | — | 37 | 80 | |
| Propagation Delay Time | Clock to Q_1 | t_{PLH} | 5.0 | — | 400 | 750 | ns |
| | | | 10 | — | 170 | 300 | |
| | | | 15 | — | 120 | 230 | |
| | Clock to $Q_{1\bar{}}$ | t_{PHL} | 5.0 | — | 2.8 | 8.4 | μs |
| | | | 10 | — | 1.0 | 3.0 | |
| | | | 15 | — | 0.6 | 2.5 | |
| | Reset to Q_s | t_{PHL} | 5.0 | — | 595 | 3500 | ns |
| | | | 10 | — | 230 | 900 | |
| | | | 15 | — | 180 | 680 | |
| Clock Pulse Width | | PW_C | 5.0 | 500 | 140 | — | ns |
| | | | 10 | 165 | 55 | — | |
| | | | 15 | 125 | 38 | — | |
| Clock Pulse Frequency | | PRF | 5.0 | — | 3.5 | 1.0 | MHz |
| | | | 10 | — | 9.0 | 3.0 | |
| | | | 15 | — | 13 | 4.0 | |
| Clock Pulse Rise and Fall Time | | t_r, t_f | 5.0 | No Limit | | | |
| | | | 10 | | | | |
| | | | 15 | | | | |
| Reset Pulse Width | | PW_R | 5.0 | 3000 | 320 | — | ns |
| | | | 10 | 550 | 120 | — | |
| | | | 15 | 420 | 80 | — | |

■ SWITCHING TIME TEST CIRCUIT

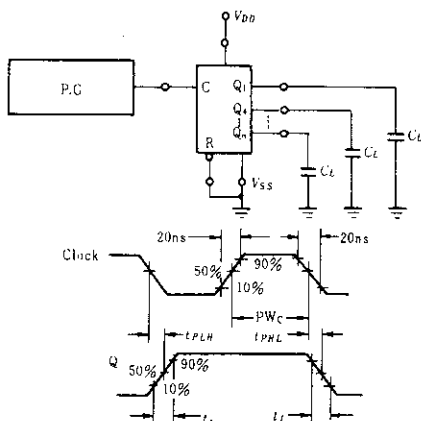

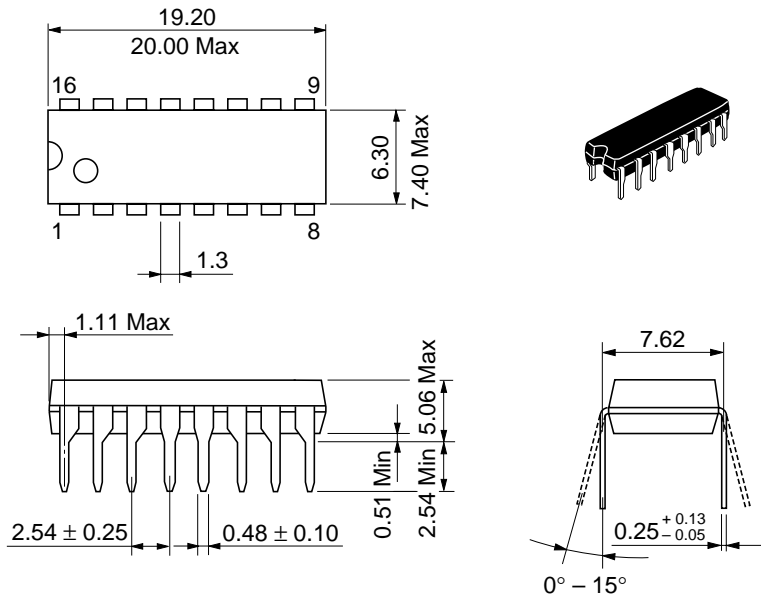

| | |
|--------------------------|----------|
| Hitachi Code | DP-16 |
| JEDEC | Conforms |
| EIAJ | Conforms |
| Weight (reference value) | 1.07 g |

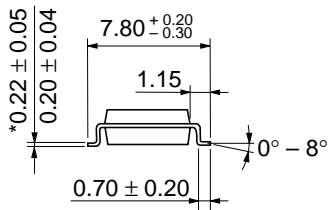

*Dimension including the plating thickness
Base material dimension

| | |
|--------------------------|----------|
| Hitachi Code | FP-16DA |
| JEDEC | — |
| EIAJ | Conforms |
| Weight (reference value) | 0.24 g |



*Dimension including the plating thickness
Base material dimension

| | |
|--------------------------|----------|
| Hitachi Code | FP-16DN |
| JEDEC | Conforms |
| EIAJ | Conforms |
| Weight (reference value) | 0.15 g |

Cautions

1. Hitachi neither warrants nor grants licenses of any rights of Hitachi's or any third party's patent, copyright, trademark, or other intellectual property rights for information contained in this document. Hitachi bears no responsibility for problems that may arise with third party's rights, including intellectual property rights, in connection with use of the information contained in this document.
2. Products and product specifications may be subject to change without notice. Confirm that you have received the latest product standards or specifications before final design, purchase or use.
3. Hitachi makes every attempt to ensure that its products are of high quality and reliability. However, contact Hitachi's sales office before using the product in an application that demands especially high quality and reliability or where its failure or malfunction may directly threaten human life or cause risk of bodily injury, such as aerospace, aeronautics, nuclear power, combustion control, transportation, traffic, safety equipment or medical equipment for life support.
4. Design your application so that the product is used within the ranges guaranteed by Hitachi particularly for maximum rating, operating supply voltage range, heat radiation characteristics, installation conditions and other characteristics. Hitachi bears no responsibility for failure or damage when used beyond the guaranteed ranges. Even within the guaranteed ranges, consider normally foreseeable failure rates or failure modes in semiconductor devices and employ systemic measures such as fail-safes, so that the equipment incorporating Hitachi product does not cause bodily injury, fire or other consequential damage due to operation of the Hitachi product.
5. This product is not designed to be radiation resistant.
6. No one is permitted to reproduce or duplicate, in any form, the whole or part of this document without written approval from Hitachi.
7. Contact Hitachi's sales office for any questions regarding this document or Hitachi semiconductor products.

HITACHI

Hitachi, Ltd.

Semiconductor & Integrated Circuits.
Nippon Bldg., 2-6-2, Ohte-machi, Chiyoda-ku, Tokyo 100-0004, Japan
Tel: Tokyo (03) 3270-2111 Fax: (03) 3270-5109

URL North America : <http://semiconductor.hitachi.com/>
 Europe : <http://www.hitachi-eu.com/hel/ecg>
 Asia (Singapore) : <http://www.has.hitachi.com.sg/grp3/sicd/index.htm>
 Asia (Taiwan) : http://www.hitachi.com.tw/E/Product/SICD_Frame.htm
 Asia (HongKong) : <http://www.hitachi.com.hk/eng/bo/grp3/index.htm>
 Japan : <http://www.hitachi.co.jp/Sicd/indx.htm>

For further information write to:

Hitachi Semiconductor
(America) Inc.
179 East Tasman Drive,
San Jose, CA 95134
Tel: <1> (408) 433-1990
Fax: <1> (408) 433-0223

Hitachi Europe GmbH
Electronic components Group
Dornacher Straße 3
D-85622 Feldkirchen, Munich
Germany
Tel: <49> (89) 9 9180-0
Fax: <49> (89) 9 29 30 00

Hitachi Europe Ltd.
Electronic Components Group.
Whitebrook Park
Lower Cookham Road
Maidenhead
Berkshire SL6 8YA, United Kingdom
Tel: <44> (1628) 585000
Fax: <44> (1628) 778322

Hitachi Asia Pte. Ltd.
16 Collyer Quay #20-00
Hitachi Tower
Singapore 049318
Tel: 535-2100
Fax: 535-1533

Hitachi Asia Ltd.
Taipei Branch Office
3F, Hung Kuo Building, No.167,
Tun-Hwa North Road, Taipei (105)
Tel: <886> (2) 2718-3666
Fax: <886> (2) 2718-8180

Hitachi Asia (Hong Kong) Ltd.
Group III (Electronic Components)
7/F., North Tower, World Finance Centre,
Harbour City, Canton Road, Tsim Sha Tsui,
Kowloon, Hong Kong
Tel: <852> (2) 735 9218
Fax: <852> (2) 730 0281
Telex: 40815 HITEC HX

Copyright ' Hitachi, Ltd., 1999. All rights reserved. Printed in Japan.

HITACHI



LittleDiode supplies new, hard to find or obsolete electronic components and semiconductors all over the world.

With over two million different components listed you are sure to find the part you need.

Feel free to visit us today at our online store:

LittleDiode.com

Looking forward to providing you with the best possible service.