

HD14006B

18-bit Static Shift Register

The HD14006B shift register is comprised of four separate shift register sections sharing a common clock: two sections have four stages and two sections have five stages with an output tap on both the fourth and fifth stages. This makes it possible to obtain a shift register of 4, 5, 8, 9, 10, 12, 13, 14, 16, 17 or 18 bits by appropriate selection of inputs and outputs. This part is particularly useful in serial shift registers and time delay circuits.

FEATURES

- Output Transitions Occur on the Falling Edge of the Clock Pulse
- Quiescent Current = 5nA/pkg typ @5V
- Fully Static Operation
- 8MHz Shift Rate Typical
- Can be Cascaded to Provide Longer Shift Register Lengths
- Supply Voltage Range = 3 to 18V
- Capable of Driving One Lowpower Schottky TTL Load Over the Rated Temperature Range
- Pin-for-Pin Replacement for CD4006B and MC14006B

PIN ARRANGEMENT

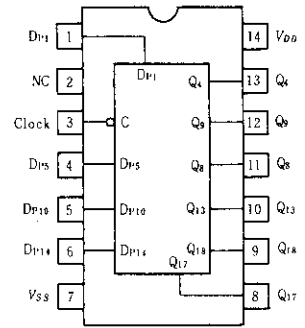

(Top View)

TRUTH TABLE

D_n	C	Q_{n+1}
0		0
1		1
X		Q_n

X : Don't Care

BLOCK DIAGRAM

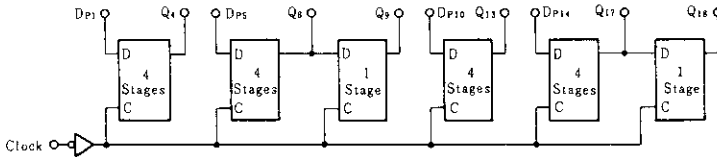

LOGIC DIAGRAM

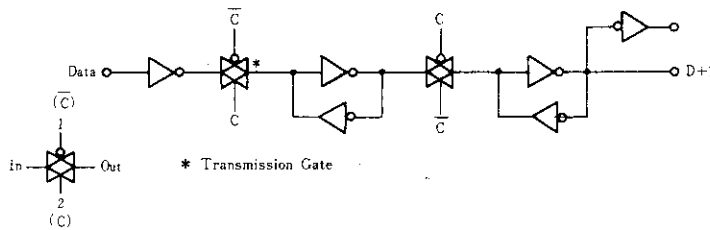

DC CHARACTERISTIC TEST CIRCUIT

● I_{OH}

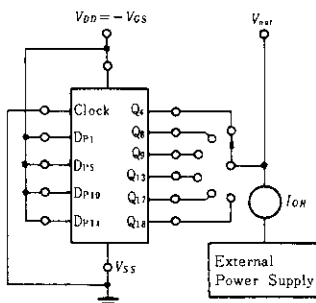

● I_{OL}

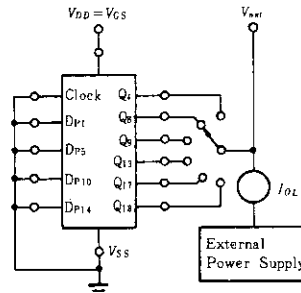

ELECTRICAL CHARACTERISTICS

Characteristic	Symbol	V _{DD} (V)	Test Conditions	-40°C		25°C			85°C		Unit
				min	max	min	typ	max	min	max	
Output Voltage	V _{OL}	5.0	V _{in} =V _{DD} or 0	—	0.05	—	0	0.05	—	0.05	V
		10		—	0.05	—	0	0.05	—	0.05	
		15		—	0.05	—	0	0.05	—	0.05	
	V _{OH}	5.0	V _{in} =0 or V _{DD}	4.95	—	4.95	5.0	—	4.95	—	V
		10		9.95	—	9.95	10	—	9.95	—	
		15		14.95	—	14.95	15	—	14.95	—	
Input Voltage	V _{IL}	5.0	V _{out} =4.5 or 0.5V	—	1.5	—	2.25	1.5	—	1.5	V
		10	V _{out} =9.0 or 1.0V	—	3.0	—	4.50	3.0	—	3.0	
		15	V _{out} =13.5 or 1.5V	—	4.0	—	6.75	4.0	—	4.0	
	V _{IH}	5.0	V _{out} =0.5 or 4.5V	3.5	—	3.5	2.75	—	3.5	—	V
		10	V _{out} =1.0 or 9.0V	7.0	—	7.0	5.50	—	7.0	—	
		15	V _{out} =1.5 or 13.5V	11.0	—	11.0	8.25	—	11.0	—	
Output Drive Current	I _{OH}	5.0	V _{OH} =2.5V	-1.0	—	-0.8	-1.7	—	-0.6	—	mA
		5.0	V _{OH} =4.6V	-0.2	—	-0.16	-0.36	—	-0.12	—	
		10	V _{OH} =9.5V	-0.5	—	-0.4	-0.9	—	-0.3	—	
	I _{OL}	15	V _{OH} =13.5V	-1.4	—	-1.2	-3.5	—	-1.0	—	
		5.0	V _{OL} =0.4V	0.52	—	0.44	0.88	—	0.36	—	mA
		10	V _{OL} =0.5V	1.3	—	1.1	2.25	—	0.9	—	
15	V _{OL} =1.5V	3.6	—	3.0	8.8	—	2.4	—			
Input Current	I _{in}	15		—	±0.3	—	±0.0001	±0.3	—	±1.0	μA
Input Capacitance	C _{in}	—	V _{in} =0	—	—	—	5.0	7.5	—	—	pF
Quiescent Current	I _{DD}	5.0	Zero Signal, per Package	—	20	—	0.005	20	—	150	μA
		10		—	40	—	0.010	40	—	300	
		15		—	80	—	0.015	80	—	600	
Total Supply Current*	I _T	5.0	Dynamic + I _{DD} ,	—	—	—	1.3	—	—	—	μA
		10	Per Gate,	—	—	—	2.6	—	—	—	
		15	C _L =50pF, f=1kHz	—	—	—	3.9	—	—	—	

* To calculate total supply current at frequency other than 1kHz.
 @V_{DD}=5.0V I_T=(1.3μA/kHz)f+I_{DD}, @V_{DD}=10V I_T=(2.6μA/kHz)f+I_{DD}, @V_{DD}=15V I_T=(3.9μA/kHz)f+I_{DD}

POWER DISSIPATION TEST CIRCUIT AND WAVEFORM

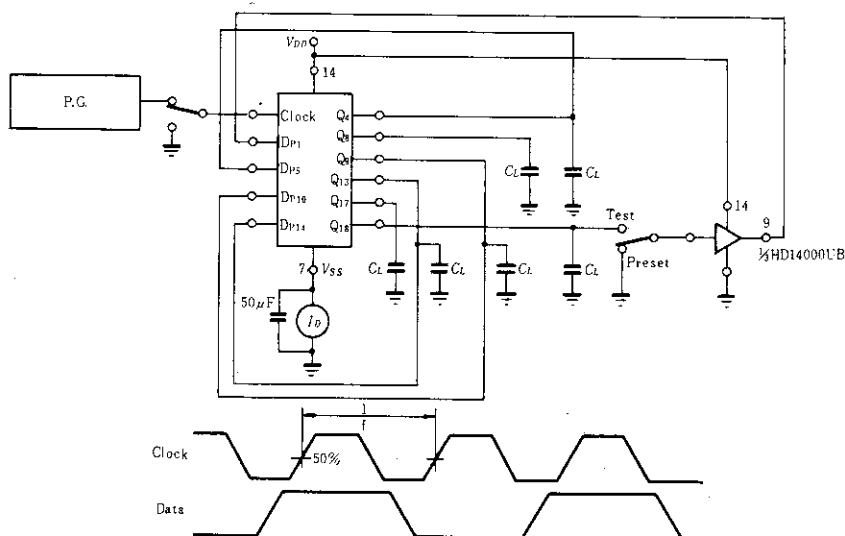

■ SWITCHING CHARACTERISTICS ($C_L=50\text{pF}$, $T_a=25^\circ\text{C}$)

Characteristic	Symbol	V_{DD} (V)	min	typ	max	Unit
Output Rise Time	t_r	5.0	—	180	400	ns
		10	—	90	200	
		15	—	65	160	
Output Fall Time	t_f	5.0	—	100	200	ns
		10	—	50	100	
		15	—	37	80	
Propagation Delay Time	t_{PLH} , t_{PHL}	5.0	—	305	600	ns
		10	—	110	275	
		15	—	80	200	
Clock Pulse Width	PW_C	5.0	250	100	—	ns
		10	125	60	—	
		15	95	40	—	
Clock Pulse Frequency	PRF	5.0	—	5.0	2.0	MHz
		10	—	8.3	4.0	
		15	—	12	6.0	
Clock Pulse Rise and Fall Time	t_r, t_f	5.0	—	—	15	μs
		10	—	—	15	
		15	—	—	15	
Setup Time	t_{setup}	5.0	0	-50	—	ns
		10	0	-15	—	
		15	0	-8.0	—	
Hold Time	t_{hold}	5.0	220	75	—	ns
		10	110	25	—	
		15	90	20	—	

■ SWITCHING TIME TEST CIRCUIT

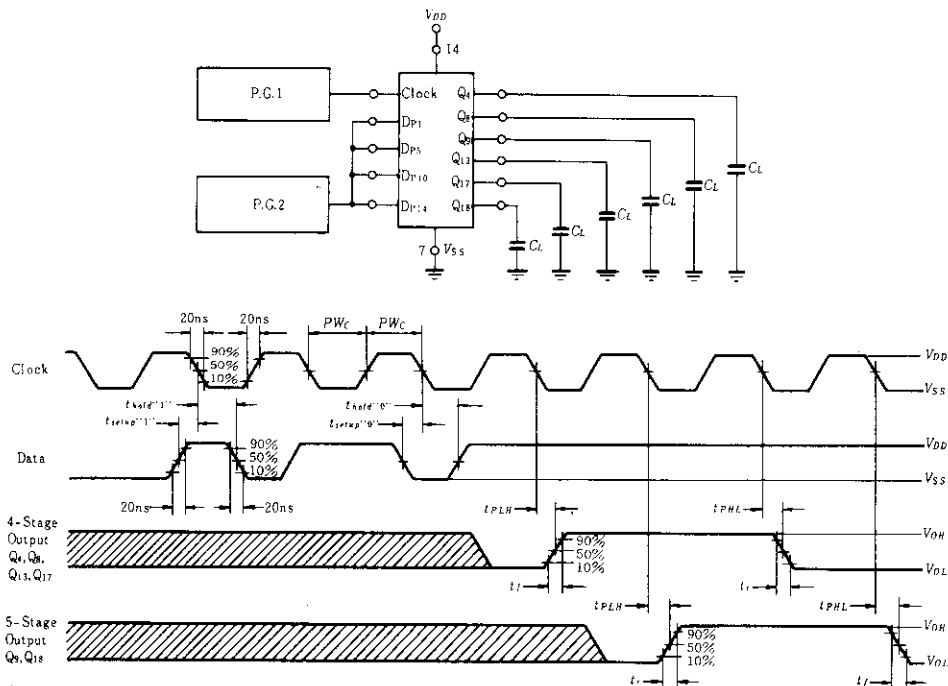

▨ Output state can change since data previously clocked in might be in either state.

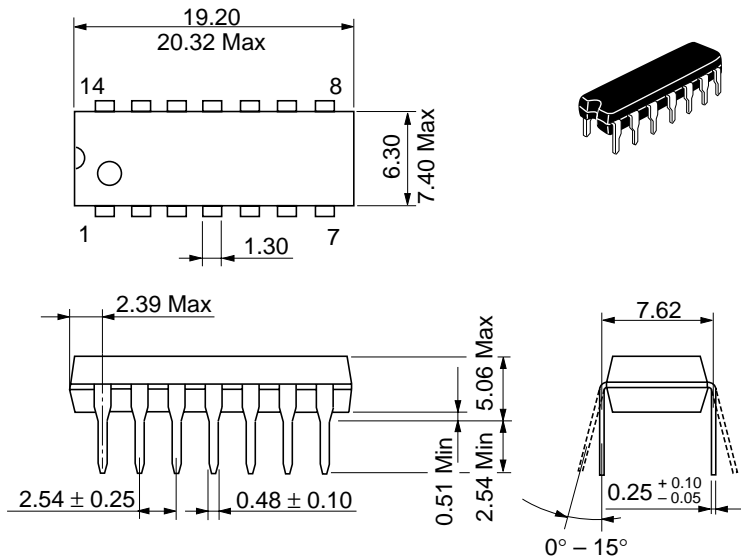

Hitachi Code	DP-14
JEDEC	Conforms
EIAJ	Conforms
Weight (reference value)	0.97 g

Cautions

1. Hitachi neither warrants nor grants licenses of any rights of Hitachi's or any third party's patent, copyright, trademark, or other intellectual property rights for information contained in this document. Hitachi bears no responsibility for problems that may arise with third party's rights, including intellectual property rights, in connection with use of the information contained in this document.
2. Products and product specifications may be subject to change without notice. Confirm that you have received the latest product standards or specifications before final design, purchase or use.
3. Hitachi makes every attempt to ensure that its products are of high quality and reliability. However, contact Hitachi's sales office before using the product in an application that demands especially high quality and reliability or where its failure or malfunction may directly threaten human life or cause risk of bodily injury, such as aerospace, aeronautics, nuclear power, combustion control, transportation, traffic, safety equipment or medical equipment for life support.
4. Design your application so that the product is used within the ranges guaranteed by Hitachi particularly for maximum rating, operating supply voltage range, heat radiation characteristics, installation conditions and other characteristics. Hitachi bears no responsibility for failure or damage when used beyond the guaranteed ranges. Even within the guaranteed ranges, consider normally foreseeable failure rates or failure modes in semiconductor devices and employ systemic measures such as fail-safes, so that the equipment incorporating Hitachi product does not cause bodily injury, fire or other consequential damage due to operation of the Hitachi product.
5. This product is not designed to be radiation resistant.
6. No one is permitted to reproduce or duplicate, in any form, the whole or part of this document without written approval from Hitachi.
7. Contact Hitachi's sales office for any questions regarding this document or Hitachi semiconductor products.

HITACHI

Hitachi, Ltd.

Semiconductor & Integrated Circuits.
Nippon Bldg., 2-6-2, Ohte-machi, Chiyoda-ku, Tokyo 100-0004, Japan
Tel: Tokyo (03) 3270-2111 Fax: (03) 3270-5109

URL North America : <http://semiconductor.hitachi.com/>
 Europe : <http://www.hitachi-eu.com/hel/ecg>
 Asia (Singapore) : <http://www.has.hitachi.com.sg/grp3/sicd/index.htm>
 Asia (Taiwan) : http://www.hitachi.com.tw/E/Product/SICD_Frame.htm
 Asia (HongKong) : <http://www.hitachi.com.hk/eng/bo/grp3/index.htm>
 Japan : <http://www.hitachi.co.jp/Sicd/indx.htm>

For further information write to:

Hitachi Semiconductor
(America) Inc.
179 East Tasman Drive,
San Jose, CA 95134
Tel: <1> (408) 433-1990
Fax: <1> (408) 433-0223

Hitachi Europe GmbH
Electronic components Group
Dornacher Straße 3
D-85622 Feldkirchen, Munich
Germany
Tel: <49> (89) 9 9180-0
Fax: <49> (89) 9 29 30 00

Hitachi Europe Ltd.
Electronic Components Group.
Whitebrook Park
Lower Cookham Road
Maidenhead
Berkshire SL6 8YA, United Kingdom
Tel: <44> (1628) 585000
Fax: <44> (1628) 778322

Hitachi Asia Pte. Ltd.
16 Collyer Quay #20-00
Hitachi Tower
Singapore 049318
Tel: 535-2100
Fax: 535-1533

Hitachi Asia Ltd.
Taipei Branch Office
3F, Hung Kuo Building, No.167,
Tun-Hwa North Road, Taipei (105)
Tel: <886> (2) 2718-3666
Fax: <886> (2) 2718-8180

Hitachi Asia (Hong Kong) Ltd.
Group III (Electronic Components)
7/F., North Tower, World Finance Centre,
Harbour City, Canton Road, Tsim Sha Tsui,
Kowloon, Hong Kong
Tel: <852> (2) 735 9218
Fax: <852> (2) 730 0281
Telex: 40815 HITEC HX

Copyright ' Hitachi, Ltd., 1999. All rights reserved. Printed in Japan.

HITACHI



LittleDiode supplies new, hard to find or obsolete electronic components and semiconductors all over the world.

With over two million different components listed you are sure to find the part you need.

Feel free to visit us today at our online store:

LittleDiode.com

Looking forward to providing you with the best possible service.