

## Seven Segment Display 13 mm (0.59")

HD 1131  
HD 1133

### Features

- Excellent readability by ambient light
- Excellent character appearance
- Evenly lighted segments
- Wide viewing angle  $2\varphi = 50^\circ$
- Mitred corners on segments
- Grey package provides optimum contrast
- IC-compatible
- Right hand decimal

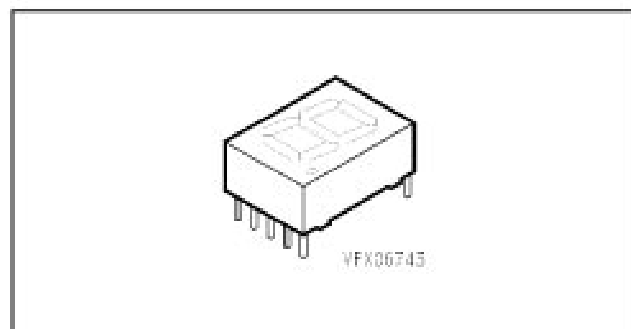

Type	Polarity	Color of emission	Luminous intensity/ Segment $I_F = 10 \text{ mA}$ $I_V (\mu\text{cd})$	Ordering code
HD 1131 R	common anode	red	550 (typ.)	Q68000-A7821
HD 1131 O		super-red	4000 (typ.)	Q68000-A7822
HD 1131 G		green	4500 (typ.)	Q68000-A7820
HD 1133 R	common cathode	red	550 (typ.)	Q68000-A7873
HD 1133 O		super-red	4000 (typ.)	Q68000-A7872
HD 1133 G		green	4500 (typ.)	Q68000-A7871

## Maximum Ratings ( $T_A = 25\text{ °C}$ )

Description	Symbol	Value	Unit
Operating temperature range	$T_{op}$	0 ... + 85	°C
Storage temperature range	$T_{stg}$	- 40 ... + 85	°C
Lead soldering temperature, 2 mm from base	$T_S$	260	°C for 3 s
Peak forward current per segment or DP <sup>1)</sup> $t_P \leq 10\ \mu\text{s}$ HD 113* R HD 113* O, -G	$I_{FM}$ $I_{FM}$	500 150	mA mA
DC forward current per segment or DP <sup>2)</sup> HD 113* R HD 113* O, -G	$I_F$ $I_F$	35 25	mA mA
Reverse voltage per segment or DP	$V_R$	6	V
Total power dissipation $T_A \leq 45\text{ °C}$	$P_{tot}$	600	mW

1) Do not exceed maximum average current per segment (see graph of the permissible pulse handling capability)

2) Derate maximum average current above  $T_A = 75\text{ °C}$  at  $0.5\text{ mA/°C}$  per segment

Characteristics ( $T_A = 25\text{ °C}$ )

Parameter	Symbol	Values			Unit
		min	typ.	ma	
Luminous intensity per segment, $I_F = 10\text{ mA}$					
HD 1131 R, HD 1133 R	$I_V$	180	550	-	$\mu\text{cd}$
HD 1131 O, HD 1133 O	$I_V$	110	400	-	$\mu\text{cd}$
HD 1131 G, HD 1133 G	$I_V$	0	0	-	$\mu\text{cd}$
Peak wavelength, $I_F = 10\text{ mA}$					
HD 1131 R, HD 1133 R	$\lambda_{\text{peak}}$	-	660	-	nm
HD 1131 O, HD 1133 O	$\lambda_{\text{peak}}$	-	630	-	nm
HD 1131 G, HD 1133 G	$\lambda_{\text{peak}}$	-	565	-	nm
Dominant wavelength (Digit average)					
HD 1131 R, HD 1133 R	$\lambda_{\text{dom}}$	-	645	-	nm
HD 1131 O, HD 1133 O	$\lambda_{\text{dom}}$	612	-	625	nm
HD 1131 G, HD 1133 G	$\lambda_{\text{dom}}$	562	-	575	nm
Forward voltage per segment*, $I_F = 20\text{ mA}$					
HD 1131 R, HD 1133 R	$V_F$	-	1.6	2.0	V
HD 1131 O, HD 1133 O	$V_F$	-	2.0	3.0	V
HD 1131 G, HD 1133 G	$V_F$	-	2.4	3.0	V
Break down voltage per segment* $I_R = 10\text{ }\mu\text{A}$	$V_{BR}$	6	15	-	V
Max. thermal resistance	$R_{thJA}$	-	-	100	$^{\circ}\text{C/W/Seg}$

\*) AQL = 0.4%

**Relative spectral emission  $I_{rel} = f(\lambda)$**

$V(\lambda)$  = Standard eye response curve

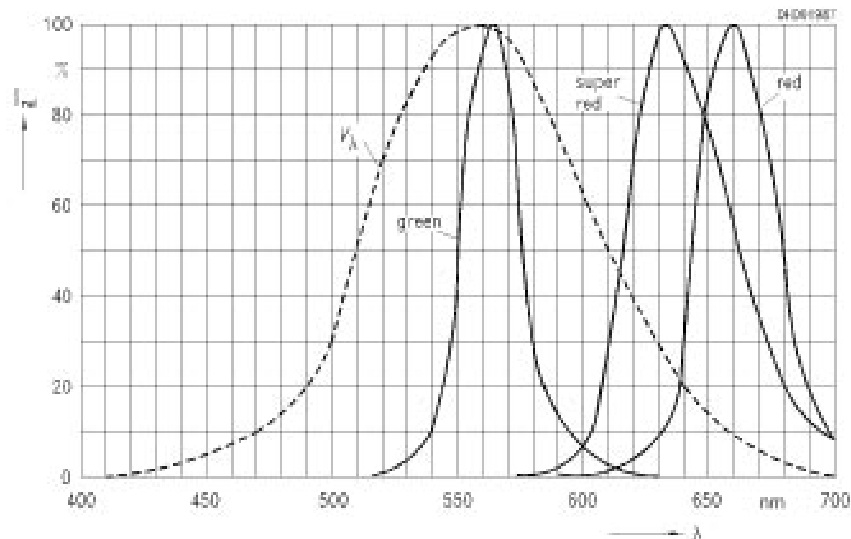

**Forward current  $I_F = f(V_F)$**

$T_A = 25^\circ\text{C}$

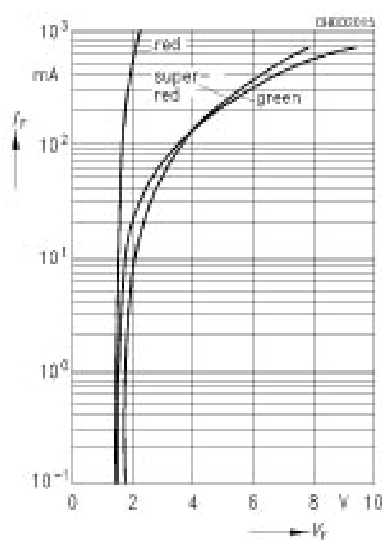

**Rel. luminous intensity  $I_v/I_v(25^\circ\text{C}) = f(T_A)$**

$I_F = 10\text{ mA}$

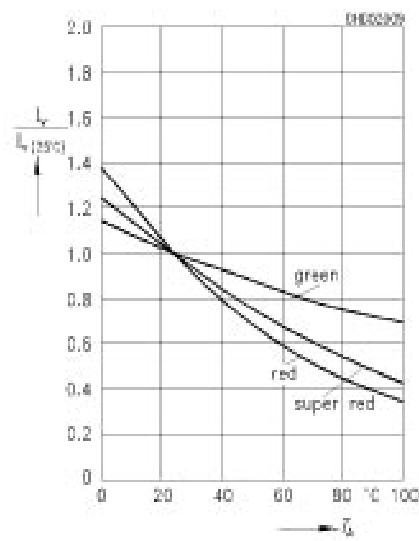

### Permissible pulse handling capability

$$I_F = f(t_p), T_A \leq 45^\circ\text{C}$$

red

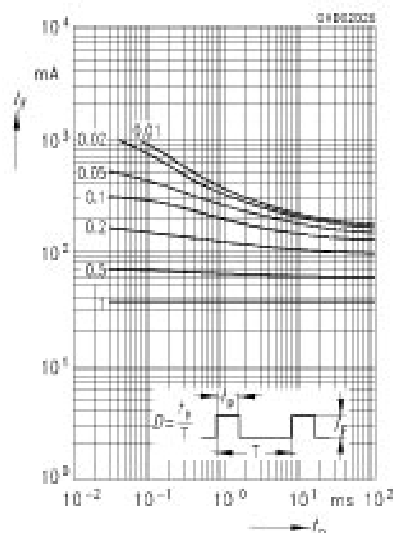

### Permissible pulse handling capability

$$I_F = f(t_p), T_A \leq 45^\circ\text{C}$$

super-red, green

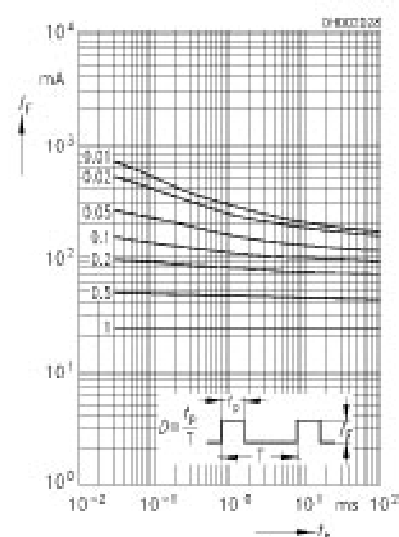

### Max. permissible forward current

$$I_F = f(T_A)$$

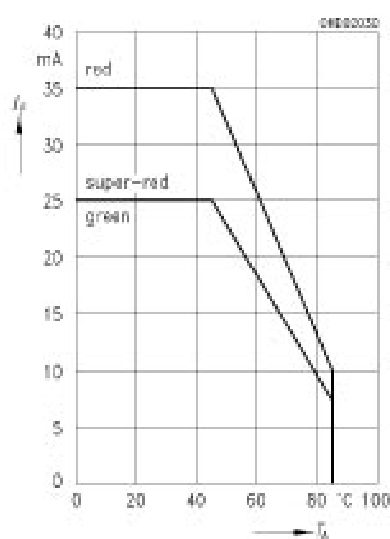

### Rel. luminous intensity $I_v/I_{v(10\text{mA})} = f(I_F)$

$$T_A = 25^\circ\text{C}$$

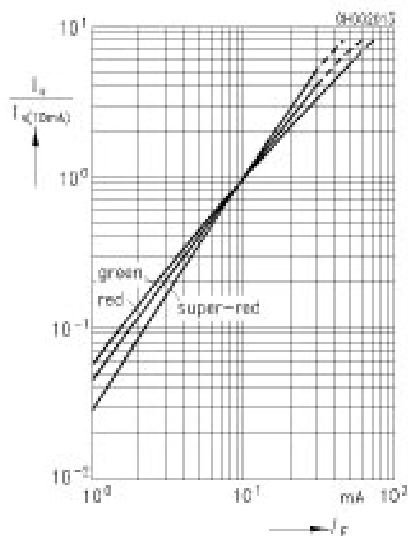

## Total power dissipation $P_{tot} = f(T_A)$

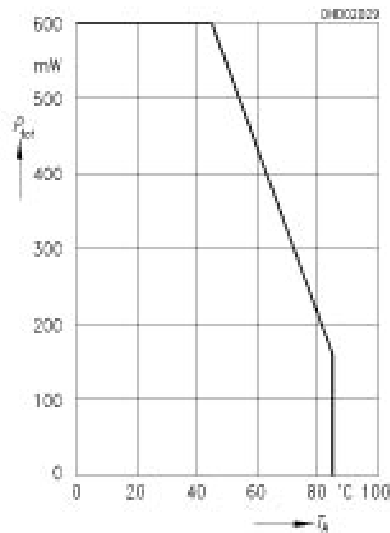

## Package Outlines

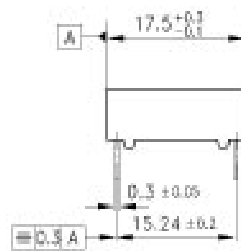
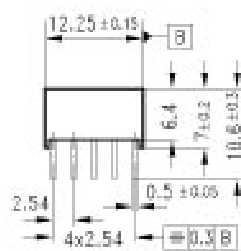

HD 1131  
HDN1131

a-1			10-g
d-2			9-l
A-3			8-A
c-4			7-a
dp-5			6-b

A=common anode

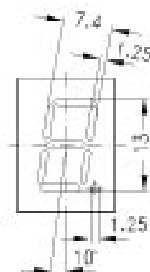

HD 1133  
HDN1133

a-1			10-g
d-2			9-l
C-3			8-C
c-4			7-a
dp-5			6-b

C=common cathode



GP028743



LittleDiode supplies new, hard to find or obsolete electronic components and semiconductors all over the world.

With over two million different components listed you are sure to find the part you need.

Feel free to visit us today at our online store:

[LittleDiode.com](http://LittleDiode.com)

Looking forward to providing you with the best possible service.