

FEATURES

12-Bit Resolution
1MHz Word Rate
T/H and Timing Circuits Included
Single Hybrid Package

APPLICATIONS

Radar Systems
Medical Instrumentation
Electro-Optics Systems
Test Systems
Digital Oscilloscopes

HAS-1201 FUNCTIONAL BLOCK DIAGRAM

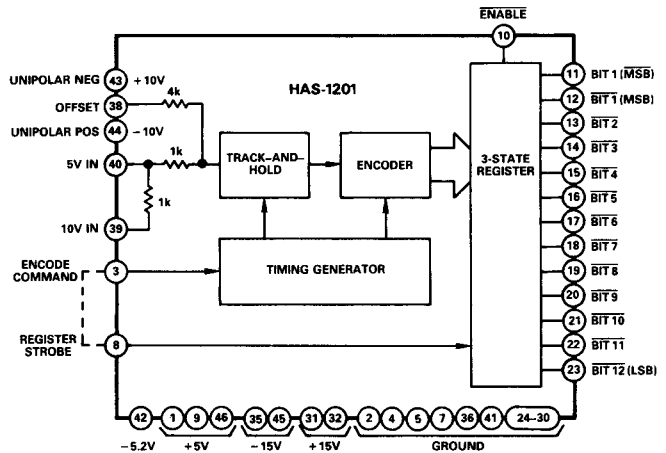

GENERAL DESCRIPTION

The HAS-1201 A/D Converter combines high resolution and speed in a single hybrid package. This is a *complete* 12-bit, 1MHz unit which includes a track-and-hold and timing circuits. It's a total solution for the system designer who needs to perform the entire analog-to-digital conversion function in the smallest possible space.

This remarkable converter is a full answer to the question of digitizing analog signals into high-resolution data outputs and doing it in the most cost-effective way. The HAS-1201 is the ideal choice for the designer who needs state-of-the-art performance in high-resolution, high-speed A/D conversion.

Full-scale analog inputs are 5 or 10 volts; and the unit can operate with either bipolar or unipolar ranges. Analog input impedance is 1,000 ohms or 2,000 ohms and the three-state digital outputs are TTL compatible. The user needs to supply only an encode command and external power supplies for operation.

All models of the HAS-1201 A/D Converter are housed in 46-pin metal hybrid packages. The HAS-1201KM operates over a temperature range of 0 to +70°C. The HAS-1201SM is rated over an operating temperature range of -25°C to +85°C, but will operate with derated performance over a range of -55°C to +100°C. For units operating from -25°C to +85°C and military screening, order HAS-1201SMB; contact the factory for details about derated performance and military screening.

SPECIFICATIONS (typical @ +25°C with nominal power supplies unless otherwise noted)

Parameter	Units	HAS-1201KM	HAS-1201SM/SMB
RESOLUTION (FS = Full Scale)	Bits	12	*
	% FS	0.025	*
ACCURACY			
Gain	% FS	±3	*
Gain vs. Temperature	ppm/°C	80	*
Linearity @ dc	% FS ± 1/2LSB	0.0125	*
Diff. Nonlinearity vs. Temp.	ppm/°C	10	15
Monotonicity		Guaranteed	*
DYNAMIC CHARACTERISTICS			
In-Band Harmonics¹			
(dc to 100kHz)	dB below FS (min)	80 (75)	*
(100kHz to 500kHz)	dB below FS	75	*
Conversion Rate	MHz, max	1.05	1.00
Conversion Time ²	ns, max	950	*
Over Temperature	ns, max	950	1000
Aperture Uncertainty (Jitter)	ps, rms	30	*
Aperture Time (Delay)	ns	25	*
Signal-to Noise Ratio (SNR) ³	dB (min)	68 (65)	*
Transient Response ⁴	ns (max)	600 (1000)	*
Overvoltage Recovery ⁵	ns	1000	*
Input Bandwidth			
Small Signal, -3dB ⁶	MHz	2	*
Large Signal, -3dB ⁷	MHz	2	*
Two-Tone Linearity (@ input frequencies) (75kHz; 105kHz)	dB below FS	80	*
ANALOG INPUT			
Voltage Ranges			
V, p-p FS		5.0/10.0	*
V, max		±15	*
Impedance (5V/10V Input)			
Bipolar Offset ⁸	Ω (max)	1000/2000 (±1%)	*
Initial (5V Input) vs. Temperature	mV (max)	±2 (±10)	*
	FS ppm/°C (max)	50 (200)	*
DIGITAL INPUTS			
Logic Levels, TTL-Compatible			
V		"0" = 0 to +0.4	*
V		"1" = +2.4 to +5	*
Impedance			
LS TTL Loads		3	*
Rise and Fall Times	ns, max	10	*
Frequency	MHz, max	1.05	1.00
Encode Command Width⁹			
Min	ns	50	*
Max	ns	Encode Period - 350ns	*
Register Strobe Width			
Min	ns	50	*
Max	ns	Encode Period - 350ns	*
Enable Width			
Min	ns	100	*
DIGITAL OUTPUTS			
Format			
Bit 1,			
Bit 1 - Bit 12		3-State; NRZ	*
Logic Levels, TTL-Compatible¹⁰			
V		"0" = 0 to +0.5	*
		"1" = +2.4 to +5	*
Drive	TTL Loads	1	*
Time Skew	ns, max	10	*
Delay: Register Strobe to Output Data Validity Coding	ns	30	*
		Complementary Binary (CBIN)	*
		Complementary Offset Binary (COB)	*
		Complementary 2's Complement (C2SC)	*
POWER REQUIREMENTS			
+15V ±5%	mA (max)	55 (70)	*
-15V ±5%	mA (max)	65 (80)	*
+5V ±5%	mA (max)	195 (235)	*
-5.2V ±5%	mA (max)	35 (40)	*
Power Consumption	W (max)	3.0 (3.6)	*
TEMPERATURE RANGE¹¹			
Operating	°C	0 to +70	-25 to +85
Storage	°C	-55 to +150	*
THERMAL RESISTANCE¹²			
Junction to Air, θ _{ja} (Free Air)	°C/W	12	*
Junction to Case, θ _{jc}	°C/W	2.5	*
PACKAGE OPTION¹³			
M-46		HAS-1201KM	HAS-1201SM HAS1201SMB

HAS-1201 PIN DESIGNATION

PIN	FUNCTION	PIN	FUNCTION
46	+5V	1	+5V
45	-15V	2	GROUND
44	UNIPOLAR POSITIVE	3	ENCODE COMMAND
43	UNIPOLAR NEGATIVE	4	GROUND
42	-5.2V	5	GROUND
41	GROUND	6	DO NOT CONNECT*
40	5V RANGE IN	7	GROUND
39	10V RANGE IN	8	REGISTER STROBE
38	OFFSET	9	+5V
37	DO NOT CONNECT*	10	ENABLE
36	GROUND	11	BIT 1 (MSB)
35	-15V	12	BIT 1 (MSB)
34	NO CONNECTION	13	BIT 2
33	NO CONNECTION	14	BIT 3
32	+15V	15	BIT 4
31	+15V	16	BIT 5
30	GROUND	17	BIT 6
29	GROUND	18	BIT 7
28	GROUND	19	BIT 8
27	GROUND	20	BIT 9
26	GROUND	21	BIT 10
25	GROUND	22	BIT 11
24	GROUND	23	BIT 12 (LSB)

NOTE:
PINS 2, 4, 5, 7, 24-30, 36 and 41 NEED TO BE CONNECTED TO THE SAME COMMON GROUND AS CLOSE TO CASE AS POSSIBLE. POWER SUPPLY VOLTAGES NEED TO BE CONNECTED TO ALL DESIGNATED PINS.
*FOR FACTORY USE ONLY.

NOTES

- In-Band Harmonics expressed in terms of spurious in-band signals generated at 1MHz encode rate at analog inputs shown in ().
 - Measured from leading edge of Encode Command to time associated data are valid.
 - RMS signal to rms noise ratio with 100kHz analog input.
 - For full-scale step input, 12-bit accuracy attained in specified time.
 - Recovers to specified performance in specified time after 2 × FS input overvoltage.
 - With analog input 40dB below FS.
 - With FS analog input. (Large-signal bandwidth flat within 0.5dB, dc to 500kHz.)
 - Externally adjustable to zero.
 - Transition from digital "0" to digital "1" initiates encoding.
 - Output data are TTL-compatible when analog input is within specified range. Negative over-voltage inputs cause tri-state output to drift to "high" condition and may create erroneous output (see text).
 - Case Temperature. Models HAS-1201SM/SMB will operate with derated performance over temperature range of -55°C to +100°C; contact factory for details.
 - Maximum junction temperature is +150°C.
 - See Section 14 for package outline information.
- Specifications subject to change without notice.

For applications assistance, phone Computer Labs Division at (919) 668-9511

THEORY OF OPERATION

Refer to the block diagram of the HAS-1201 A/D Converter.

This is a functional illustration of the HAS-1201 A/D Converter. Internally, the converter uses digitally corrected subranging (DCS) pioneered by Analog Devices to generate 14 bits of digital data. The two extra bits are used for digital correction to assure that the 12 bits of parallel output data are an accurate representation of the analog input signal present at the time of the encode command.

The analog signal to be digitized is applied to an internal track-and-hold (T/H), whose change between the “track” and “hold” modes is determined by the HAS-1201 internal timing circuits. Applying an encode command (at Pin 3) triggers these circuits and causes the required timing signals to be generated.

Timing intervals for the various signals involved in the operation of the HAS-1201 A/D Converter are shown in Figure 1.

Understanding the operation of the HAS-1201 is easiest when the timing of events is related to the leading edge of the Encode Command. Minimum width of that signal is 50ns; maximum width is the period of the encode rate less 350ns. A square wave is always an acceptable encode signal for the HAS-1201 converter.

For purposes of illustration, spacing between Encode Commands #1 and #2 in Figure 1 is approximately equal to a word rate of 500kHz.

When the encode command is applied, the unit switches to the hold mode for approximately 670 nanoseconds; the length of the track mode is a function of word rate. When operated at its maximum frequency, the HAS-1201 will remain in “track” 280

nanoseconds, the interval required for internal processing of data.

During the first 50 nanoseconds of each hold period, valid data resulting from the previous encode command continue to be applied to the output register. But then, internal switching within the HAS-1201 causes changes to occur until the conversion cycle initiated by the most recent encode command is completed.

Referenced to the leading edge of the encode command, minimum spacing on the Register Strobe is 950ns; maximum spacing is shown with the Register Strobe in dotted lines.

Output data at Pins 11-23 remain valid until updated by a Register Strobe. As noted, this validity interval is based on having the $\overline{\text{ENABLE}}$ connected to either digital “0” or ground.

In Figure 1, the timing of the signals labeled $\overline{\text{ENABLE}}$ and OUTPUT DATA are not referenced to the ENCODE COMMAND; their timing is related only to each other.

If the $\overline{\text{ENABLE}}$ pulse is used to strobe output data into external circuits, the user must assure its arrival corresponds to the availability of valid data. When the $\overline{\text{ENABLE}}$ is at digital “1”, output data present a high impedance to external circuits. Changing $\overline{\text{ENABLE}}$ to a digital “0” causes the three-state logic outputs to become low impedances and makes them available for strobing.

In the block diagram, the external connection of the encode command (Pin 3) to the register strobe (Pin 8) is the connection which might be used if the HAS-1201 were operating at a continuous maximum encode rate of 1.05MHz. Under these circumstances, the output data resulting from Encode Command #1 will be strobed out of the converter with the leading edge of Encode Command #2.

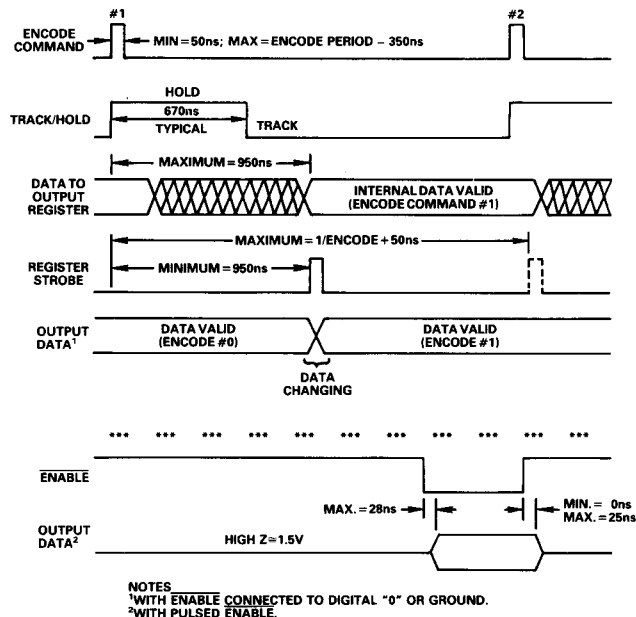

Figure 1. HAS-1201 Timing Diagram

OPERATING HAS-1201 AT WORD RATES LESS THAN MAXIMUM

If encode commands are applied asynchronously, direct connection of these pins results in variations in the times when output data are available, because of pipeline delay through the converter and the differences in intervals between encode commands.

With Pins 3 and 8 connected, the leading edge of each encode command is the signal which strobes output data generated by the preceding encode command. There is no separate, designated output signal indicating data are valid.

As an example, assume the HAS-1201 encode rate varies around 500kHz, but with relatively large differences in the times between encode commands. Under these conditions, the availability of output data will vary; it is often preferable to have outputs available a specified interval after each encode command. A method to achieve this is shown in Figure 2.

The insertion of a delay circuit between the encode command input and the strobe input of the HAS-1201 makes it possible to use each digital output word at a precise time after its associated encode command, even when operating the converter asynchronously.

The delay circuit can take any of several forms. The user may opt to use a fixed delay line with a delay of 950ns or more; in other cases, shift registers could be used. Another possibility is a variable delay, such as multivibrators, adjusted to the optimum delay for each application.

In this latter approach, the period of the multivibrators can be set to any desired time between a minimum of 950ns (the period of 1.05MHz) and a maximum determined by the period of the highest word rate to be used.

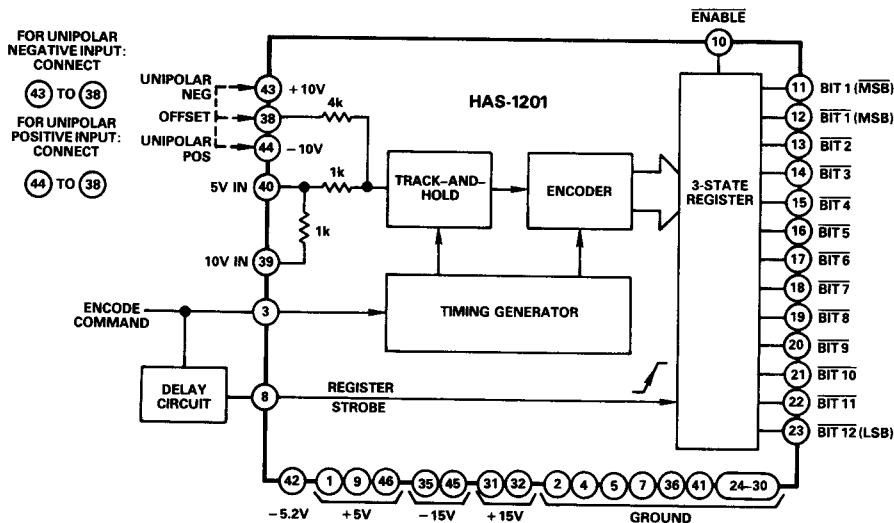

Figure 2. HAS-1201 Connection Diagram

CONNECTING HAS-1201 A/D CONVERTER

At the analog input, the user connects offset (Pin 38) externally to either Pin 43 or Pin 44 to obtain, respectively, unipolar negative or unipolar positive input ranging. The analog signal to be digitized is applied to Pin 39, the 10V input; or to Pin 40, the 5V input, depending upon the application. Examples are shown in Figures 3A-3G.

In Figure 3G, the recommended operational amplifier is an AD741. For 5V Unipolar Negative inputs using this circuit, connect Pin 43 to the positive input of the op amp and leave Pin 44 open.

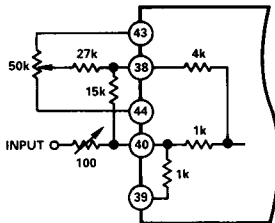

Figure 3A

5V FS Bipolar input
Gain adjustment $\pm 5\%$ FS
Offset adjustment $\pm 5\%$ FS
(Adjust offset first)

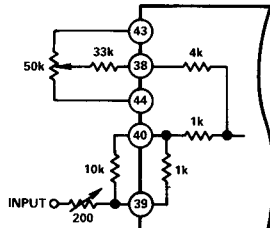

Figure 3B

10V FS Bipolar input
Gain adjustment $\pm 5\%$ FS
Offset adjustment $\pm 5\%$ FS
(Adjust offset first)

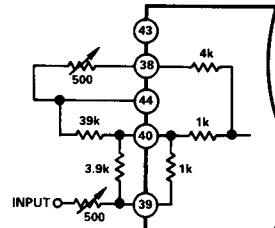

Figure 3C

10V FS Unipolar Positive input
Gain adjustment $\pm 10\%$ FS
Offset adjustment $\pm 5\%$
(Adjust gain first)

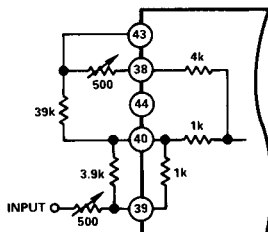

Figure 3D

10V FS Unipolar Negative input
Gain adjustment $\pm 10\%$ FS
Offset adjustment $\pm 5\%$
(Adjust gain first)

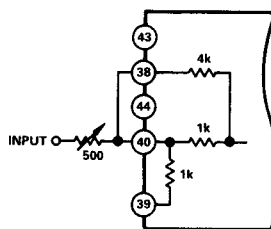

Figure 3E

5V FS Bipolar input
Gain adjustment $\pm 20\%$ FS
No Offset adjustment

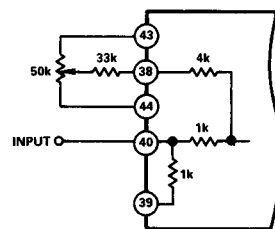

Figure 3F

5V FS Bipolar input
No Gain adjustment
Offset adjustment $\pm 5\%$ FS

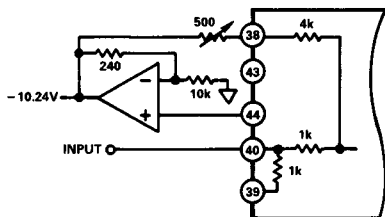

Figure 3G

5V Unipolar Positive input
Offset adjustment $\pm 5\%$
No Gain adjustment
(see text)

Various input ranges with fixed gain and offset are shown in Table I.

INPUT RANGE	CONNECT PINS	INPUT PIN
10V Bipolar	None	39
10V Uni. Pos.	38 to 44	39
10V Uni. Neg.	38 to 43	39
5V Bipolar	None	40
5V Uni. Pos.	38 to 44	40
5V Uni. Neg.	38 to 43	40
4V Bipolar (800 ohms impedance)	38 to 40	40

Table I.

Regardless of the input connection being used, certain basic rules of layout should be observed for any high-speed circuit; this is particularly important for high-resolution devices such as the HAS-1201.

Bypass capacitors are used internally, but all power supplies should be bypassed externally, with $0.01\mu\text{F}$ - $0.1\mu\text{F}$ ceramic capacitors. Electrolytic capacitors of 10-22 microfarads should also be used on each supply; all capacitors should be connected as closely as possible to the supply pins.

A massive ground plane, careful component layout, and physically separating analog and digital signals are among other requirements for assuring the high-speed, high-resolution characteristics of the HAS-1201 A/D Converter.

Supply voltages must be applied to all pins for which they are designated. It is also extremely important to connect all grounds together, and to a solid, low-impedance ground plane.

Cooling air should be passed over the unit when it is being operated; it should be supplied at 300-500 linear feet per minute (LFPM).

The $\overline{\text{ENABLE}}$ signal at Pin 10 can be used for connecting the three-state logic outputs of the HAS-1201 to a bus. A logic "1" at this pin makes the logic outputs "float" at approximately 1.5 volts and causes them to be high impedances during the time other signals are applied to the computer or microprocessor bus.

If the HAS-1201 is not connected to a bus, i.e., it is being used as a system A/D, the $\overline{\text{ENABLE}}$ pin should be connected to logic "0" or ground.

When using the unit as a (free-standing) system A/D, the user should keep in mind the output characteristic noted in the footnotes of the Specifications table on Page 2 of this data sheet.

As a negative-going analog input is increased in value, the digital output of the HAS-1201 follows the changes until all outputs are at logic "1" (unit is operating with Complementary Offset Binary logic), indicating maximum negative analog input. Any further increase in negative input (overranging) will cause the tri-state digital outputs to "float".

The exception to this is the Bit 1 ($\overline{\text{MSB}}$) at Pin 11. Internal pull-down resistors cause it to go to logic "0" and remain.

When they are in an overrange condition, the digital outputs need to look "high". This means the load on the output must pull the open circuits to the "high" state; this requirement normally presents no problem when driving standard TTL or Schottky TTL inputs.

When driving low-power Schottky inputs, the change to "high" will have a slower rise time; it may require up to 100ns. For these, the user should avoid clocking the output data too soon.

CMOS circuits have no provision for pulling up the converter's outputs. In this situation, the recommended procedure is to use 2k pull-up resistors connected to +5 volts.

TESTING HAS-1201 PERFORMANCE

Sophisticated converters of the type represented by the HAS-1201 A/D Converter require sophisticated testing to assure they meet or exceed their specified performance parameters. One of these test methods is a Fast Fourier Transform (FFT) analysis of the converter output.

The results of that testing are shown in Figure 4.

This diagram is an average analysis, based on ten readings. In the test, a 104kHz sine wave is applied as the analog input (f_0), at a level of 1dB below full scale; the HAS-1201 is operated at a word rate of 1.05MHz.

The FFT is based on 512 sample points, with Hanning weighting applied to the digital representations of the analog samples. The resulting spectrum demonstrates the exceptional performance of the converter, particularly in terms of low noise and harmonic distortion.

In Figure 4, the vertical scale is based on a full-scale input referenced as 0dB. In this way, all (frequency) energy cells can be calculated with respect to full-scale rms inputs.

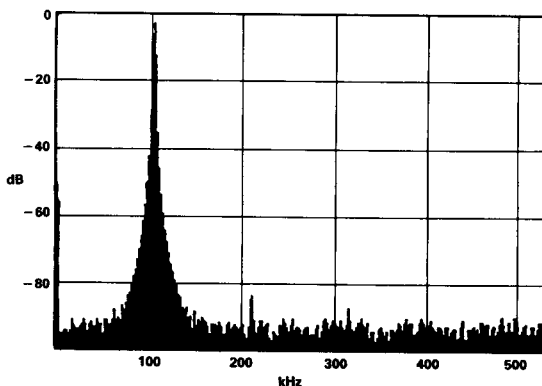

Figure 4. HAS-1201 Output Fast Fourier Transform

Besides the plot shown, the computer testing also supplies numerical data stipulating the precise readings of the second and third harmonics; and the signal-to-noise ratio (SNR). These numbers have been replaced by a horizontal frequency scale for purposes of illustration.

The original numbers indicated the peak amplitude of the second harmonic (208kHz) was at a level of -81dB; the third harmonic (312kHz) was at -85dB. The signal-to-noise ratio was measured at 67.5dB, which corresponds to a noise floor of -68.5dB. All of these numbers, like the plot, are 10-run averages of 512 sample points in each run.

The harmonic distortion numbers include five energy cells on either side of the harmonics of $2 \times f_0$, and $3 \times f_0$. Including these cells helps negate the effects of side lobes caused by the Hanning weighting and non-coherent sampling used for testing.

Hanning, or cosine, weighting is one of several methods of generating FFT data; each method has certain characteristics which make it more or less appropriate for various applications.

ORDERING INFORMATION

Three models of the HAS-1201 A/D Converter are available. For commercial operating temperatures between 0 and +70°C, order model number HAS-1201KM. The HAS-1201SM is rated over an operating temperature range of -25°C to +85°C, but will operate with derated performance over a range of -55°C to +100°C. For units operating from -25°C to +85°C and military screening, order HAS-1201SMB; contact the factory for details about derated performance and military screening.

This datasheet has been downloaded from:

www.DatasheetCatalog.com

Datasheets for electronic components.



LittleDiode supplies new, hard to find or obsolete electronic components and semiconductors all over the world.

With over two million different components listed you are sure to find the part you need.

Feel free to visit us today at our online store:

LittleDiode.com

Looking forward to providing you with the best possible service.