

Dual, Low Noise, Wideband, Precision Operational Amplifier

January 1996

Features

- This Circuit is Processed in Accordance to MIL-STD-883 and is Fully Conformant Under the Provisions of Paragraph 1.2.1.
- Gain Bandwidth Product 100MHz (Min)
- Unity Gain Bandwidth 30MHz (Min)
40MHz (Typ)
- High Slew Rate 25V/μs (Min)
37V/μs (Typ)
- Low Offset Voltage 0.75mV (Max)
0.30mV (Typ)
- High Open Loop Gain 106dB (Min)
128dB (Typ)
- Channel Separation (at 10kHz) 110dB (Typ)
- Low Voltage Noise (at 1kHz) 5.9nV/√Hz (Max)
3.3nV/√Hz (Typ)
- Low Current Noise (at 1kHz) 2.7pA/√Hz (Max)
1.3pA/√Hz (Typ)
- High Output Current ±30mA (Min)
±56mA (Typ)
- Low Supply Current (per Op Amp.) 10mA (Max)
8mA (Typ)

Applications

- Precision Test Systems
- Active Filtering
- Small Signal Video
- Accurate Signal Processing
- RF Signal Conditioning

Description

The HA-5222/883 is a dual, high performance, dielectrically isolated, monolithic op amp, featuring precision DC characteristics while providing excellent AC characteristics. Designed for audio, video, and other demanding applications, noise (3.3nV/√Hz at 1kHz typ), total harmonic distortion (<0.005% typ), and DC errors are kept to a minimum.

The precision performance is shown by low offset voltage (0.3mV typ), low bias currents (40nA typ), low offset currents (15nA typ), and high open loop gain (128dB typ). The combination of these excellent DC characteristics with fast settling time (0.4μs typ) make the HA-5222/883 ideally suited for precision signal conditioning.

The unique design of the HA-5222/883 gives this device outstanding AC characteristics, including high unity gain bandwidth (40MHz typ) and high slew rate (37V/μs typ), not normally associated with precision op amps. Other key specifications include high CMRR (95dB typ) and high PSRR (100dB typ). The combination of these specifications will allow the HA-5222/883 to be used in RF signal conditioning as well as video amplifiers.

Ordering Information

PART NUMBER	TEMPERATURE RANGE	PACKAGE
HA7-5222/883	-55°C to +125°C	8 Lead CerDIP

Pinout

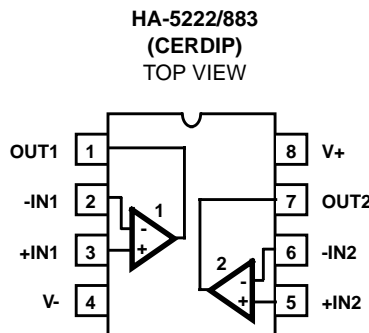

Specifications HA-5222/883

Absolute Maximum Ratings

Voltage Between V+ and V- Terminals 36V
 Differential Input Voltage 5V
 Voltage at Either Input Terminal V+ to V-
 Peak Output Current (Pulsed at 1ms, 10% Duty Cycle) 100mA
 Continuous Output Current Short Circuit Protected
 Junction Temperature +175°C
 Storage Temperature Range -65°C to +150°C
 ESD Rating <2000V
 Lead Temperature (Soldering 10s) +300°C

Thermal Information (Typical)

Thermal Resistance θ_{JA} θ_{JC}
 CerDIP Package 96°C/W 16°C/W
 Package Power Dissipation Limit at +75°C
 CerDIP Package 1.04W
 Package Power Dissipation Derating Factor Above +75°C
 CerDIP Package 10.4mW/°C

CAUTION: Stresses above those listed in "Absolute Maximum Ratings" may cause permanent damage to the device. This is a stress only rating and operation of the device at these or any other conditions above those indicated in the operational sections of this specification is not implied.

Operating Conditions

Operating Temperature Range -55°C to +125°C $V_{INCM} \leq 1/2 (V+ - V-)$
 Operating Supply Voltage $\pm 5V$ to $\pm 15V$ $R_L \geq 1k\Omega$

TABLE 1. DC ELECTRICAL PERFORMANCE CHARACTERISTICS

Device Tested at: $V_{SUPPLY} = \pm 15V$, $R_{LOAD} = 1k\Omega$, $V_{OUT} = 0V$, Unless Otherwise Specified.

PARAMETERS	SYMBOL	CONDITIONS	GROUP A SUBGROUPS	TEMPERATURE	LIMITS		UNITS
					MIN	MAX	
Input Offset Voltage	V_{IO}	$V_{CM} = 0V$	1	+25°C	-0.75	0.75	mV
			2, 3	+125°C, -55°C	-1.5	1.5	mV
Input Bias Current	+ I_B	$V_{CM} = 0V$, + $R_S = 100.1k\Omega$, - $R_S = 100\Omega$	1	+25°C	-80	80	nA
			2, 3	+125°C, -55°C	-200	200	nA
	- I_B	$V_{CM} = 0V$, + $R_S = 100\Omega$, - $R_S = 100.1k\Omega$	1	+25°C	-80	80	nA
			2, 3	+125°C, -55°C	-200	200	nA
Input Offset Current	I_{IO}	$V_{CM} = 0V$, + $R_S = 100.1k\Omega$, - $R_S = 100.1k\Omega$	1	+25°C	-50	50	nA
			2, 3	+125°C, -55°C	-150	150	nA
Common Mode Range	+CMR	$V+ = +3V$, $V- = -27V$	1	+25°C	12	-	V
			2, 3	+125°C, -55°C	12	-	V
	-CMR	$V+ = +27V$, $V- = -3V$	1	+25°C	-	-12	V
			2, 3	+125°C, -55°C	-	-12	V
Large Signal Voltage Gain	+ A_{VOL}	$V_{OUT} = 0V$ and +10V	4	+25°C	106	-	dB
			5, 6	+125°C, -55°C	100	-	dB
	- A_{VOL}	$V_{OUT} = 0V$ and -10V	4	+25°C	106	-	dB
			5, 6	+125°C, -55°C	100	-	dB
Common Mode Rejection Ratio	+CMRR	$\Delta V_{CM} = +10V$, $V+ = +5V$, $V- = -25V$, $V_{OUT} = -10V$	1	+25°C	88	-	dB
			2, 3	+125°C, -55°C	86	-	dB
	-CMRR	$\Delta V_{CM} = -10V$, $V+ = +25V$, $V- = -5V$, $V_{OUT} = +10V$	1	+25°C	88	-	dB
			2, 3	+125°C, -55°C	86	-	dB
Output Voltage Swing	+ V_{OUT}	$R_L = 1k\Omega$	4	+25°C	12.0	-	V
			5, 6	+125°C, -55°C	11.5	-	V
	- V_{OUT}	$R_L = 1k\Omega$	4	+25°C	-	-12.0	V
			5, 6	+125°C, -55°C	-	-11.5	V

Specifications HA-5222/883

TABLE 1. DC ELECTRICAL PERFORMANCE CHARACTERISTICS (Continued)

Device Tested at: $V_{SUPPLY} = \pm 15V$, $R_{LOAD} = 1k\Omega$, $V_{OUT} = 0V$, Unless Otherwise Specified.

PARAMETERS	SYMBOL	CONDITIONS	GROUP A SUBGROUPS	TEMPERATURE	LIMITS		UNITS
					MIN	MAX	
Output Current	+I _{OUT}	V _{OUT} = +10V, R _L = 1kΩ	4	+25°C	30	-	mA
			5, 6	+125°C, -55°C	30	-	mA
	-I _{OUT}	V _{OUT} = -10V, R _L = 1kΩ	4	+25°C	-	-30	mA
			5, 6	+125°C, -55°C	-	-30	mA
Quiescent Power Supply Current	+I _{CC}	V _{OUT} = 0V, I _{OUT} = 0mA	1	+25°C	-	20	mA
			2, 3	+125°C, -55°C	-	22	mA
	-I _{CC}	V _{OUT} = 0V, I _{OUT} = 0mA	1	+25°C	-20	-	mA
			2, 3	+125°C, -55°C	-22	-	mA
Power Supply Rejection Ratio	+PSRR	ΔV _{SUP} = 10V, V ₊ = +20V, V ₋ = -15V, V ₊ = +10V, V ₋ = -15V	1	+25°C	90	-	dB
			2, 3	+125°C, -55°C	86	-	dB
	-PSRR	ΔV _{SUP} = 10V, V ₊ = +15V, V ₋ = -20V, V ₊ = +15V, V ₋ = -10V	1	+25°C	90	-	dB
			2, 3	+125°C, -55°C	86	-	dB

TABLE 2. AC ELECTRICAL PERFORMANCE CHARACTERISTICS

Table 2 Intentionally Left Blank. See AC Specifications in Table 3.

TABLE 3. ELECTRICAL PERFORMANCE CHARACTERISTIC

Device Characterized at: $V_{SUPPLY} = \pm 15V$, $R_{LOAD} = 1k\Omega$, Unless Otherwise Specified.

PARAMETERS	SYMBOL	CONDITIONS	NOTES	TEMPERATURE	LIMITS		UNITS
					MIN	MAX	
Input Noise Voltage Density	E _N	R _S = 0Ω, f _O = 10Hz	1, 5	+25°C	-	16.0	nV/√Hz
		R _S = 0Ω, f _O = 100Hz	1, 5	+25°C	-	6.6	nV/√Hz
		R _S = 0Ω, f _O = 1kHz	1, 5	+25°C	-	5.9	nV/√Hz
Input Noise Current Density	I _N	R _S = 500kΩ, f _O = 10Hz	1, 5	+25°C	-	24.0	pA/√Hz
		R _S = 500kΩ, f _O = 100Hz	1, 5	+25°C	-	6.6	pA/√Hz
		R _S = 500kΩ, f _O = 1kHz	1, 5	+25°C	-	2.7	pA/√Hz
Gain Bandwidth Product	GBWP	V _{OUT} = 200mV _{P-P} , f _O = 100kHz	1	+25°C	100	-	MHz
				-55°C to +125°C	88	-	MHz
Unity Gain Bandwidth	UGBW	V _{OUT} = 200mV	1	+25°C	30	-	MHz
				-55°C to +125°C	25	-	MHz
Slew Rate	±SR	V _{OUT} = ±2.5V, C _L = 50pF	1	-55°C to +125°C	25	-	V/μs
Full Power Bandwidth	FPBW	V _{PEAK} = 10V	1, 2	-55°C to +125°C	398	-	kHz

Specifications HA-5222/883

TABLE 3. ELECTRICAL PERFORMANCE CHARACTERISTIC (Continued)

Device Characterized at: $V_{SUPPLY} = \pm 15V$, $R_{LOAD} = 1k\Omega$, Unless Otherwise Specified.

PARAMETERS	SYMBOL	CONDITIONS	NOTES	TEMPERATURE	LIMITS		UNITS
					MIN	MAX	
Minimum Closed Loop Stable Gain	CLSG	$R_L = 1k\Omega$, $C_L = 50pF$	1	-55°C to +125°C	1	-	V/V
Rise and Fall Time	t_R, t_F	$V_{OUT} = \pm 100mV$	1, 4	+25°C	-	20	ns
				-55°C to +125°C	-	35	ns
Overshoot	$\pm OS$	$V_{OUT} = \pm 100mV$	1	+25°C	-	25	%
				-55°C to +125°C	-	30	%
Power Consumption	PC	$V_{OUT} = 0V$, $I_{OUT} = 0mA$	1, 3	-55°C to +125°C	-	660	mW

NOTES:

1. Parameters listed in Table 3 are controlled via design or process parameters and are not directly tested at final production. These parameters are lab characterized upon initial design release, or upon design changes. These parameters are guaranteed by characterization based upon data from multiple production runs which reflect lot to lot and within lot variation.
2. Full Power Bandwidth guarantee based on Slew Rate measurement using $FPBW = \text{Slew Rate}/(2\pi V_{PEAK})$.
3. Power Consumption based upon Quiescent Supply Current test maximum. (No load on outputs.).
4. Measured between 10% and 90% points.
5. Input Noise Voltage Density and Input Noise Current Density limits are based on characterization data.

TABLE 4. ELECTRICAL TEST REQUIREMENTS

MIL-STD-883 TEST REQUIREMENTS	SUBGROUPS (SEE TABLE 1)
Interim Electrical Parameters (Pre Burn-In)	1
Final Electrical Test Parameters	1 (Note 1), 2, 3, 4, 5, 6
Group A Test Requirements	1, 2, 3, 4, 5, 6
Groups C and D Endpoints	1

NOTE:

1. PDA applies to Subgroup 1 only.

Die Characteristics

DIE DIMENSIONS:

78 x 185 x 19 mils \pm 1 mils
 1980 x 4690 x 483 μ m \pm 25.4 μ m

METALLIZATION:

Type: Al, 1% Cu
 Thickness: 16k \AA \pm 2k \AA

GLASSIVATION:

Type: Nitride (Si₃N₄) over Silox (SiO₂ 5% Phos.)
 Silox Thickness: 12k \AA \pm 2k \AA
 Nitride Thickness: 3.5k \AA \pm 1.5k \AA

WORST CASE CURRENT DENSITY:

4.2 x 10⁴ A/cm²

SUBSTRATE POTENTIAL (Powered Up): V-

TRANSISTOR COUNT: 128

PROCESS: Bipolar Dielectric Isolation

Metallization Mask Layout

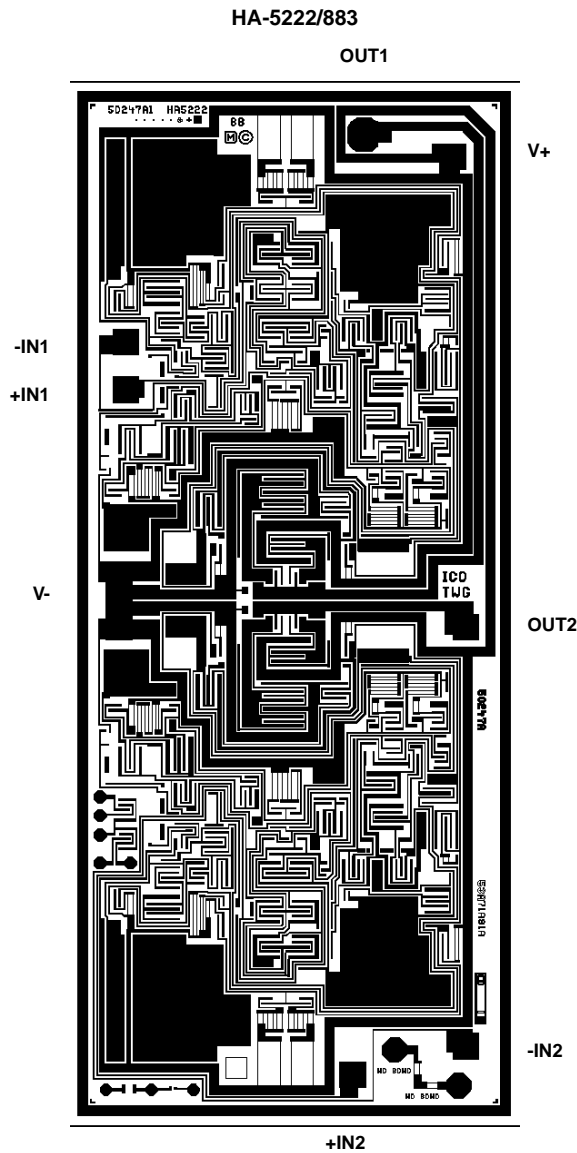

DESIGN INFORMATION (Continued)

The information contained in this section has been developed through characterization by Harris Semiconductor and is for use as application and design information only. No guarantee is implied.

Typical Performance Curves Unless Otherwise Specified: $T_A = +25^\circ\text{C}$, $V_{\text{SUPPLY}} = \pm 15\text{V}$

SUPPLY CURRENT/AMPLIFIER vs TEMPERATURE

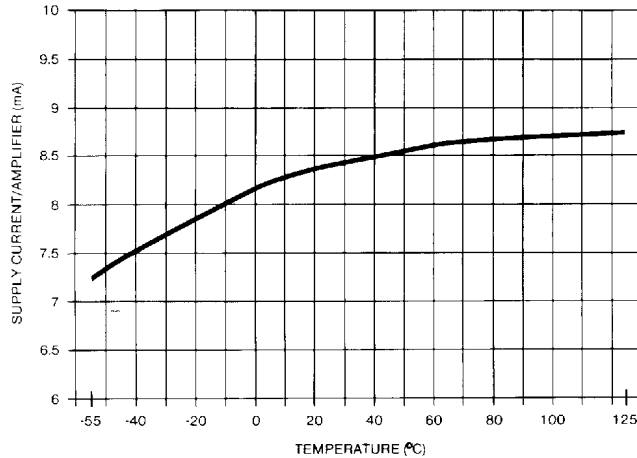

CHANNEL SEPARATION vs FREQUENCY

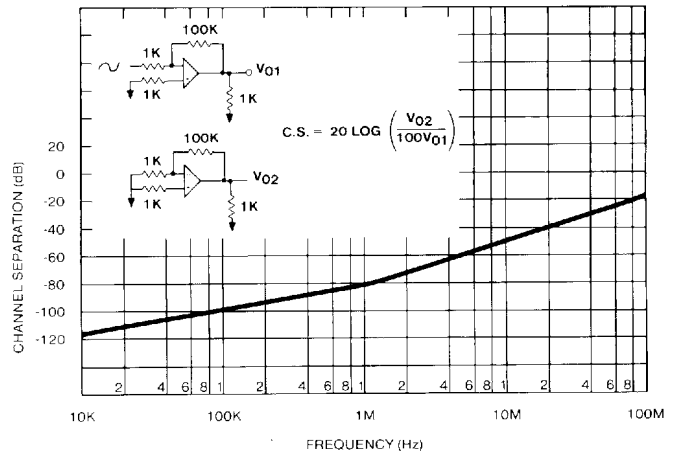

TYPICAL PERFORMANCE CHARACTERISTICS

Device Characterized at: Supply Voltage = $\pm 15\text{V}$, $R_L = 1\text{k}\Omega$, $C_L = 50\text{pF}$, Unless Otherwise Specified

PARAMETERS	CONDITIONS	TEMPERATURE	TYPICAL	UNITS
Input Offset Voltage	See Table 1	+25°C	0.30	mV
		Full	0.35	mV
Average Offset Voltage Drift	See Table 1	Full	0.50	$\mu\text{V}/^\circ\text{C}$
Input Bias Current	See Table 1	+25°C	40	nA
		Full	70	nA
Input Offset Current	See Table 1	+25°C	15	nA
		Full	30	nA
Differential Input Resistance	See Table 1	+25°C	70	k Ω
Input Noise Voltage	$f_O = 0.1\text{Hz}$ to 10Hz	+25°C	0.33	$\mu\text{V}_{\text{P-P}}$
Input Noise Voltage Density	$f_O = 10\text{Hz}$	+25°C	6.4	$\text{nV}/\sqrt{\text{Hz}}$
	$f_O = 100\text{Hz}$	+25°C	3.7	$\text{nV}/\sqrt{\text{Hz}}$
	$f_O = 1\text{kHz}$	+25°C	3.3	$\text{nV}/\sqrt{\text{Hz}}$
Input Noise Current Density	$f_O = 10\text{Hz}$	+25°C	8	$\text{pA}/\sqrt{\text{Hz}}$
	$f_O = 100\text{Hz}$	+25°C	2.7	$\text{pA}/\sqrt{\text{Hz}}$
	$f_O = 1\text{kHz}$	+25°C	1.3	$\text{pA}/\sqrt{\text{Hz}}$
THD & N	See Note 1	+25°C	0.005	%
Large Signal Voltage Gain	$V_{\text{OUT}} = 0\text{V}$ to $\pm 10\text{V}$	+25°C	128	dB
		Full	120	dB

DESIGN INFORMATION (Continued)

The information contained in this section has been developed through characterization by Harris Semiconductor and is for use as application and design information only. No guarantee is implied.

TYPICAL PERFORMANCE CHARACTERISTICS (Continued)

Device Characterized at: Supply Voltage = $\pm 15V$, $R_L = 1k\Omega$, $C_L = 50pF$, Unless Otherwise Specified

PARAMETERS	CONDITIONS	TEMPERATURE	TYPICAL	UNITS	
Common Mode Rejection Ratio	$\Delta V_{CM} = \pm 10V$	Full	95	dB	
Unity Gain Bandwidth	-3dB	+25°C	40	MHz	
		+125°C	33	MHz	
		-55°C	50	MHz	
Gain Bandwidth Product	1kHz to 400kHz	+25°C	140	MHz	
		+125°C	115	MHz	
		-55°C	160	MHz	
Minimum Gain Stability		Full	1	V/V	
Output Voltage Swing	$R_L = 333\Omega$	Full	110	V	
	$R_L = 1K$	+25°C	112.5	V	
		Full	112.1	V	
Output Current	$V_{OUT} = \pm 10V$	Full	156	mA	
Output Resistance		+25°C	10	V	
Full Power Bandwidth	FPBW = $SR/2\pi V_{PEAK}$, $V_{PEAK} = 10V$	+25°C	398	kHz	
Channel Separation	$f_O = 10kHz$	+25°C	110	dB	
Slew Rate	$V_{OUT} = \pm 2.5V$	+25°C	37	V/ μs	
		+125°C	39	V/ μs	
		-55°C	36	V/ μs	
Rise Time	$V_{OUT} = \pm 100mV$	+25°C	16	ns	
		+125°C	17	ns	
		-55°C	17	ns	
Overshoot	$V_{OUT} = \pm 100mV$	+25°C	12	%	
		+125°C	11	%	
		-55°C	12	%	
Settling Time	$10V_{STEP}$ $A_V = -1$	0.1%	+25°C	0.4	μs
		0.01%	+25°C	1.5	μs
Power Supply Rejection Ratio	$\Delta V_S = \pm 10V$ to $\pm 20V$	Full	100	dB	
Supply Current	Quiescent, $V_{OUT} = 0V$, $I_{OUT} = 0mA$	Full	8	mA/Op Amp	
Minimum Supply Voltage	Functional Operation Only. Other Parameters May Vary.	+25°C	15	V	

NOTE:

- $A_{VCL} = 10$, $f_O = 1kHz$, $V_{OUT} = 5V_{rms}$, $R_L = 600\Omega$, 10Hz to 100kHz, Minimum resolution of test equipment is 0.005%.

All Intersil semiconductor products are manufactured, assembled and tested under **ISO9000** quality systems certification.

Intersil products are sold by description only. Intersil Corporation reserves the right to make changes in circuit design and/or specifications at any time without notice. Accordingly, the reader is cautioned to verify that data sheets are current before placing orders. Information furnished by Intersil is believed to be accurate and reliable. However, no responsibility is assumed by Intersil or its subsidiaries for its use; nor for any infringements of patents or other rights of third parties which may result from its use. No license is granted by implication or otherwise under any patent or patent rights of Intersil or its subsidiaries.

For information regarding Intersil Corporation and its products, see web site <http://www.intersil.com>

Sales Office Headquarters

NORTH AMERICA

Intersil Corporation
P. O. Box 883, Mail Stop 53-204
Melbourne, FL 32902
TEL: (321) 724-7000
FAX: (321) 724-7240

EUROPE

Intersil SA
Mercure Center
100, Rue de la Fusee
1130 Brussels, Belgium
TEL: (32) 2.724.2111
FAX: (32) 2.724.22.05

ASIA

Intersil (Taiwan) Ltd.
Taiwan Limited
7F-6, No. 101 Fu Hsing North Road
Taipei, Taiwan
Republic of China
TEL: (886) 2 2716 9310
FAX: (886) 2 2715 3029

This datasheet has been downloaded from:

www.DatasheetCatalog.com

Datasheets for electronic components.



LittleDiode supplies new, hard to find or obsolete electronic components and semiconductors all over the world.

With over two million different components listed you are sure to find the part you need.

Feel free to visit us today at our online store:

LittleDiode.com

Looking forward to providing you with the best possible service.