

---

# HA178M00 Series

## 3-terminal Fixed Voltage Regulators

# HITACHI

---

### Features

- Output current less than 500 mA
- Various output voltages: 5, 6, 7, 8, 9, 12, 15, 18, 20, and 24 V
- No external compensation circuit required
- Built-in current control circuit protects elements from destruction by short circuit
- Building chip junction temperature limiting circuit protects elements from thermal destruction
- Building internal power dissipation limiting circuit protects transistors in output stage

### Ordering Information

Type	Application	Package
HA178M00PJ Series	Automotive use	TO - 220AB
HA178M00P Series	Industrial use	
HA178M00 Series	Commercial use	

### Output Voltage Accuracy Grade

Type No.	Grade	Accuracy
HA178M05	None	$\pm 4$
HA178M12	A	$\pm 2$
	B	$\pm 3$
	C	+2, -4

# HA178M00 Series

## Pin Arrangement

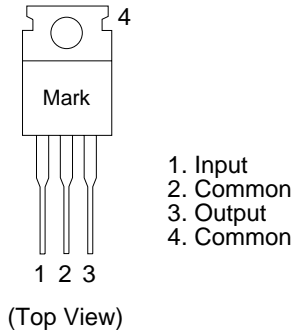

## Block Diagram

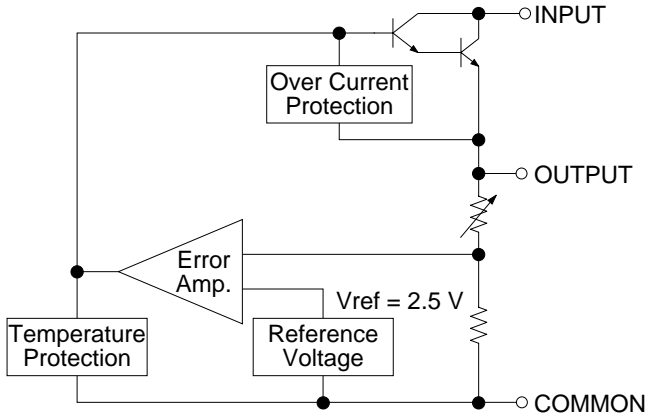

## Standard Circuit

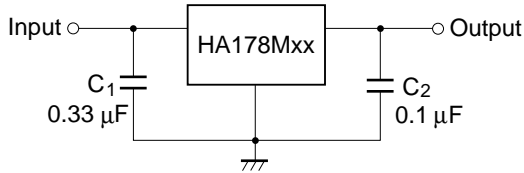

HITACHI

## Absolute Maximum Ratings ( $T_a = 25^\circ\text{C}$ )

Item	Symbol	Rating	Unit	Notes
Input voltage	$V_{IN}$	35	V	1
Input voltage	$V_{IN}$	40	V	2
Power dissipation	$P_T$	7.5	W	3
Operating temperature	$T_{opr}$	-20 to +75	$^\circ\text{C}$	
Junction temperature	$T_j$	-20 to +125	$^\circ\text{C}$	
Storage temperature	$T_{stg}$	-55 to +125	$^\circ\text{C}$	

- Notes: 1. For HA178M05P–HA178M18P, HA178M05–HA178M18  
 2. For HA178M20P, HA178M24P, HA178M20, HA178M24  
 3. Follow derating curve

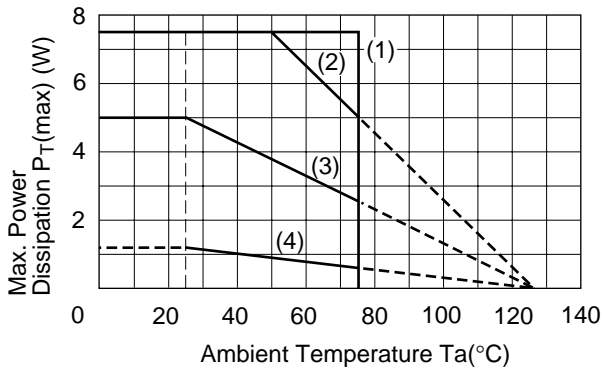

- (1) Infinite heat sink  
 (2) 5 $^\circ\text{C}/\text{W}$  heat sink  
 (3) 15 $^\circ\text{C}/\text{W}$  heat sink  
 (4) No heat sink
- ) Include fixed thermal resistance

Thermal resistance  
 $\theta_{jc} = 3.0^\circ\text{C}/\text{W}$  (typ)  
 5.0 $^\circ\text{C}/\text{W}$  (max)  
 $\theta_{ja} = 62^\circ\text{C}/\text{W}$  (typ)  
 72 $^\circ\text{C}/\text{W}$  (max)

# HA178M00 Series

**HA178M05P/PJ, HA178M05 Electrical Characteristics** ( $V_{IN} = 10\text{ V}$ ,  $I_{OUT} = 350\text{ mA}$ ,  $0^\circ\text{C} \leq T_j \leq 125^\circ\text{C}$ ,  $C_{IN} = 0.33\text{ }\mu\text{F}$ ,  $C_{OUT} = 0.1\text{ }\mu\text{F}$ , unless otherwise specified)

Item	Symbol	Min	Typ	Max	Unit	Test Conditions
Output voltage	$V_{OUT}$	4.8	5.0	5.2	V	$T_j = 25^\circ\text{C}$
		4.75	—	5.25		$7\text{ V} \leq V_{IN} \leq 20\text{ V}$ , $5\text{ mA} \leq I_{OUT} \leq 350\text{ mA}$ , $P_T \leq 7.5\text{ W}$
Line regulation	$\delta V_{OLine}$	—	3	100	mV	$T_j = 25^\circ\text{C}$ $7\text{ V} \leq V_{IN} \leq 25\text{ V}$ , $I_{OUT} = 200\text{ mA}$
		—	1	50		$8\text{ V} \leq V_{IN} \leq 25\text{ V}$ , $I_{OUT} = 200\text{ mA}$
Load regulation	$\delta V_{OLoad}$	—	20	100	mV	$T_j = 25^\circ\text{C}$ $5\text{ mA} \leq I_{OUT} \leq 500\text{ mA}$
		—	10	50		$5\text{ mA} \leq I_{OUT} \leq 200\text{ mA}$
Quiescent current	$I_Q$	—	4.5	6.0	mA	$T_j = 25^\circ\text{C}$ , $I_{OUT} = 0$
Quiescent current change	$\delta I_Q$	—	—	0.8	mA	$8\text{ V} \leq V_{IN} \leq 25\text{ V}$ , $I_{OUT} = 200\text{ mA}$
		—	—	0.5		$5\text{ mA} \leq I_{OUT} \leq 350\text{ mA}$
Output noise voltage	$V_n$	—	40	—	$\mu\text{V}$	$T_a = 25^\circ\text{C}$ , $10\text{ Hz} \leq f \leq 100\text{ kHz}$
Ripple rejection ratio	$R_{REJ}$	—	80	—	dB	$f = 120\text{ Hz}$ $I_{OUT} = 100\text{ mA}$
		—	80	—		$T_j = 25^\circ\text{C}$ $I_{OUT} = 300\text{ mA}$
Dropout voltage	$V_{drop}$	—	2.0	—	V	$I_{OUT} = 350\text{ mA}$ , $T_j = 25^\circ\text{C}$
Output short-circuit current	$I_{OS}$	—	300	—	mA	$T_j = 25^\circ\text{C}$ , $V_{IN} = 35\text{ V}$
Peak output current	$I_{o\text{ peak}}$	—	700	—	mA	$T_j = 25^\circ\text{C}$
Temperature coefficient of output voltage	$\delta V_{OUT}/\delta T_j$	—	-1.0	—	mV/°C	$I_{OUT} = 5\text{ mA}$ , $0^\circ\text{C} \leq T_j \leq 125^\circ\text{C}$

**HA178M06P/PJ, HA178M06 Electrical Characteristics** ( $V_{IN} = 11\text{ V}$ ,  $I_{OUT} = 350\text{ mA}$ ,  $0^\circ\text{C} \leq T_j \leq 125^\circ\text{C}$ ,  $C_{IN} = 0.33\ \mu\text{F}$ ,  $C_{OUT} = 0.1\ \mu\text{F}$ , unless otherwise specified)

Item	Symbol	Min	Typ	Max	Unit	Test Conditions
Output voltage	$V_{OUT}$	5.75	6.0	6.25	V	$T_j = 25^\circ\text{C}$
		5.7	—	6.3		$8\text{ V} \leq V_{IN} \leq 21\text{ V}$ , $5\text{ mA} \leq I_{OUT} \leq 350\text{ mA}$ , $P_T \leq 7.5\text{ W}$
Line regulation	$\delta V_{O\text{Line}}$	—	5	120	mV	$T_j = 25^\circ\text{C}$ $8\text{ V} \leq V_{IN} \leq 25\text{ V}$ , $I_{OUT} = 200\text{ mA}$
		—	1.5	60		$9\text{ V} \leq V_{IN} \leq 25\text{ V}$ , $I_{OUT} = 200\text{ mA}$
Load regulation	$\delta V_{O\text{Load}}$	—	20	120	mV	$T_j = 25^\circ\text{C}$ $5\text{ mA} \leq I_{OUT} \leq 500\text{ mA}$
		—	10	60		$5\text{ mA} \leq I_{OUT} \leq 200\text{ mA}$
Quiescent current	$I_Q$	—	4.5	6.0	mA	$T_j = 25^\circ\text{C}$ , $I_{OUT} = 0$
Quiescent current change	$\delta I_Q$	—	—	0.8		$9\text{ V} \leq V_{IN} \leq 25\text{ V}$ , $I_{OUT} = 200\text{ mA}$
		—	—	0.5	$5\text{ mA} \leq I_{OUT} \leq 350\text{ mA}$	
Output noise voltage	$V_n$	—	45	—	$\mu\text{V}$	$T_a = 25^\circ\text{C}$ , $10\text{ Hz} \leq f \leq 100\text{ kHz}$
Ripple rejection ratio	$R_{REJ}$	—	80	—	dB	$f = 120\text{ Hz}$ $I_{OUT} = 100\text{ mA}$
		—	80	—		$T_j = 25^\circ\text{C}$ $I_{OUT} = 300\text{ mA}$
Dropout voltage	$V_{drop}$	—	2.0	—	V	$I_{OUT} = 350\text{ mA}$ , $T_j = 25^\circ\text{C}$
Output short-circuit current	$I_{OS}$	—	270	—	mA	$T_j = 25^\circ\text{C}$ , $V_{IN} = 35\text{ V}$
Peak output current	$I_{o\text{ peak}}$	—	700	—	mA	$T_j = 25^\circ\text{C}$
Temperature coefficient of output voltage	$\delta V_{OUT}/\delta V_j$	—	-0.5	—	mV/°C	$I_{OUT} = 5\text{ mA}$ , $0^\circ\text{C} \leq T_j \leq 125^\circ\text{C}$

# HA178M00 Series

**HA178M07P/PJ, HA178M07 Electrical Characteristics** ( $V_{IN} = 12.5\text{ V}$ ,  $I_{OUT} = 350\text{ mA}$ ,  $0^\circ\text{C} \leq T_j \leq 125^\circ\text{C}$ ,  $C_{IN} = 0.33\ \mu\text{F}$ ,  $C_{OUT} = 0.1\ \mu\text{F}$ , unless otherwise specified)

Item	Symbol	Min	Typ	Max	Unit	Test Conditions
Output voltage	$V_{OUT}$	6.72	7.0	7.28	V	$T_j = 25^\circ\text{C}$
		6.65	—	7.35		$9\text{ V} \leq V_{IN} \leq 22\text{ V}$ , $5\text{ mA} \leq I_{OUT} \leq 350\text{ mA}$ , $P_T \leq 7.5\text{ W}$
Line regulation	$\delta V_{OLine}$	—	5.5	140	mV	$T_j = 25^\circ\text{C}$ $9\text{ V} \leq V_{IN} \leq 25\text{ V}$ , $I_{OUT} = 200\text{ mA}$
		—	1.7	70		$10\text{ V} \leq V_{IN} \leq 25\text{ V}$ , $I_{OUT} = 200\text{ mA}$
Load regulation	$\delta V_{OLoad}$	—	23	140	mV	$T_j = 25^\circ\text{C}$ $5\text{ mA} \leq I_{OUT} \leq 500\text{ mA}$
		—	10	70		$5\text{ mA} \leq I_{OUT} \leq 200\text{ mA}$
Quiescent current	$I_Q$	—	4.6	6.0	mA	$T_j = 25^\circ\text{C}$ , $I_{OUT} = 0$
Quiescent current change	$\delta I_Q$	—	—	0.8	mA	$10\text{ V} \leq V_{IN} \leq 25\text{ V}$ , $I_{OUT} = 200\text{ mA}$
		—	—	0.5		$5\text{ mA} \leq I_{OUT} \leq 350\text{ mA}$
Output noise voltage	$V_n$	—	48.5	—	$\mu\text{V}$	$T_a = 25^\circ\text{C}$ , $10\text{ Hz} \leq f \leq 100\text{ kHz}$
Ripple rejection ratio	$R_{REJ}$	—	80	—	dB	$f = 120\text{ Hz}$ $I_{OUT} = 100\text{ mA}$
		—	80	—		$T_j = 25^\circ\text{C}$ $I_{OUT} = 300\text{ mA}$
Dropout voltage	$V_{drop}$	—	2.0	—	V	$I_{OUT} = 350\text{ mA}$ , $T_j = 25^\circ\text{C}$
Output short-circuit current	$I_{OS}$	—	260	—	mA	$T_j = 25^\circ\text{C}$ , $V_{IN} = 35\text{ V}$
Peak output current	$I_{o\ peak}$	—	700	—	mA	$T_j = 25^\circ\text{C}$
Temperature coefficient of output voltage	$\delta V_{OUT}/\delta T_j$	—	-0.5	—	mV/°C	$I_{OUT} = 5\text{ mA}$ , $0^\circ\text{C} \leq T_j \leq 125^\circ\text{C}$

**HA178M08P/PJ, HA178M08 Electrical Characteristics** ( $V_{IN} = 14\text{ V}$ ,  $I_{OUT} = 350\text{ mA}$ ,  $0^\circ\text{C} \leq T_j \leq 125^\circ\text{C}$ ,  $C_{IN} = 0.33\text{ }\mu\text{F}$ ,  $C_{OUT} = 0.1\text{ }\mu\text{F}$ , unless otherwise specified)

Item	Symbol	Min	Typ	Max	Unit	Test Conditions
Output voltage	$V_{OUT}$	7.7 7.6	8.0 —	8.3 8.4	V	$T_j = 25^\circ\text{C}$ $10.5\text{ V} \leq V_{IN} \leq 23\text{ V}$ , $5\text{ mA} \leq I_{OUT} \leq 350\text{ mA}$ , $P_T \leq 7.5\text{ W}$
Line regulation	$\delta V_{O\text{Line}}$	— —	6.0 2.0	160 80	mV	$T_j = 25^\circ\text{C}$ $10.5\text{ V} \leq V_{IN} \leq 25\text{ V}$ , $I_{OUT} = 200\text{ mA}$ $11\text{ V} \leq V_{IN} \leq 25\text{ V}$ , $I_{OUT} = 200\text{ mA}$
Load regulation	$\delta V_{O\text{Load}}$	— —	25 10	160 80	mV	$T_j = 25^\circ\text{C}$ $5\text{ mA} \leq I_{OUT} \leq 500\text{ mA}$ $5\text{ mA} \leq I_{OUT} \leq 200\text{ mA}$
Quiescent current	$I_Q$	—	4.6	6.0	mA	$T_j = 25^\circ\text{C}$ , $I_{OUT} = 0$
Quiescent current change	$\delta I_Q$	— —	— —	0.8 0.5	mA	$10.5\text{ V} \leq V_{IN} \leq 25\text{ V}$ , $I_{OUT} = 200\text{ mA}$ $5\text{ mA} \leq I_{OUT} \leq 350\text{ mA}$
Output noise voltage	$V_n$	—	52	—	$\mu\text{V}$	$T_a = 25^\circ\text{C}$ , $10\text{ Hz} \leq f \leq 100\text{ kHz}$
Ripple rejection ratio	$R_{REJ}$	— —	80 80	— —	dB	$f = 120\text{ Hz}$ $T_j = 25^\circ\text{C}$ $I_{OUT} = 100\text{ mA}$ $I_{OUT} = 300\text{ mA}$
Dropout voltage	$V_{drop}$	—	2.0	—	V	$I_{OUT} = 350\text{ mA}$ , $T_j = 25^\circ\text{C}$
Output short-circuit current	$I_{OS}$	—	250	—	mA	$T_j = 25^\circ\text{C}$ , $V_{IN} = 35\text{ V}$
Peak output current	$I_{o\text{ peak}}$	—	700	—	mA	$T_j = 25^\circ\text{C}$
Temperature coefficient of output voltage	$\delta V_{OUT}/\delta T_j$	—	-0.5	—	mV/ $^\circ\text{C}$	$I_{OUT} = 5\text{ mA}$ , $0^\circ\text{C} \leq T_j \leq 125^\circ\text{C}$

# HA178M00 Series

**HA178M09P/PJ, HA178M09 Electrical Characteristics** ( $V_{IN} = 15\text{ V}$ ,  $I_{OUT} = 350\text{ mA}$ ,  $0^\circ\text{C} \leq T_j \leq 125^\circ\text{C}$ ,  $C_{IN} = 0.33\text{ }\mu\text{F}$ ,  $C_{OUT} = 0.1\text{ }\mu\text{F}$ , unless otherwise specified)

Item	Symbol	Min	Typ	Max	Unit	Test Conditions
Output voltage	$V_{OUT}$	8.64	9.0	9.36	V	$T_j = 25^\circ\text{C}$
		8.55	—	9.45		$11.5\text{ V} \leq V_{IN} \leq 24\text{ V}$ , $5\text{ mA} \leq I_{OUT} \leq 350\text{ mA}$ , $P_T \leq 7.5\text{ W}$
Line regulation	$\delta V_{O\text{Line}}$	—	7.0	180	mV	$T_j = 25^\circ\text{C}$ $11.5\text{ V} \leq V_{IN} \leq 25\text{ V}$ , $I_{OUT} = 200\text{ mA}$
		—	2.5	90		$12\text{ V} \leq V_{IN} \leq 25\text{ V}$ $I_{OUT} = 200\text{ mA}$
Load regulation	$\delta V_{O\text{Load}}$	—	25	200	mV	$T_j = 25^\circ\text{C}$ $5\text{ mA} \leq I_{OUT} \leq 500\text{ mA}$
		—	10	100		$5\text{ mA} \leq I_{OUT} \leq 200\text{ mA}$
Quiescent current	$I_Q$	—	4.6	6.0	mA	$T_j = 25^\circ\text{C}$ , $I_{OUT} = 0$
Quiescent current change	$\delta I_Q$	—	—	0.8	mA	$12\text{ V} \leq V_{IN} \leq 25\text{ V}$ , $I_{OUT} = 200\text{ mA}$
		—	—	0.5		$5\text{ mA} \leq I_{OUT} \leq 350\text{ mA}$
Output noise voltage	$V_n$	—	52	—	$\mu\text{V}$	$T_a = 25^\circ\text{C}$ , $10\text{ Hz} \leq f \leq 100\text{ kHz}$
Ripple rejection ratio	$R_{REJ}$	—	80	—	dB	$f = 120\text{ Hz}$ $I_{OUT} = 100\text{ mA}$
		—	80	—		$T_j = 25^\circ\text{C}$ $I_{OUT} = 300\text{ mA}$
Dropout voltage	$V_{drop}$	—	2.0	—	V	$I_{OUT} = 350\text{ mA}$ , $T_j = 25^\circ\text{C}$
Output short-circuit current	$I_{OS}$	—	250	—	mA	$T_j = 25^\circ\text{C}$ , $V_{IN} = 35\text{ V}$
Peak output current	$I_{o\text{ peak}}$	—	700	—	mA	$T_j = 25^\circ\text{C}$
Temperature coefficient of output voltage	$\delta V_{OUT}/\delta T_j$	—	-0.9	—	mV/°C	$I_{OUT} = 5\text{ mA}$ , $0^\circ\text{C} \leq T_j \leq 125^\circ\text{C}$

**HA178M12P/PJ, HA178M12 Electrical Characteristics** ( $V_{IN} = 19\text{ V}$ ,  $I_{OUT} = 350\text{ mA}$ ,  $0^\circ\text{C} \leq T_j \leq 125^\circ\text{C}$ ,  $C_{IN} = 0.33\text{ }\mu\text{F}$ ,  $C_{OUT} = 0.1\text{ }\mu\text{F}$ , unless otherwise specified)

Item	Symbol	Min	Typ	Max	Unit	Test Conditions
Output voltage	$V_{OUT}$	11.5	12.0	12.5	V	$T_j = 25^\circ\text{C}$
		11.4	—	12.6		$14.5\text{ V} \leq V_{IN} \leq 27\text{ V}$ , $5\text{ mA} \leq I_{OUT} \leq 350\text{ mA}$ , $P_T \leq 7.5\text{ W}$
Line regulation	$\delta V_{O\text{Line}}$	—	10	240	mV	$T_j = 25^\circ\text{C}$ $14.5\text{ V} \leq V_{IN} \leq 30\text{ V}$ , $I_{OUT} = 200\text{ mA}$
		—	3.0	120		$16\text{ V} \leq V_{IN} \leq 30\text{ V}$ , $I_{OUT} = 200\text{ mA}$
Load regulation	$\delta V_{O\text{Load}}$	—	25	240	mV	$T_j = 25^\circ\text{C}$ $5\text{ mA} \leq I_{OUT} \leq 500\text{ mA}$
		—	10	120		$5\text{ mA} \leq I_{OUT} \leq 200\text{ mA}$
Quiescent current	$I_Q$	—	4.8	6.0	mA	$T_j = 25^\circ\text{C}$ , $I_{OUT} = 0$
Quiescent current change	$\delta I_Q$	—	—	0.8	mA	$14.5\text{ V} \leq V_{IN} \leq 30\text{ V}$ , $I_{OUT} = 200\text{ mA}$
		—	—	0.5		$5\text{ mA} \leq I_{OUT} \leq 350\text{ mA}$
Output noise voltage	$V_n$	—	75	—	$\mu\text{V}$	$T_a = 25^\circ\text{C}$ , $10\text{ Hz} \leq f \leq 100\text{ kHz}$
Ripple rejection ratio	$R_{REJ}$	—	80	—	dB	$f = 120\text{ Hz}$ $I_{OUT} = 100\text{ mA}$
		—	80	—		$T_j = 25^\circ\text{C}$ $I_{OUT} = 300\text{ mA}$
Dropout voltage	$V_{drop}$	—	2.0	—	V	$I_{OUT} = 350\text{ mA}$ , $T_j = 25^\circ\text{C}$
Output short-circuit current	$I_{OS}$	—	240	—	mA	$T_j = 25^\circ\text{C}$ , $V_{IN} = 35\text{ V}$
Peak output current	$I_{o\text{ peak}}$	—	700	—	mA	$T_j = 25^\circ\text{C}$
Temperature coefficient of output voltage	$\delta V_{OUT}/\delta T_j$	—	-1.0	—	mV/°C	$I_{OUT} = 5\text{ mA}$ , $0^\circ\text{C} \leq T_j \leq 125^\circ\text{C}$

# HA178M00 Series

**HA178M15P/PJ, HA178M15 Electrical Characteristics** ( $V_{IN} = 23\text{ V}$ ,  $I_{OUT} = 350\text{ mA}$ ,  $0^\circ\text{C} \leq T_j \leq 125^\circ\text{C}$ ,  $C_{IN} = 0.33\ \mu\text{F}$ ,  $C_{OUT} = 0.1\ \mu\text{F}$ , unless otherwise specified)

Item	Symbol	Min	Typ	Max	Unit	Test Conditions
Output voltage	$V_{OUT}$	14.4	15.0	15.6	V	$T_j = 25^\circ\text{C}$
		14.25	—	15.75		$17.5\text{ V} \leq V_{IN} \leq 30\text{ V}$ , $5\text{ mA} \leq I_{OUT} \leq 350\text{ mA}$ , $P_T \leq 7.5\text{ W}$
Line regulation	$\delta V_{O\text{Line}}$	—	11	300	mV	$T_j = 25^\circ\text{C}$ $17.5\text{ V} \leq V_{IN} \leq 30\text{ V}$ , $I_{OUT} = 200\text{ mA}$
		—	3.0	150		$20\text{ V} \leq V_{IN} \leq 30\text{ V}$ , $I_{OUT} = 200\text{ mA}$
Load regulation	$\delta V_{O\text{Load}}$	—	25	300	mV	$T_j = 25^\circ\text{C}$ $5\text{ mA} \leq I_{OUT} \leq 500\text{ mA}$
		—	10	150		$5\text{ mA} \leq I_{OUT} \leq 200\text{ mA}$
Quiescent current	$I_Q$	—	4.8	6.0	mA	$T_j = 25^\circ\text{C}$ , $I_{OUT} = 0$
Quiescent current change	$\delta I_Q$	—	—	0.8	mA	$17.5\text{ V} \leq V_{IN} \leq 30\text{ V}$ , $I_{OUT} = 200\text{ mA}$
		—	—	0.5		$5\text{ mA} \leq I_{OUT} \leq 350\text{ mA}$
Output noise voltage	$V_n$	—	90	—	$\mu\text{V}$	$T_a = 25^\circ\text{C}$ , $10\text{ Hz} \leq f \leq 100\text{ kHz}$
Ripple rejection ratio	$R_{REJ}$	—	70	—	dB	$f = 120\text{ Hz}$ $I_{OUT} = 100\text{ mA}$
		—	70	—		$T_j = 25^\circ\text{C}$ $I_{OUT} = 300\text{ mA}$
Dropout voltage	$V_{drop}$	—	2.0	—	V	$I_{OUT} = 350\text{ mA}$ , $T_j = 25^\circ\text{C}$
Output short-circuit current	$I_{OS}$	—	240	—	mA	$T_j = 25^\circ\text{C}$ , $V_{IN} = 35\text{ V}$
Peak output current	$I_{o\text{ peak}}$	—	700	—	mA	$T_j = 25^\circ\text{C}$
Temperature coefficient of output voltage	$\delta V_{OUT}/\delta T_j$	—	-1.0	—	mV/°C	$I_{OUT} = 5\text{ mA}$ , $0^\circ\text{C} \leq T_j \leq 125^\circ\text{C}$

**HA178M18P/PJ, HA178M18 Electrical Characteristics** ( $V_{IN} = 27\text{ V}$ ,  $I_{OUT} = 350\text{ mA}$ ,  $0^\circ\text{C} \leq T_j \leq 125^\circ\text{C}$ ,  $C_{IN} = 0.33\text{ }\mu\text{F}$ ,  $C_{OUT} = 0.1\text{ }\mu\text{F}$ , unless otherwise specified)

Item	Symbol	Min	Typ	Max	Unit	Test Conditions
Output voltage	$V_{OUT}$	17.3	18.0	18.7	V	$T_j = 25^\circ\text{C}$
		17.1	—	18.9		$21\text{ V} \leq V_{IN} \leq 33\text{ V}$ , $5\text{ mA} \leq I_{OUT} \leq 350\text{ mA}$ , $P_T \leq 7.5\text{ W}$
Line regulation	$dV_{O\text{Line}}$	—	15	360	mV	$T_j = 25^\circ\text{C}$ $21\text{ V} \leq V_{IN} \leq 33\text{ V}$ , $I_{OUT} = 200\text{ mA}$
		—	5.0	180		$24\text{ V} \leq V_{IN} \leq 33\text{ V}$ , $I_{OUT} = 200\text{ mA}$
Load regulation	$\delta V_{O\text{Load}}$	—	25	360	mV	$T_j = 25^\circ\text{C}$ $5\text{ mA} \leq I_{OUT} \leq 500\text{ mA}$
		—	10	180		$5\text{ mA} \leq I_{OUT} \leq 200\text{ mA}$
Quiescent current	$I_Q$	—	4.8	6.0	mA	$T_j = 25^\circ\text{C}$ , $I_{OUT} = 0$
Quiescent current change	$\delta I_Q$	—	—	0.8	mA	$21\text{ V} \leq V_{IN} \leq 35\text{ V}$ , $I_{OUT} = 200\text{ mA}$
		—	—	0.5		$5\text{ mA} \leq I_{OUT} \leq 350\text{ mA}$
Output noise voltage	$V_n$	—	110	—	$\mu\text{V}$	$T_a = 25^\circ\text{C}$ , $10\text{ Hz} \leq f \leq 100\text{ kHz}$
Ripple rejection ratio	$R_{REJ}$	—	70	—	dB	$f = 120\text{ Hz}$ $I_{OUT} = 100\text{ mA}$
		—	70	—		$T_j = 25^\circ\text{C}$ $I_{OUT} = 300\text{ mA}$
Dropout voltage	$V_{drop}$	—	2.0	—	V	$I_{OUT} = 350\text{ mA}$ , $T_j = 25^\circ\text{C}$
Output short-circuit current	$I_{OS}$	—	240	—	mA	$T_j = 25^\circ\text{C}$ , $V_{IN} = 35\text{ V}$
Peak output current	$I_{o\text{ peak}}$	—	700	—	mA	$T_j = 25^\circ\text{C}$
Temperature coefficient of output voltage	$\delta V_{OUT}/\delta T_j$	—	-1.0	—	mV/°C	$I_{OUT} = 5\text{ mA}$ , $0^\circ\text{C} \leq T_j \leq 125^\circ\text{C}$

# HA178M00 Series

**HA178M20P/PJ, HA178M20 Electrical Characteristics** ( $V_{IN} = 29\text{ V}$ ,  $I_{OUT} = 350\text{ mA}$ ,  $0^\circ\text{C} \leq T_j \leq 125^\circ\text{C}$ ,  $C_{IN} = 0.33\text{ }\mu\text{F}$ ,  $C_{OUT} = 0.1\text{ }\mu\text{F}$ , unless otherwise specified)

Item	Symbol	Min	Typ	Max	Unit	Test Conditions
Output voltage	$V_{OUT}$	19.2	20	20.8	V	$T_j = 25^\circ\text{C}$
		19	—	21		$23\text{ V} \leq V_{IN} \leq 35\text{ V}$ , $5\text{ mA} \leq I_{OUT} \leq 350\text{ mA}$ , $P_T \leq 7.5\text{ W}$
Line regulation	$\delta V_{O\text{Line}}$	—	17	400	mV	$T_j = 25^\circ\text{C}$ $23\text{ V} \leq V_{IN} \leq 35\text{ V}$ , $I_{OUT} = 200\text{ mA}$
		—	6.0	200		$24\text{ V} \leq V_{IN} \leq 35\text{ V}$ , $I_{OUT} = 200\text{ mA}$
Load regulation	$\delta V_{O\text{Load}}$	—	30	400	mV	$T_j = 25^\circ\text{C}$ $5\text{ mA} \leq I_{OUT} \leq 500\text{ mA}$
		—	10	200		$5\text{ mA} \leq I_{OUT} \leq 200\text{ mA}$
Quiescent current	$I_Q$	—	4.9	6.0	mA	$T_j = 25^\circ\text{C}$ , $I_{OUT} = 0$
Quiescent current change	$\delta I_Q$	—	—	0.8	mA	$23\text{ V} \leq V_{IN} \leq 35\text{ V}$ , $I_{OUT} = 200\text{ mA}$
		—	—	0.5		$5\text{ mA} \leq I_{OUT} \leq 350\text{ mA}$
Output noise voltage	$V_n$	—	110	—	$\mu\text{V}$	$T_a = 25^\circ\text{C}$ , $10\text{ Hz} \leq f \leq 100\text{ kHz}$
Ripple rejection ratio	$R_{REJ}$	—	70	—	dB	$f = 120\text{ Hz}$ $I_{OUT} = 100\text{ mA}$
		—	70	—		$T_j = 25^\circ\text{C}$ $I_{OUT} = 300\text{ mA}$
Dropout voltage	$V_{drop}$	—	2.0	—	V	$I_{OUT} = 350\text{ mA}$ , $T_j = 25^\circ\text{C}$
Output short-circuit current	$I_{OS}$	—	240	—	mA	$T_j = 25^\circ\text{C}$ , $V_{IN} = 35\text{ V}$
Peak output current	$I_{o\text{ peak}}$	—	700	—	mA	$T_j = 25^\circ\text{C}$
Temperature coefficient of output voltage	$\delta V_{OUT}/\delta T_j$	—	-1.1	—	mV/°C	$I_{OUT} = 5\text{ mA}$ , $0^\circ\text{C} \leq T_j \leq 125^\circ\text{C}$

**HA178M24P/PJ, HA178M24 Electrical Characteristics** ( $V_{IN} = 33\text{ V}$ ,  $I_{OUT} = 350\text{ mA}$ ,  $0^\circ\text{C} \leq T_j \leq 125^\circ\text{C}$ ,  $C_{IN} = 0.33\text{ }\mu\text{F}$ ,  $C_{OUT} = 0.1\text{ }\mu\text{F}$ , unless otherwise specified)

Item	Symbol	Min	Typ	Max	Unit	Test Conditions
Output voltage	$V_{OUT}$	23.0	24.0	25.0	V	$T_j = 25^\circ\text{C}$
		22.8	—	25.2		$27\text{ V} \leq V_{IN} \leq 38\text{ V}$ , $5\text{ mA} \leq I_{OUT} \leq 350\text{ mA}$ , $P_T \leq 7.5\text{ W}$
Line regulation	$\delta V_{O\text{Line}}$	—	18	480	mV	$T_j = 25^\circ\text{C}$ $27\text{ V} \leq V_{IN} \leq 38\text{ V}$ , $I_{OUT} = 200\text{ mA}$
		—	6.0	240		$28\text{ V} \leq V_{IN} \leq 38\text{ V}$ , $I_{OUT} = 200\text{ mA}$
Load regulation	$\delta V_{O\text{Load}}$	—	30	480	mV	$T_j = 25^\circ\text{C}$ $5\text{ mA} \leq I_{OUT} \leq 500\text{ mA}$
		—	10	240		$5\text{ mA} \leq I_{OUT} \leq 200\text{ mA}$
Quiescent current	$I_Q$	—	5.0	8.0	mA	$T_j = 25^\circ\text{C}$ , $I_{OUT} = 0$
Quiescent current change	$\delta I_Q$	—	—	0.8	mA	$27\text{ V} \leq V_{IN} \leq 38\text{ V}$ , $I_{OUT} = 200\text{ mA}$
		—	—	0.5		$5\text{ mA} \leq I_{OUT} \leq 350\text{ mA}$
Output noise voltage	$V_n$	—	170	—	$\mu\text{V}$	$T_a = 25^\circ\text{C}$ , $10\text{ Hz} \leq f \leq 100\text{ kHz}$
Ripple rejection ratio	$R_{REJ}$	—	70	—	dB	$f = 120\text{ Hz}$ $I_{OUT} = 100\text{ mA}$
		—	70	—		$T_j = 25^\circ\text{C}$ $I_{OUT} = 300\text{ mA}$
Dropout voltage	$V_{drop}$	—	2.0	—	V	$I_{OUT} = 350\text{ mA}$ , $T_j = 25^\circ\text{C}$
Output short-circuit current	$I_{OS}$	—	240	—	mA	$T_j = 25^\circ\text{C}$ , $V_{IN} = 35\text{ V}$
Peak output current	$I_o\text{ peak}$	—	700	—	mA	$T_j = 25^\circ\text{C}$
Temperature coefficient of output voltage	$\delta V_{OUT}/\delta T_j$	—	-1.2	—	$\text{mV}/^\circ\text{C}$	$I_{OUT} = 5\text{ mA}$ , $0^\circ\text{C} \leq T_j \leq 125^\circ\text{C}$

## Characteristic Curves

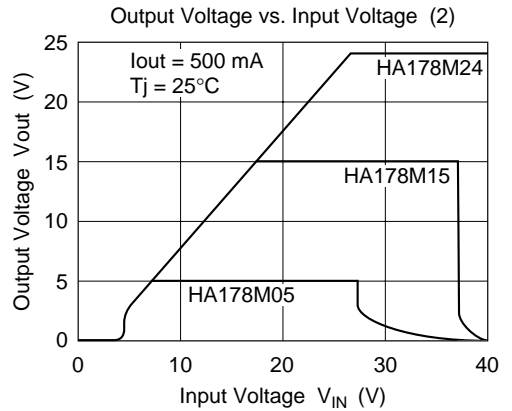
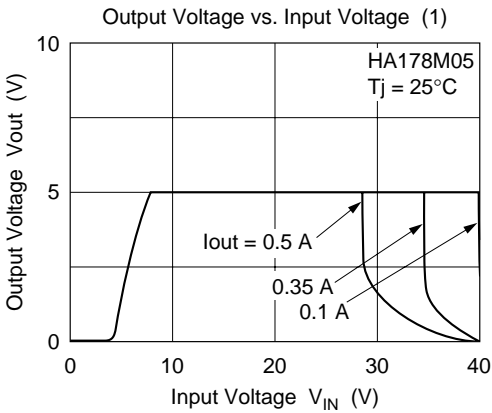
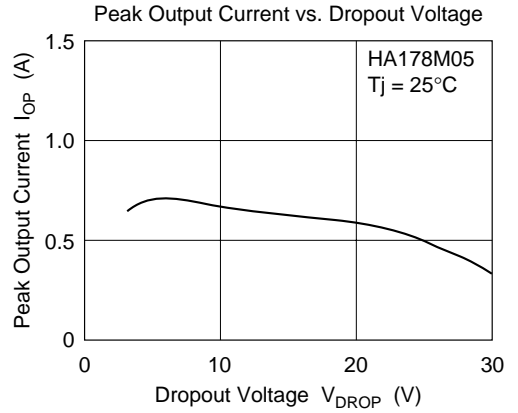
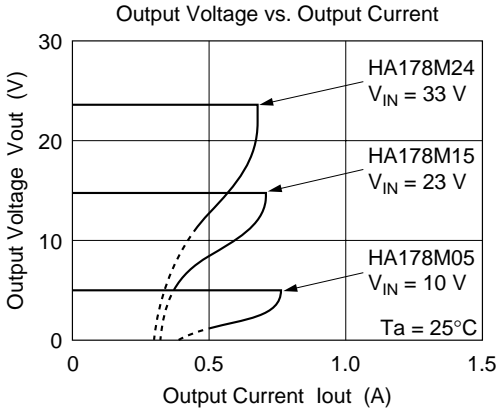
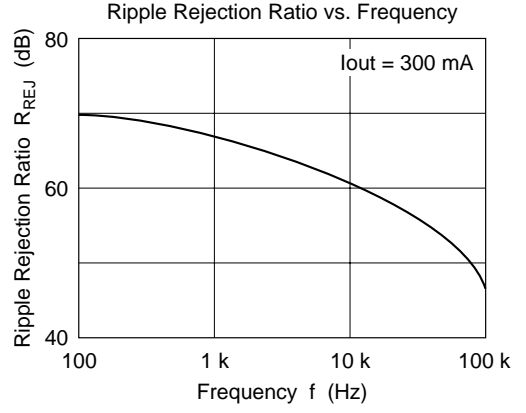
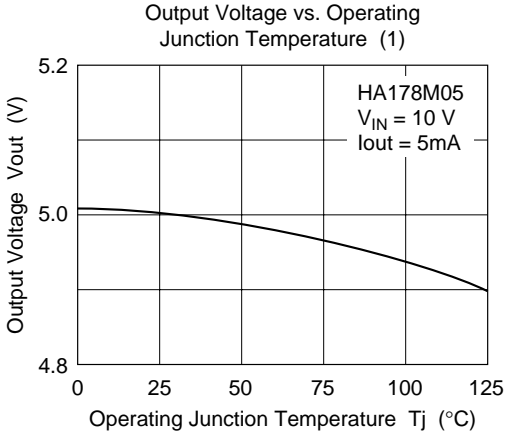

Quiescent Operating Current vs. Input Voltage

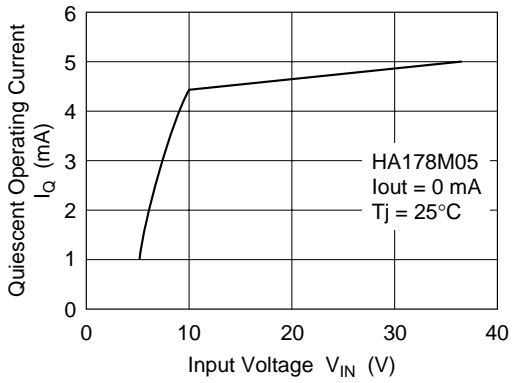

Output Voltage vs. Operating Junction Temperature (2)

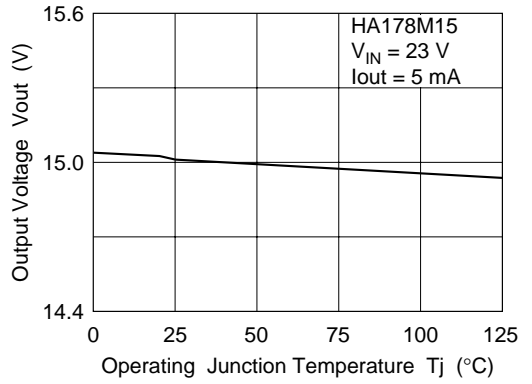

Output Voltage vs. Operating Junction Temperature (3)

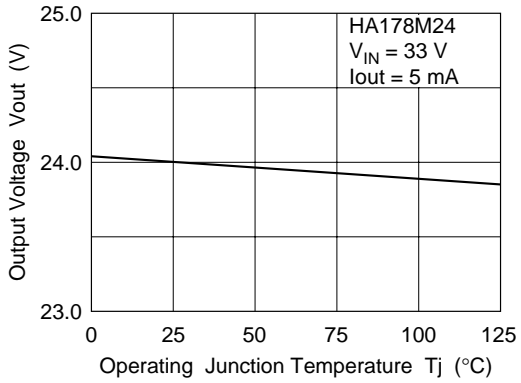

## Package Dimensions

Unit: mm

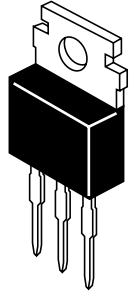
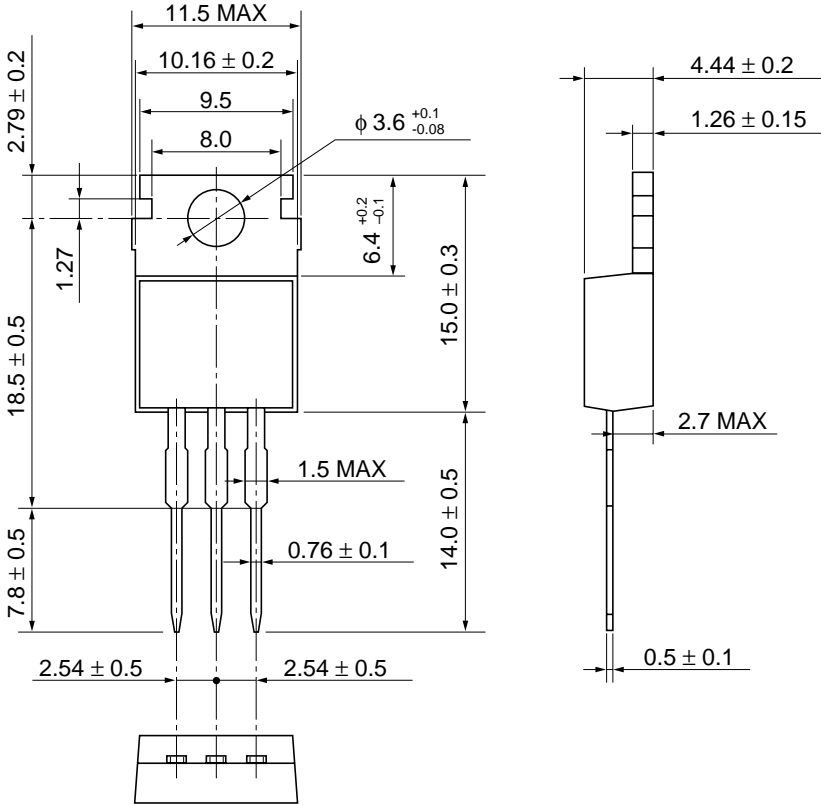

Hitachi Code	TO-220AB
JEDEC	Conforms
EIAJ	Conforms
Mass (reference value)	1.8 g

## Cautions

1. Hitachi neither warrants nor grants licenses of any rights of Hitachi's or any third party's patent, copyright, trademark, or other intellectual property rights for information contained in this document. Hitachi bears no responsibility for problems that may arise with third party's rights, including intellectual property rights, in connection with use of the information contained in this document.
2. Products and product specifications may be subject to change without notice. Confirm that you have received the latest product standards or specifications before final design, purchase or use.
3. Hitachi makes every attempt to ensure that its products are of high quality and reliability. However, contact Hitachi's sales office before using the product in an application that demands especially high quality and reliability or where its failure or malfunction may directly threaten human life or cause risk of bodily injury, such as aerospace, aeronautics, nuclear power, combustion control, transportation, traffic, safety equipment or medical equipment for life support.
4. Design your application so that the product is used within the ranges guaranteed by Hitachi particularly for maximum rating, operating supply voltage range, heat radiation characteristics, installation conditions and other characteristics. Hitachi bears no responsibility for failure or damage when used beyond the guaranteed ranges. Even within the guaranteed ranges, consider normally foreseeable failure rates or failure modes in semiconductor devices and employ systemic measures such as fail-safes, so that the equipment incorporating Hitachi product does not cause bodily injury, fire or other consequential damage due to operation of the Hitachi product.
5. This product is not designed to be radiation resistant.
6. No one is permitted to reproduce or duplicate, in any form, the whole or part of this document without written approval from Hitachi.
7. Contact Hitachi's sales office for any questions regarding this document or Hitachi semiconductor products.

# HITACHI

## Hitachi, Ltd.

Semiconductor & Integrated Circuits.

Nippon Bldg., 2-6-2, Ohite-machi, Chiyoda-ku, Tokyo 100-0004, Japan

Tel: Tokyo (03) 3270-2111 Fax: (03) 3270-5109

URL      NorthAmerica      : <http://semiconductor.hitachi.com/>  
 Europe                    : <http://www.hitachi-eu.com/hel/ecg>  
 Asia (Singapore)        : <http://www.has.hitachi.com.sg/grp3/sicd/index.htm>  
 Asia (Taiwan)            : [http://www.hitachi.com.tw/E/Product/SICD\\_Frame.htm](http://www.hitachi.com.tw/E/Product/SICD_Frame.htm)  
 Asia (HongKong)        : <http://www.hitachi.com.hk/eng/bo/grp3/index.htm>  
 Japan                      : <http://www.hitachi.co.jp/Sicd/indx.htm>

## For further information write to:

Hitachi Semiconductor  
 (America) Inc.  
 179 East Tasman Drive,  
 San Jose, CA 95134  
 Tel: <1> (408) 433-1990  
 Fax: <1> (408) 433-0223

Hitachi Europe GmbH  
 Electronic components Group  
 Dornacher Straße 3  
 D-85622 Feldkirchen, Munich  
 Germany  
 Tel: <49> (89) 9 9180-0  
 Fax: <49> (89) 9 29 30 00

Hitachi Europe Ltd.  
 Electronic Components Group.  
 Whitebrook Park  
 Lower Cookham Road  
 Maidenhead  
 Berkshire SL6 8YA, United Kingdom  
 Tel: <44> (1628) 585000  
 Fax: <44> (1628) 778322

Hitachi Asia Pte. Ltd.  
 16 Collyer Quay #20-00  
 Hitachi Tower  
 Singapore 049318  
 Tel: 535-2100  
 Fax: 535-1533

Hitachi Asia Ltd.  
 Taipei Branch Office  
 3F, Hung Kuo Building, No.167,  
 Tun-Hwa North Road, Taipei (105)  
 Tel: <886> (2) 2718-3666  
 Fax: <886> (2) 2718-8180

Hitachi Asia (Hong Kong) Ltd.  
 Group III (Electronic Components)  
 7/F., North Tower, World Finance Centre,  
 Harbour City, Canton Road, Tsim Sha Tsui,  
 Kowloon, Hong Kong  
 Tel: <852> (2) 735 9218  
 Fax: <852> (2) 730 0281  
 Telex: 40815 HITEC HX

Copyright ' Hitachi, Ltd., 1998. All rights reserved. Printed in Japan.

## HITACHI

This datasheet has been downloaded from:

[www.DatasheetCatalog.com](http://www.DatasheetCatalog.com)

Datasheets for electronic components.



LittleDiode supplies new, hard to find or obsolete electronic components and semiconductors all over the world.

With over two million different components listed you are sure to find the part you need.

Feel free to visit us today at our online store:

[LittleDiode.com](http://LittleDiode.com)

Looking forward to providing you with the best possible service.