

# GP2L22

## Subminiature, High Sensitivity Photointerrupter

### ■ Features

1.  $\phi$  4mm compact resin mold type
2. High sensitivity ( $I_C$ : MIN. 0.5mA at  $I_F = 4mA$ )
3. Optimum detection distance: 0.6mm
4. Visible light cut-off type

### ■ Applications

1. Audio equipment, VCRs

### ■ Outline Dimensions

(Unit : mm)

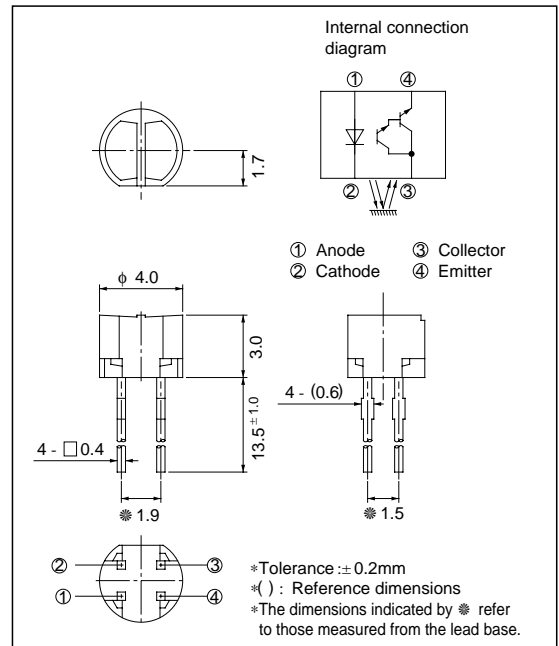

### ■ Absolute Maximum Ratings

(Ta = 25°C)

Parameter		Symbol	Rating	Unit
Input	Forward current	$I_F$	50	mA
	Reverse voltage	$V_R$	6	V
	Power dissipation	$P$	75	mW
Output	Collector-emitter voltage	$V_{CEO}$	35	V
	Emitter-collector voltage	$V_{ECO}$	6	V
	Collector current	$I_C$	50	mA
	Collector power dissipation	$P_C$	75	mW
Total power dissipation		$P_{tot}$	100	mW
Operating temperature		$T_{opr}$	- 25 to + 85	°C
Storage temperature		$T_{sg}$	- 40 to + 100	°C
*1 Soldering temperature		$T_{sol}$	260	°C

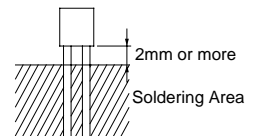

\*1 For 3 seconds by manual soldering

**Electro-optical Characteristics**

( $T_a = 25^\circ\text{C}$ )

Parameter		Symbol	Conditions	MIN.	TYP.	MAX.	Unit	
Input	Forward voltage	$V_F$	$I_F = 20\text{mA}$	-	1.2	1.4	V	
	Reverse current	$I_R$	$V_R = 6\text{V}$	-	-	10	$\mu\text{A}$	
Output	Collector dark current	$I_{CEO}$	$V_{CE} = 10\text{V}$	-	-	$10^{-6}$	A	
Transfer characteristics	<sup>*2</sup> Collector current		$I_C$	$V_{CE} = 5\text{V}, I_F = 4\text{mA}$	0.5	-	15	mA
	Response time	Rise time	$t_r$	$V_{CE} = 2\text{V}, I_C = 10\text{mA}$	-	80	400	$\mu\text{s}$
		Fall time	$t_f$	$R_L = 100\ \Omega, d = 1\text{mm}$	-	70	400	$\mu\text{s}$
	<sup>*3</sup> Leak current		$I_{LEAK}$	$V_{CE} = 5\text{V}, I_F = 4\text{mA}$	-	-	5	$\mu\text{A}$

\*2 The condition and arrangement of the reflective object are shown in the right drawing.

\*3 Without reflective object

The ranking of collector current shall be classified into the following 5 ranks.

Rank	$I_C$ (mA)
A	4.0 to 15.0
B	1.45 to 5.4
A or B	1.45 to 15.0
B or C	0.5 to 5.4
A, B or C	0.5 to 15.0

**Test Condition and Arrangement for Collector Current**

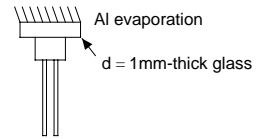

**Fig. 1 Forward Current vs. Ambient Temperature**

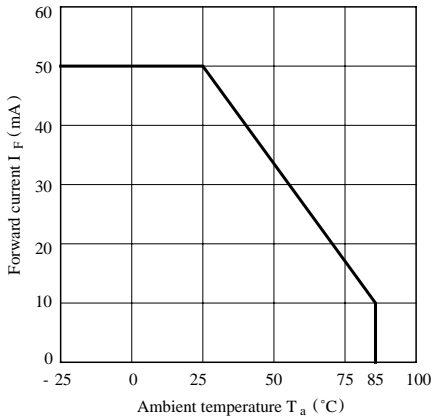

**Fig. 2 Power Dissipation vs. Ambient Temperature**

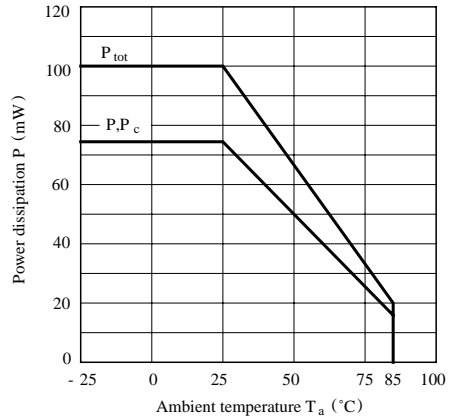

**Fig. 3 Forward Current vs. Forward Voltage**

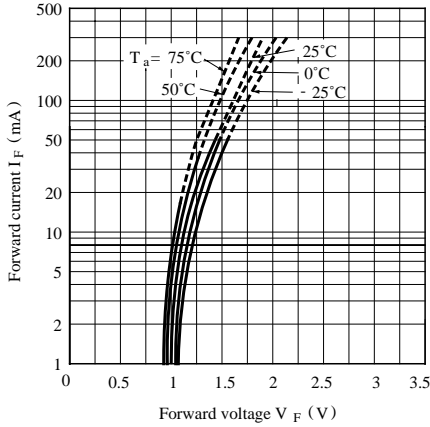

**Fig. 4 Collector Current vs. Forward Current**

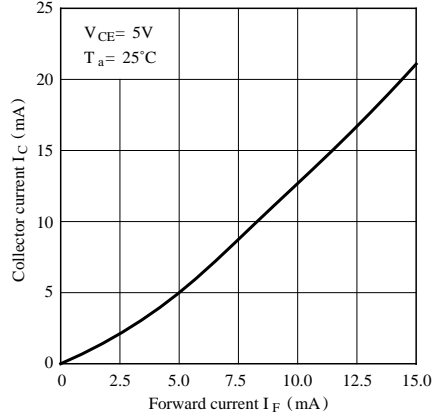

**Fig. 5 Collector Current vs. Collector-emitter Voltage**

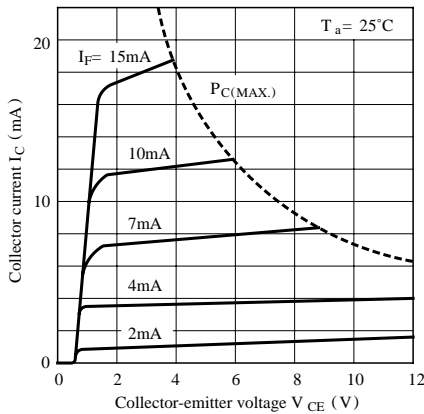

**Fig. 6 Collector Current vs. Ambient Temperature**

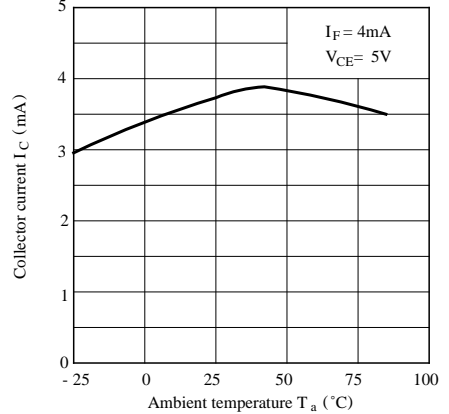

**Fig. 7 Collector Dark Current vs. Ambient Temperature**

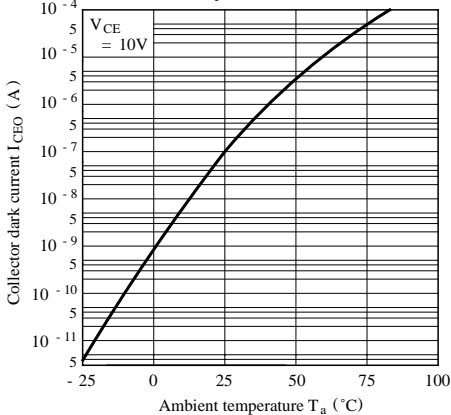

**Fig. 8 Response Time vs. Load Resistance**

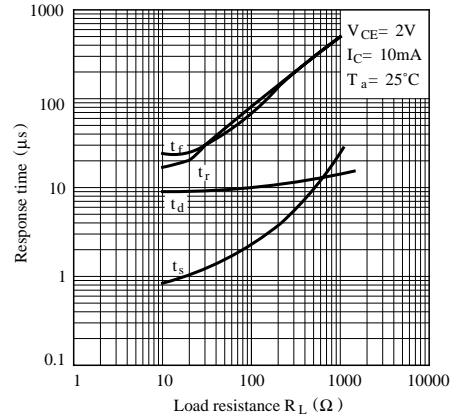

Test Circuit for Response time

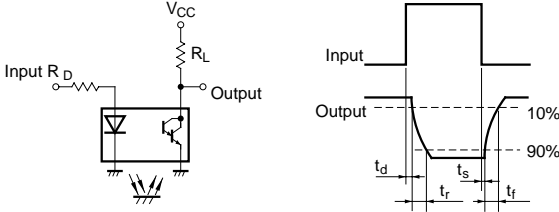

Fig.9 Relative Collector Current vs. Distance between Sensor and Test Card

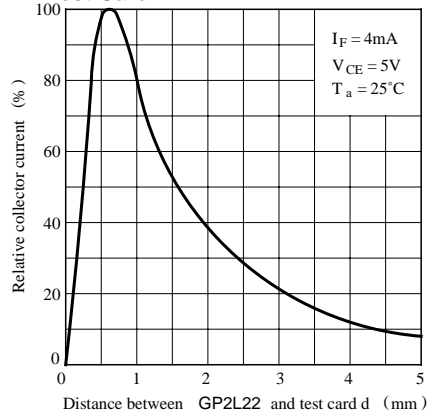
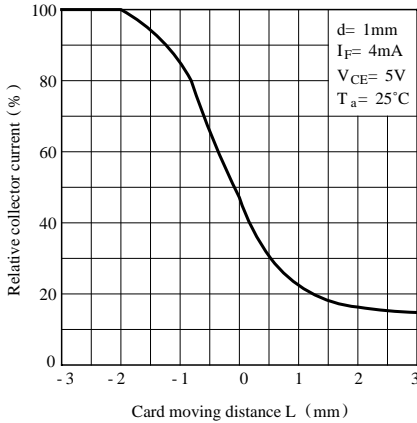

Fig.10 Relative Collector Current vs. Card Moving Distance



Test Condition for Distance & Detecting Position Characteristics

Correspond to Fig.9



Correspond to Fig.10

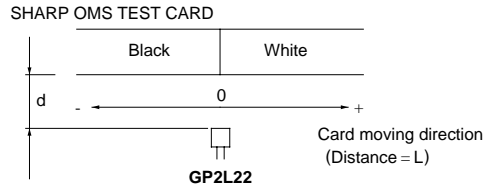

■ Precautions for Use

- (1) Perform soldering manually.
- (2) Please refrain from soldering under preheating and refrain from soldering by reflow.
- (3) As for other general cautions, refer to the chapter “Precautions for Use”.



LittleDiode supplies new, hard to find or obsolete electronic components and semiconductors all over the world.

With over two million different components listed you are sure to find the part you need.

Feel free to visit us today at our online store:

[LittleDiode.com](http://LittleDiode.com)

Looking forward to providing you with the best possible service.