

# GP1S23

## Subminiature Photointerrupter

### ■ Features

1. Ultra-compact
2. PWB mounting type package
3. High sensing accuracy (Slit width: 0.3mm)
4. Gap between light emitter and detector: 2mm

### ■ Applications

1. Cameras
2. Floppy disk drives

### ■ Outline Dimensions

(Unit : mm)

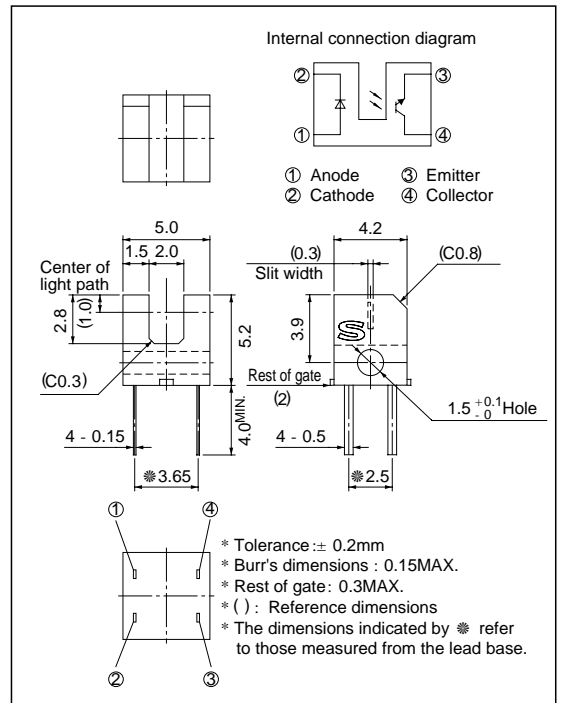

### ■ Absolute Maximum Ratings

(Ta = 25°C)

Parameter		Symbol	Rating	Unit
Input	Forward current	I <sub>F</sub>	50	mA
	Reverse voltage	V <sub>R</sub>	6	V
	Power dissipation	P	75	mW
Output	Collector-emitter voltage	V <sub>CEO</sub>	35	V
	Emitter-collector voltage	V <sub>ECO</sub>	6	V
	Collector current	I <sub>C</sub>	20	mA
	Collector power dissipation	P <sub>C</sub>	75	mW
Total power dissipation		P <sub>tot</sub>	100	mW
Operating temperature		T <sub>opr</sub>	- 25 to + 85	°C
Storage temperature		T <sub>stg</sub>	- 40 to + 100	°C
*1 Soldering temperature		T <sub>sol</sub>	260	°C

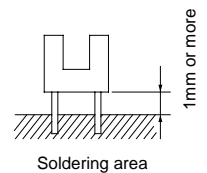

\*1 For 3 seconds

**Electro-optical Characteristics**

( $T_a = 25^\circ\text{C}$ )

Parameter		Symbol	Conditions	MIN.	TYP.	MAX.	Unit
Input	Forward voltage	$V_F$	$I_F = 20\text{mA}$	-	1.2	1.4	V
	Reverse current	$I_R$	$V_R = 3\text{V}$	-	-	10	$\mu\text{A}$
Output	Collector dark current	$I_{CEO}$	$V_{CE} = 20\text{V}$	-	-	$1 \times 10^{-7}$	A
Transfer-characteristics	Collector Current	$I_C$	$I_F = 5\text{mA}, V_{CE} = 5\text{V}$	40	-	400	$\mu\text{A}$
	Collector-emitter saturation voltage	$V_{CE(sat)}$	$I_F = 10\text{mA}, I_C = 40\mu\text{A}$	-	-	0.4	V
	Response time	Rise time	$t_r$	$I_C = 0.1\text{mA}, V_{CE} = 5\text{V}, R_L = 1\text{k}\Omega$	-	50	150
Fall time		$t_f$	-		50	150	$\mu\text{s}$

**Fig. 1 Forward Current vs. Ambient Temperature**

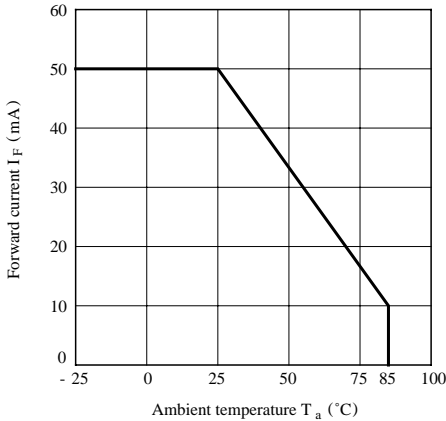

**Fig. 2 Power Dissipation vs. Ambient Temperature**

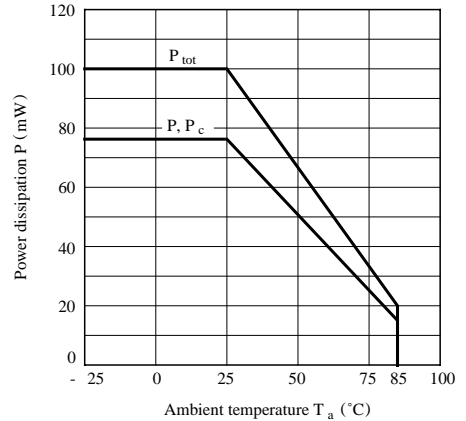

**Fig. 3 Forward Current vs. Forward Voltage**

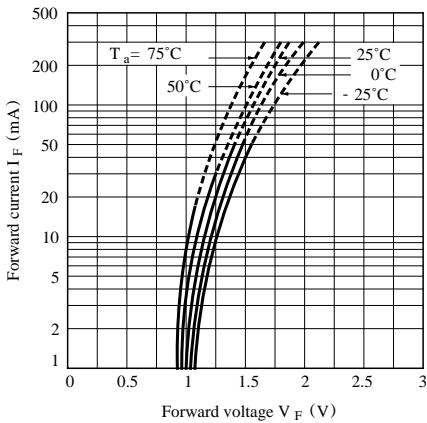

**Fig. 4 Collector Current vs. Forward Current**

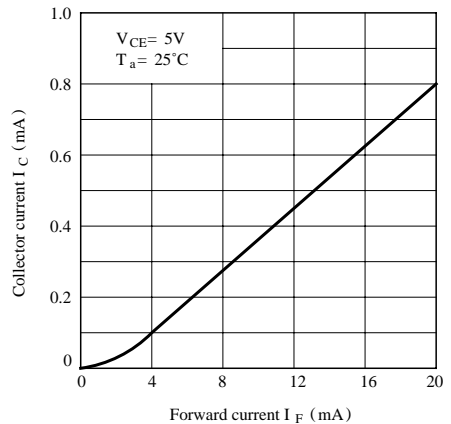

**Fig. 5 Collector Current vs. Collector-emitter voltage**

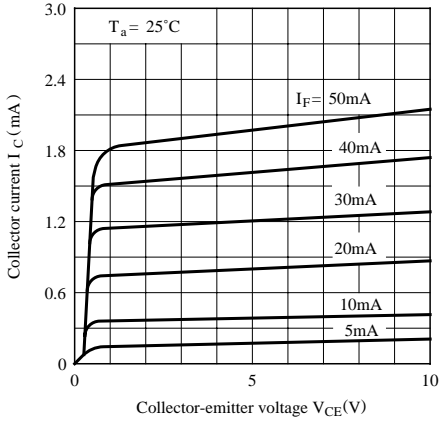

**Fig. 6 Collector Current vs. Ambient Temperature**

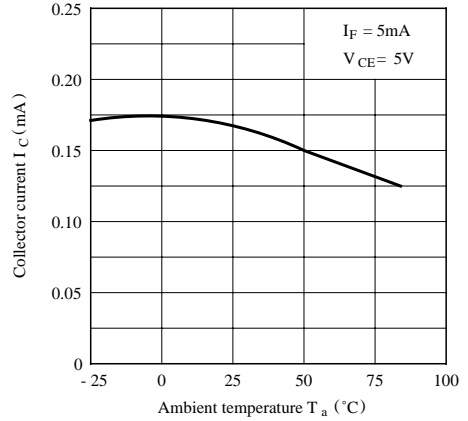

**Fig. 7 Collector-emitter Saturation Voltage vs. Ambient Temperature**

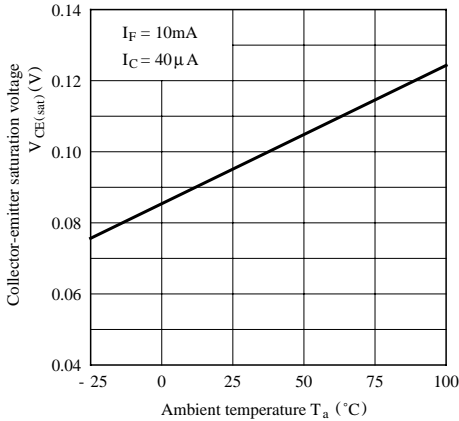

**Fig. 8 Collector Dark Current vs. Ambient Temperature**

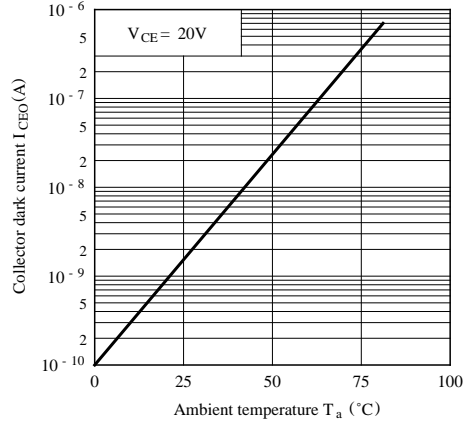

**Fig. 9 Response Time vs. Load Resistance**

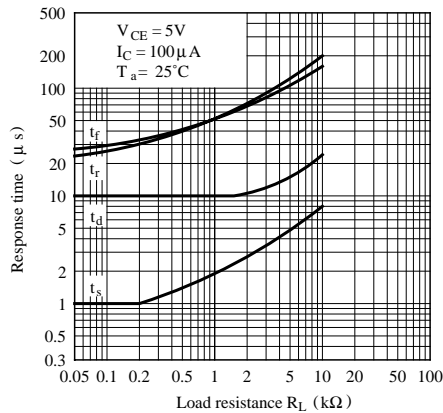

**Test Circuit for Response Time**

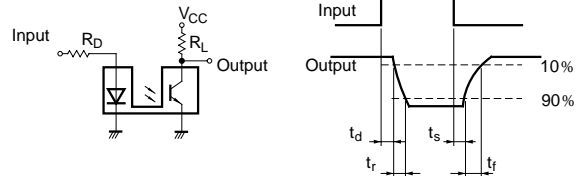

**Fig.10 Relative Collector Current vs. Shield Distance (1)**

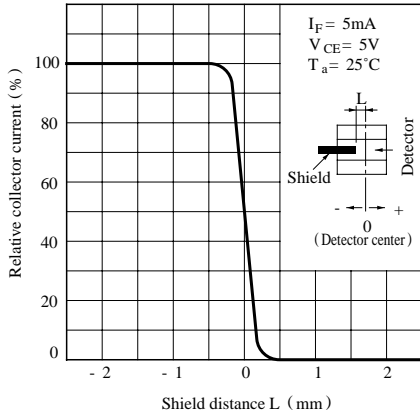

**Fig.11 Relative Collector Current vs. Shield Distance (2)**

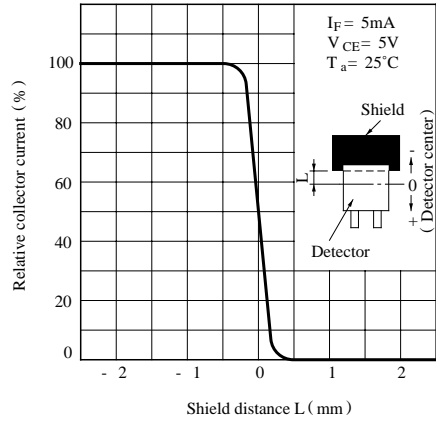

- Please refer to the chapter “Precautions for Use”.



LittleDiode supplies new, hard to find or obsolete electronic components and semiconductors all over the world.

With over two million different components listed you are sure to find the part you need.

Feel free to visit us today at our online store:

[LittleDiode.com](http://LittleDiode.com)

Looking forward to providing you with the best possible service.