

# GP1S06

## High Sensing Accuracy Type Photointerrupter

### ■ Features

1. High sensing accuracy  
(Slit width : 0.25mm)
2. PWB direct mounting type package

### ■ Applications

1. Floppy disk drives
2. Copiers, printers, facsimiles
3. Optoelectronic switches, optoelectronic counters

### ■ Outline Dimensions

(Unit : mm)

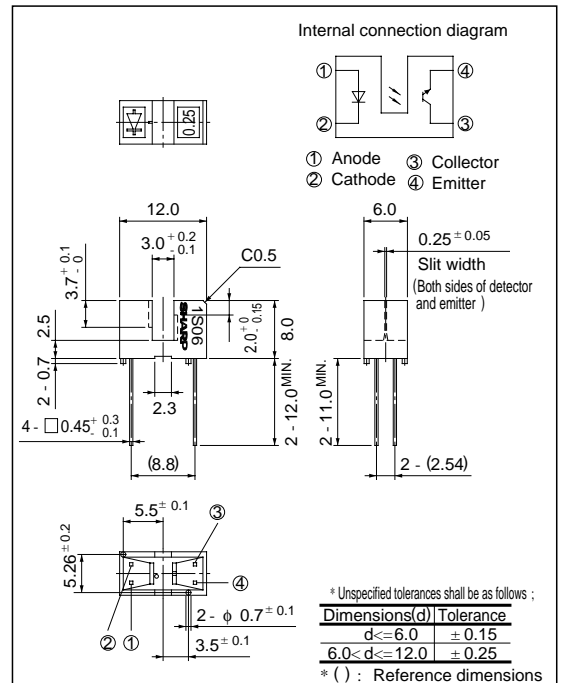

### ■ Absolute Maximum Ratings

(Ta = 25°C)

Parameter		Symbol	Rating	Unit
Input	Forward current	I <sub>F</sub>	50	mA
	*1 Peak forward current	I <sub>FM</sub>	1	A
	Reverse voltage	V <sub>R</sub>	6	V
	Power dissipation	P	75	mW
Output	Collector-emitter voltage	V <sub>CEO</sub>	35	V
	Emitter-collector voltage	V <sub>ECO</sub>	6	V
	Collector current	I <sub>C</sub>	20	mA
	Collector power dissipation	P <sub>C</sub>	75	mW
Operating temperature		T <sub>opr</sub>	- 25 to + 85	°C
Storage temperature		T <sub>stg</sub>	- 40 to + 100	°C
*2 Soldering temperature		T <sub>sol</sub>	260	°C

\*1 Pulse width ≤ 100μs, Duty ratio = 0.01

\*2 For 5 seconds

**■ Electro-optical Characteristics**

( $T_a = 25^\circ\text{C}$ )

Parameter		Symbol	Conditions	MIN.	TYP.	MAX.	Unit	
Input	Forward voltage	$V_F$	$I_F = 20\text{mA}$	-	1.2	1.4	V	
	Peak forward voltage	$V_{FM}$	$I_{FM} = 0.5\text{A}$	-	3	4	V	
	Reverse current	$I_R$	$V_R = 3\text{V}$	-	-	10	$\mu\text{A}$	
Output	Collector dark current	$I_{CEO}$	$V_{CE} = 20\text{V}$	-	1	100	nA	
Transfer characteristics	Collector Current		$I_c$	$V_{CE} = 5\text{V}, I_F = 20\text{mA}$	0.1	-	2.5	mA
	Collector-emitter saturation voltage		$V_{CE(sat)}$	$I_F = 40\text{mA}, I_C = 50\ \mu\text{A}$	-	-	0.4	V
	Response time	Rise time	$t_r$	$V_{CE} = 2\text{V}, I_C = 0.5\text{mA}, R_L = 1\text{k}\Omega$	-	38	90	$\mu\text{s}$
		Fall time	$t_f$		-	48	110	$\mu\text{s}$

**Fig. 1 Forward Current vs. Ambient Temperature**

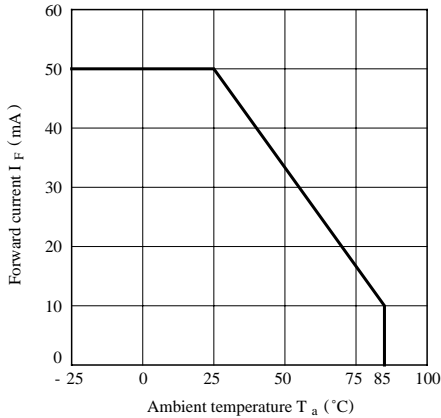

**Fig. 2 Collector Power Dissipation vs. Ambient Temperature**

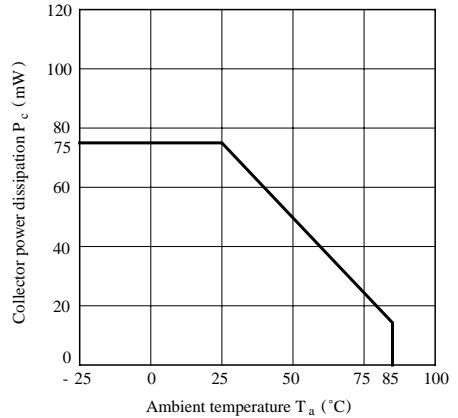

**Fig. 3 Peak Forward Current vs. Duty Ratio**

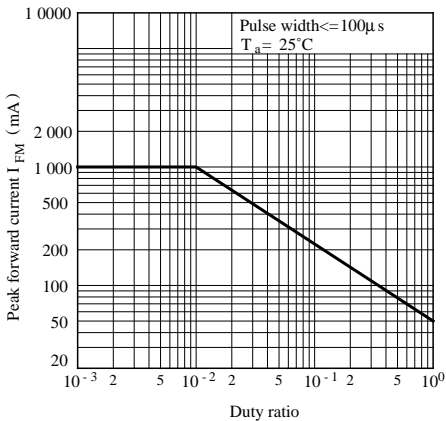

**Fig. 4 Forward Current vs. Forward Voltage**

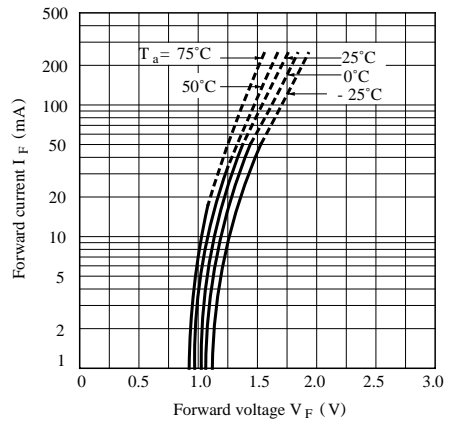

Fig. 5 Collector Current vs. Forward Current

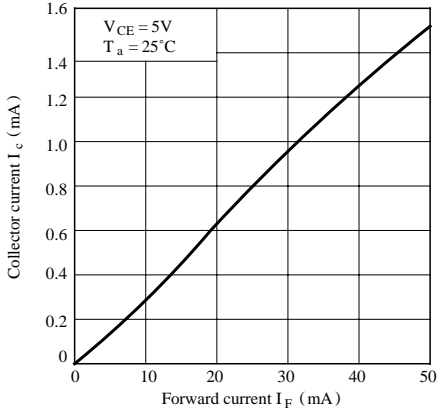

Fig. 6 Collector Current vs. Collector-emitter Voltage

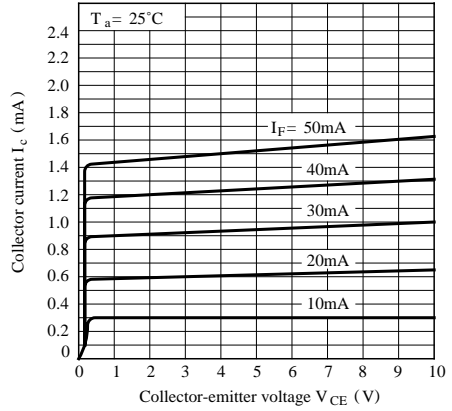

Fig. 7 Collector Current vs. Ambient Temperature

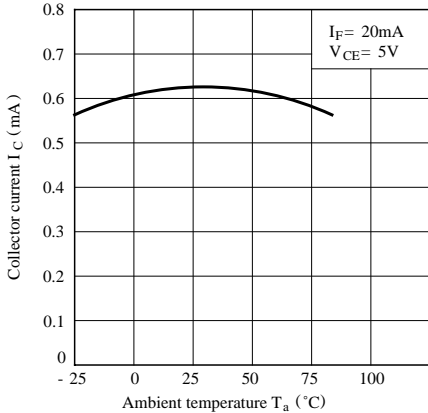

Fig. 8 Collector-emitter Saturation Voltage vs. Ambient Temperature

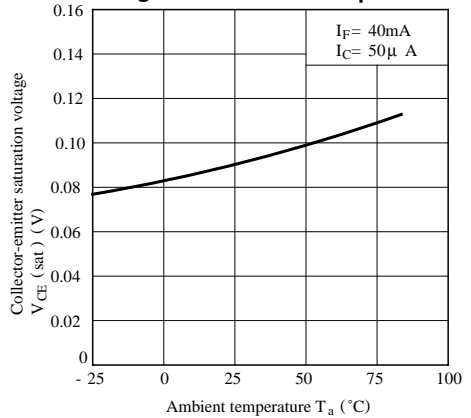
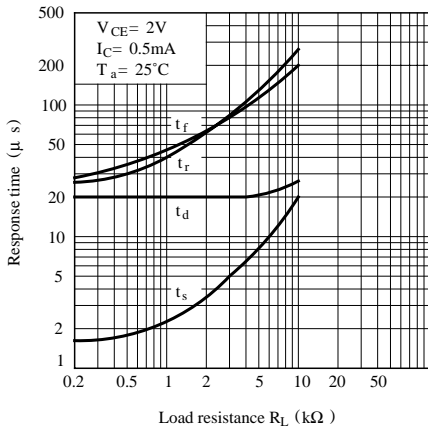

Fig. 9 Response Time vs. Load Resistance



Test Circuit for Response Time

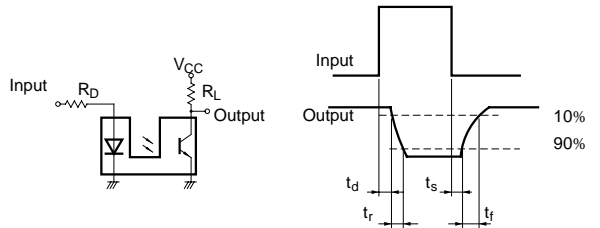

Fig.10 Frequency Response

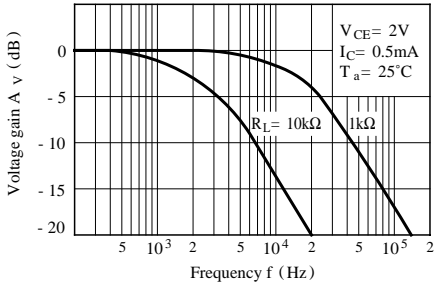

Fig.11 Collector Dark Current vs. Ambient Temperature

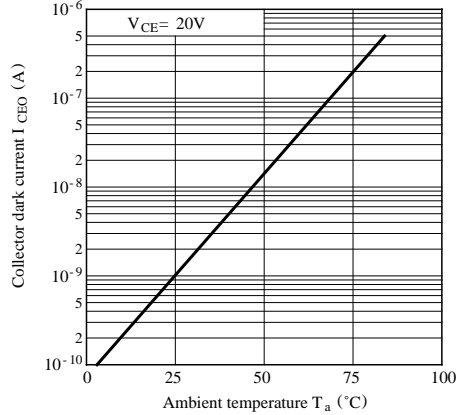

Fig.12 Relative Collector Current vs. Shield Distance (1)

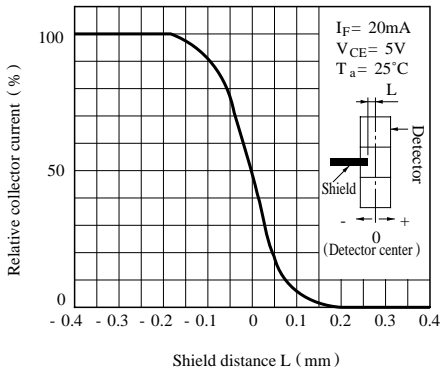
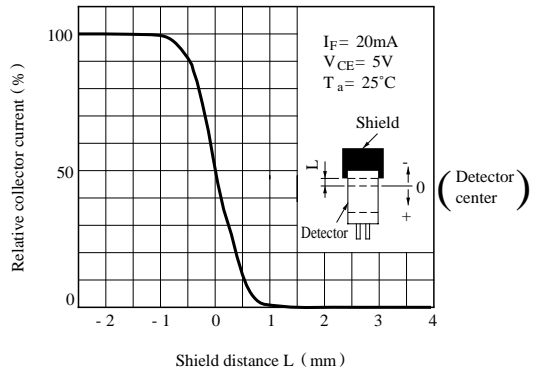

Fig.13 Relative Collector Current vs. Shield Distance (2)



● Please refer to the chapter “Precautions for Use” (Page 78 to 93 ).



LittleDiode supplies new, hard to find or obsolete electronic components and semiconductors all over the world.

With over two million different components listed you are sure to find the part you need.

Feel free to visit us today at our online store:

[LittleDiode.com](http://LittleDiode.com)

Looking forward to providing you with the best possible service.