

GP1L21/GP1L22

Subminiature, High Sensitivity Photointerrupter

■ Features

1. Ultra-compact (Capacity: 0.06cc)
2. High sensing accuracy
(Slit width: 0.3mm **GP1L22**)
3. High current transfer ratio
(CTR: MIN. 40% , **GP1L21**)
(MIN. 20% , **GP1L22**)
4. PWB direct mounting type
5. With mounting hole

■ Applications

1. Cameras
2. Floppy disk drives

■ Outline Dimensions

(Unit : mm)

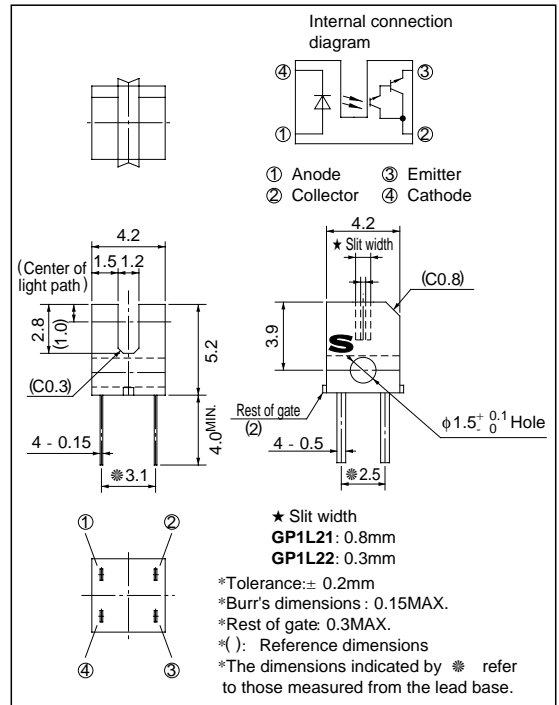

■ Absolute Maximum Ratings

(Ta = 25°C)

	Parameter	Symbol	Rating	Unit
Input	Forward current	I _F	50	mA
	Reverse voltage	V _R	6	V
	Power dissipation	P	75	mW
Output	Collector-emitter voltage	V _{CEO}	35	V
	Emitter-collector voltage	V _{ECO}	6	V
	Collector current	I _C	40	mA
	Collector power dissipation	P _C	75	mW
	Total power dissipation	P _{tot}	100	mW
	Operating temperature	T _{opr}	- 25 to + 85	°C
	Storage temperature	T _{stg}	- 40 to + 100	°C
	*1 Soldering temperature	T _{sol}	260	°C

*1 For 5 seconds

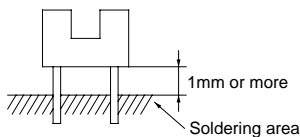

Electro-optical Characteristics

($T_a = 25^\circ\text{C}$)

Parameter		Symbol	Conditions	MIN.	TYP.	MAX.	Unit
Input	Forward voltage	V_F	$I_F = 20\text{mA}$	-	1.2	1.4	V
	Reverse current	I_R	$V_R = 3\text{V}$	-	-	10	μA
Output	Collector dark current	I_{CEO}	$V_{CE} = 10\text{V}$	-	-	10^{-6}	A
Transfer characteristics	Collector Current	GP1L21	$V_{CE} = 2\text{V}, I_F = 1\text{mA}$	0.4	-	15	mA
		GP1L22	$V_{CE} = 2\text{V}, I_F = 1\text{mA}$	0.2	-	7	mA
	Collector-emitter saturation voltage	GP1L21	$I_F = 2\text{mA}, I_C = 0.4\text{mA}$	-	-	1.0	V
		GP1L22	$I_F = 2\text{mA}, I_C = 0.2\text{mA}$	-	-	1.0	V
	Response time	Rise time	t_r	$V_{CE} = 2\text{V}, I_C = 10\text{mA}$	-	80	400
Fall time		t_f	$R_L = 100\Omega$	-	70	350	μs

Fig. 1 Forward Current vs. Ambient Temperature

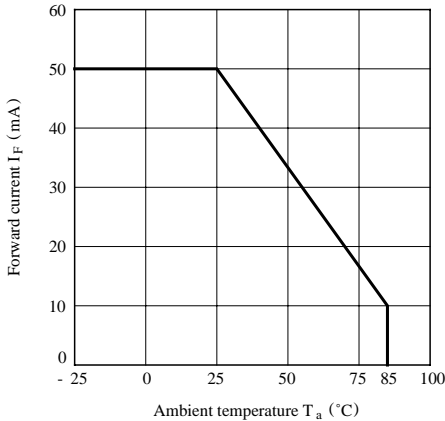

Fig. 2 Power Dissipation vs. Ambient Temperature

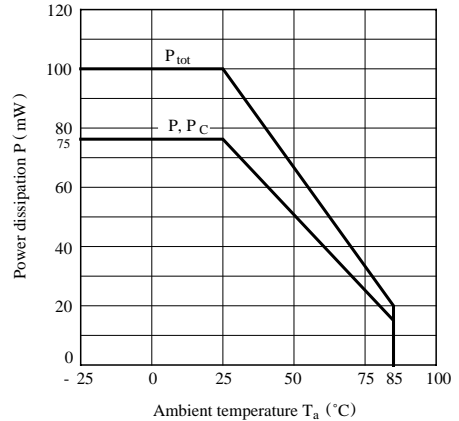

Fig. 3 Forward Current vs. Forward Voltage

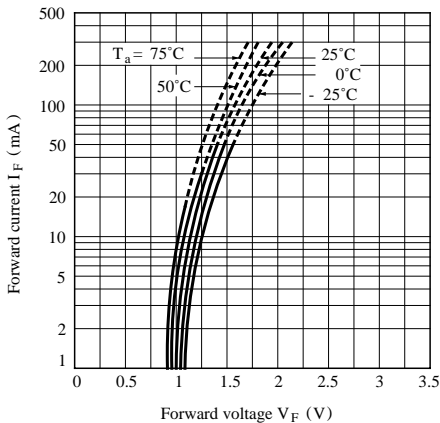

Fig. 4 Collector Current vs. Forward Current

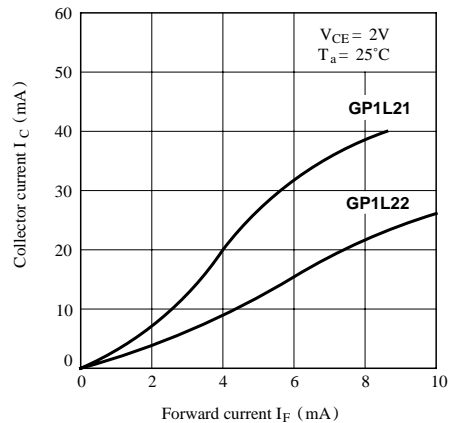

Fig. 5-a Collector Current vs. Collector-emitter Voltage (GP1L21)

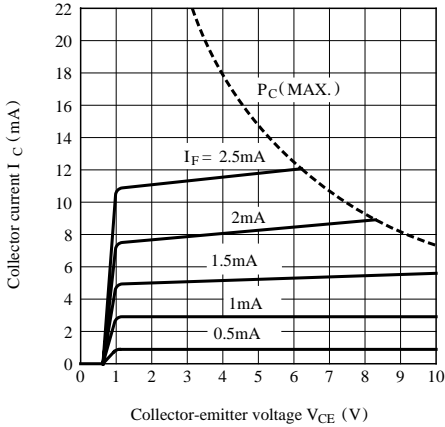

Fig. 5-b Collector Current vs. Collector-emitter Voltage (GP1S22)

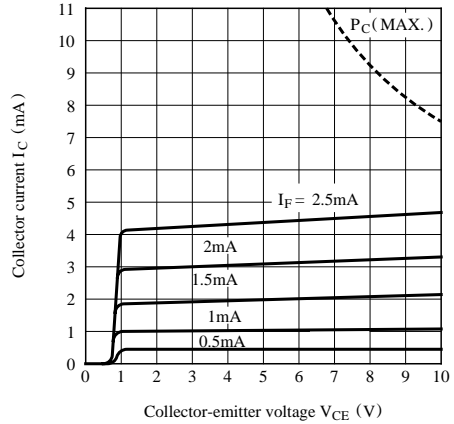

Fig. 6 Collector Current vs. Ambient Temperature

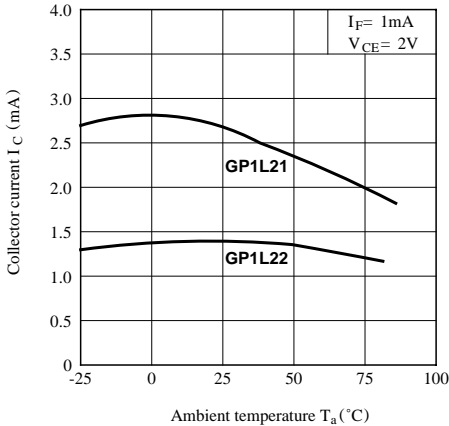

Fig. 7 Collector-emitter Saturation Voltage vs. Ambient Temperature

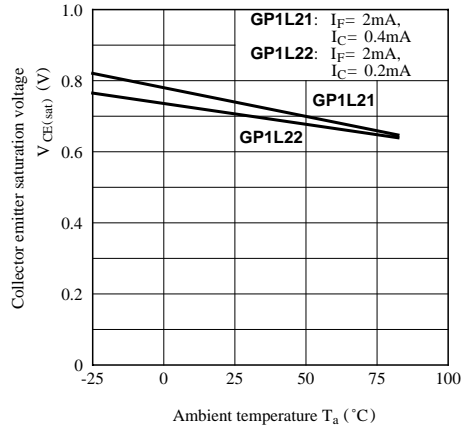
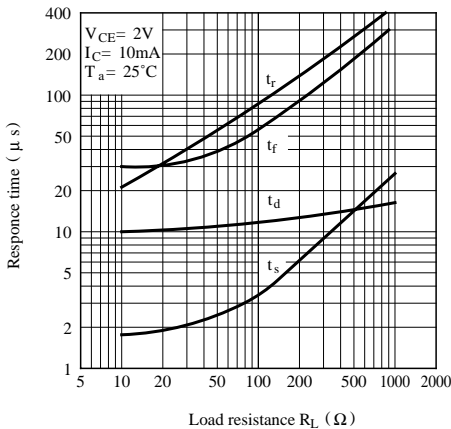

Fig. 8 Response Time vs. Load Resistance



Test Circuit for Response Time

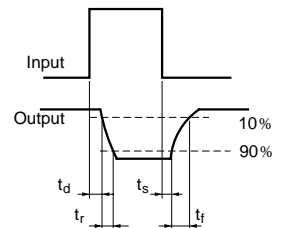
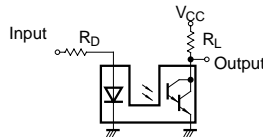

Fig. 9 Collector Dark Current vs. Ambient Temperature

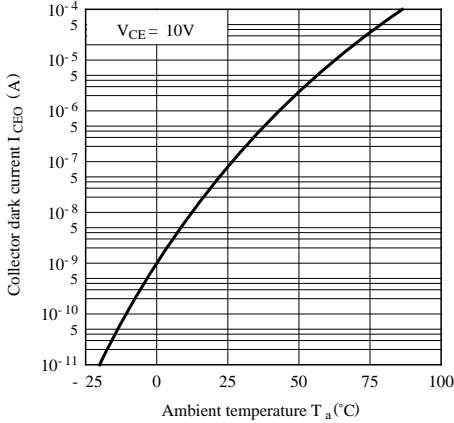
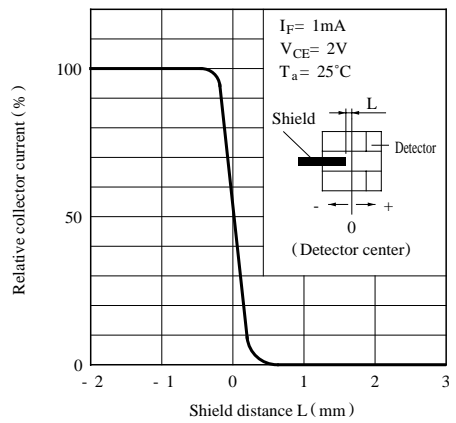

Fig.10-a Relative Collector Current vs. Shield Distance (1) (GP1L21)





LittleDiode supplies new, hard to find or obsolete electronic components and semiconductors all over the world.

With over two million different components listed you are sure to find the part you need.

Feel free to visit us today at our online store:

LittleDiode.com

Looking forward to providing you with the best possible service.