

GP1A52LR

OPIC Photointerrupter

■ Features

1. Output inverting type of **GP1A52HR**
2. High sensing accuracy (Slit width: 0.5mm)
3. TTL and CMOS compatible output
4. PWB mounting type

■ Applications

1. OA equipment, such as printers, floppy disk drives, etc.
2. VCRs

■ Outline Dimensions

(Unit : mm)

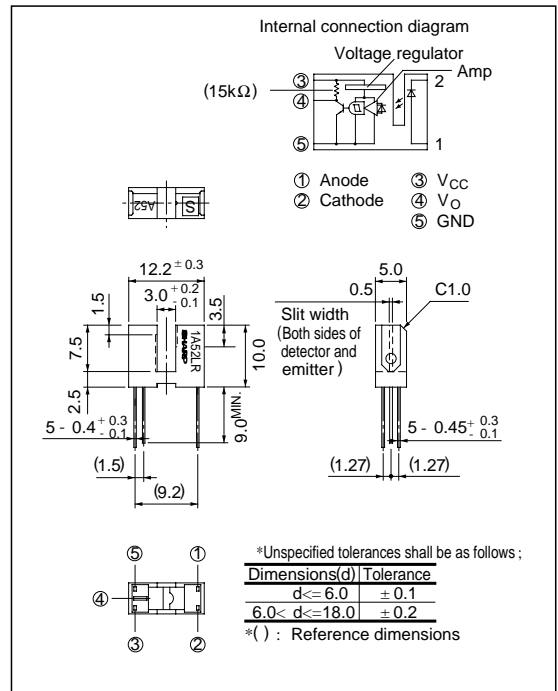

*** OPIC™ (Optical IC) is a trademark of the SHARP Corporation.
An OPIC consists of a light-detecting element and signal-processing circuit integrated onto a single chip.

■ Absolute Maximum Ratings

(Ta = 25°C)

Parameter		Symbol	Rating	Unit
Input	Forward current	I _F	50	mA
	*1 Peak forward current	I _{FM}	1	A
	Reverse voltage	V _R	6	V
	Power dissipation	P	75	mW
Output	Supply voltage	V _{CC}	- 0.5 to + 17	V
	Low level output current	I _{OL}	50	mA
	Power dissipation	P _O	250	W
Operating temperature		T _{opr}	- 25 to + 85	°C
Storage temperature		T _{stg}	- 40 to + 100	°C
*2 Soldering temperature		T _{sol}	260	°C

*1 Pulse width ≤ 100 μ s, Duty ratio = 0.01

*2 For 5 seconds

Electro-optical Characteristics

(Ta = 25°C)

Parameter		Symbol	Conditions	MIN.	TYP.	MAX.	Unit	
Input	Forward voltage	V_F	$I_F = 5\text{mA}$	-	1.1	1.4	V	
	Reverse current	I_R	$V_R = 3\text{V}$	-	-	10.0	μA	
Output	Operating supply voltage	V_{CC}		4.5	-	17.0	V	
	Low level output voltage	V_{OL}	$V_{CC} = 5\text{V}, I_F = 5\text{mA}, I_{OL} = 16\text{mA}$	-	0.15	0.4	V	
	High level output voltage	V_{OH}	$V_{CC} = 5\text{V}, I_F = 0\text{mA}$	4.9	-	-	V	
	Low level supply current	I_{CCL}	$V_{CC} = 5\text{V}, I_F = 5\text{mA}$	-	1.7	3.8	mA	
	High level supply current	I_{CCH}	$V_{CC} = 5\text{V}, I_F = 0\text{mA}$	-	0.7	2.2	mA	
	Transfer characteristics	^{*3} “High→Low” threshold input current	I_{FHL}	$V_{CC} = 5\text{V}$	-	1.0	5.0	mA
^{*4} Hysteresis		I_{FLH} / I_{FHL}	$V_{CC} = 5\text{V}$	0.55	0.75	0.95		
Response time		“High→Low” propagation delay time	t_{PHL}	$V_{CC} = 5\text{V}, I_F = 5\text{mA}$ $R_L = 280\Omega$	-	3.0	9.0	μs
		“Low→High” propagation delay time	t_{PLH}		-	5.0	15.0	
		Rise time	t_r		-	0.1	0.5	
	Fall time	t_f	-		0.05	0.5		

*3 I_{FHL} represents forward current when output changes from high to low.

*4 I_{FLH} represents forward current when output changes from low to high.

Hysteresis stands for I_{FLH} / I_{FHL} .

Recommended Operating Conditions

Parameter	Symbol	Operating temp.	MIN.	MAX.	Unit
Low level output current	I_{OL}	Ta = 0 to + 70°C	-	16.0	mA
Forward current	I_F		10.0	20.0	mA

Fig. 1 Forward Current vs. Ambient Temperature

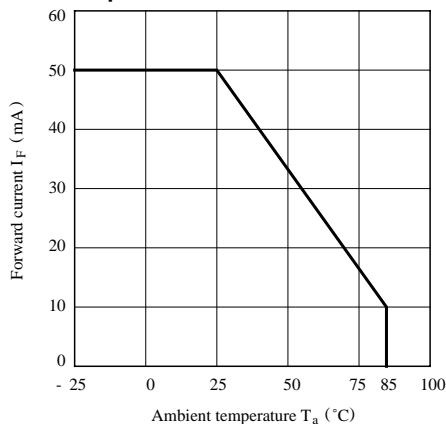

Fig. 2 Output Power Dissipation vs. Ambient Temperature

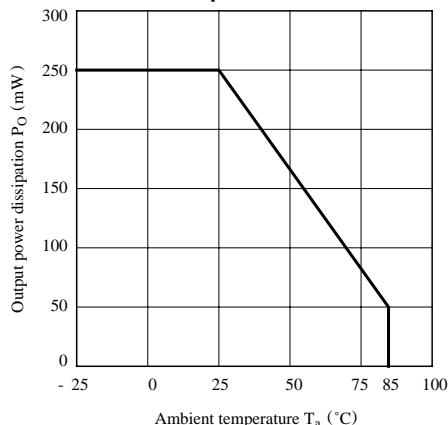

Fig. 3 Low Level Output Current vs. Ambient Temperature

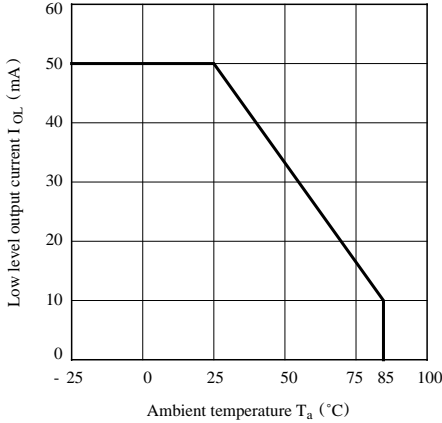

Fig. 4 Forward Current vs. Forward Voltage

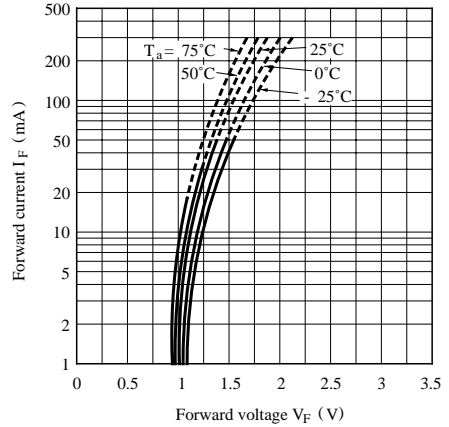

Fig. 5 Relative Threshold Input Current vs. Supply Voltage

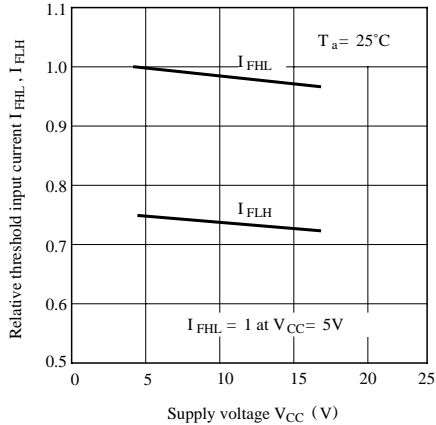

Fig. 6 Relative Threshold Input Current vs. Ambient Temperature

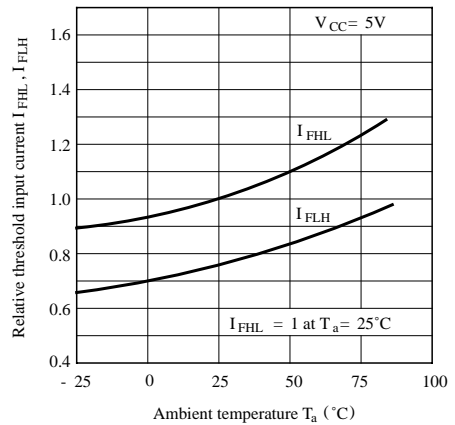

Fig. 7 Low Level Output Voltage vs. Low Level Output Current

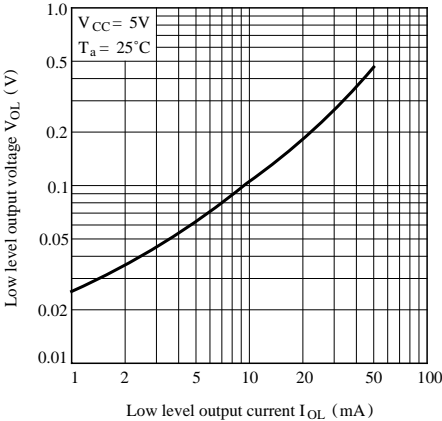

Fig. 8 Low Level Output Voltage vs. Ambient Temperature

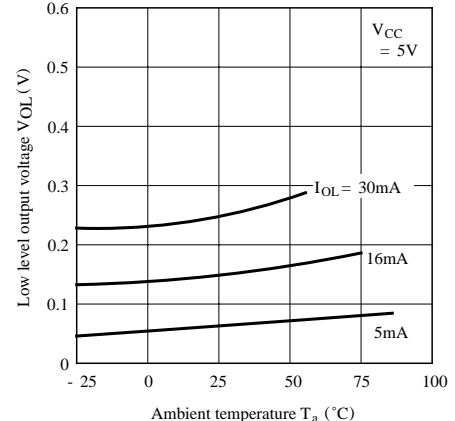

Fig. 9 Supply Current vs. Ambient Temperature

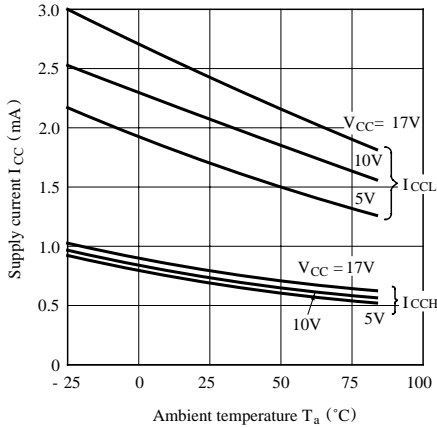

Fig.10 Propagation Delay Time vs. Forward Current

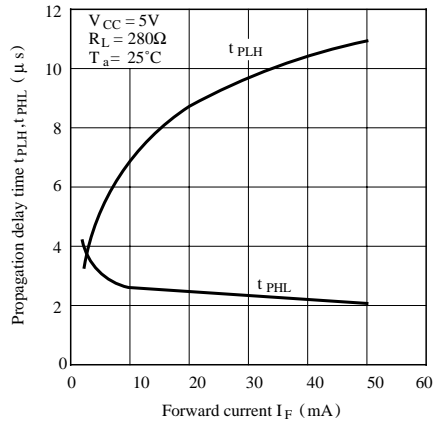
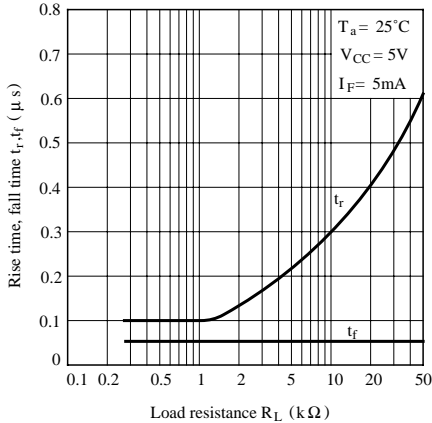
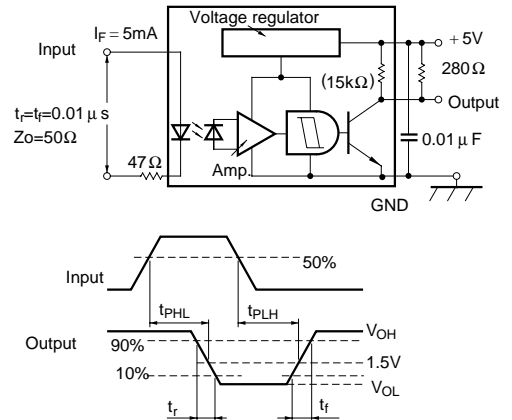

Fig.11 Rise Time, Fall Time vs. Load Resistance



Test Circuit for Response Time



■ Precautions for Use

- (1) In case of cleaning, use only the following type of cleaning solvent.
Ethyl alcohol, Methyl alcohol, Isopropyl alcohol
- (2) In order to stabilize power supply line, connect a by-pass capacitor of more than 0.01 µF between Vcc and GND near the device.
- (3) As for other general cautions refer to the chapter “Precautions for Use”.



LittleDiode supplies new, hard to find or obsolete electronic components and semiconductors all over the world.

With over two million different components listed you are sure to find the part you need.

Feel free to visit us today at our online store:

LittleDiode.com

Looking forward to providing you with the best possible service.