

GP1A33R

OPIC Photointerrupter with Encoder Function

■ Features

1. 2-phase (A, B) digital output
2. Capable of using plastic disk
3. Sensing accuracy
(Disk slit pitch: 1.14mm)
4. TTL compatible
5. Compact and light

■ Applications

1. Electronic typewriters, printers
2. Numerical control machines

■ Outline Dimensions

(Unit: mm)

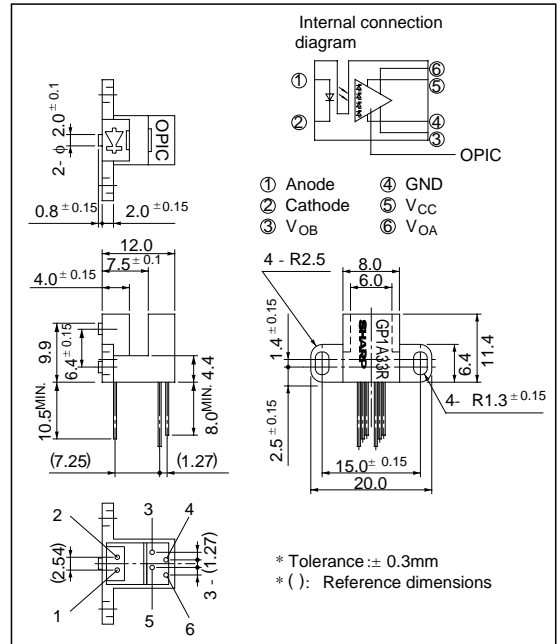

*** OPIC™ (Optical IC) is a trademark of the SHARP Corporation.
An OPIC consists of a light-detecting element and signal-processing circuit integrated onto a single chip.

■ Absolute Maximum Ratings

(Ta= 25°C)

	Parameter	Symbol	Rating	Unit
Input	Forward current	I _F	65	mA
	*1 Peak forward current	I _{FM}	1	A
	Reverse Voltage	V _R	6	V
	Power dissipation	P	100	mW
Output	Supply voltage	V _{CC}	7	V
	Low level output current	I _{OL}	20	mA
	Power dissipation	P _O	250	mW
Operating temperature		T _{opr}	0 to + 70	°C
Storage temperature		T _{stg}	- 40 to + 80	°C
*2 Soldering temperature		T _{sol}	260	°C

*1 Pulse width ≤ 100 μs, Duty ratio = 0.01

*2 For 5 seconds

Electro-optical Characteristics

(Unless otherwise specified, Ta = 0 to + 70°C)

Parameter		Symbol	Conditions	MIN.	TYP.	MAX.	Unit
Input	Forward voltage	V _F	Ta = 25°C, I _F = 30mA	-	1.2	1.5	V
	Reverse current	I _R	Ta = 25°C, V _R = 3V	-	-	10	μ A
Output	Operating supply voltage	V _{CC}		4.5	5.0	5.5	V
	High level output voltage	V _{OH}	^{*3} V _{CC} = 5V, I _F = 30mA	2.4	4.9	-	V
	Low level output voltage	V _{OL}	^{*3} I _{OL} = 8mA, V _{CC} = 5V, I _F = 30mA	-	0.1	0.4	V
	Supply current	I _{CC}	^{*3*4} I _F = 30mA, V _{CC} = 5V	-	5	20	mA
Transfer characteristics	Duty ratio	D _A ^{*5}	V _{CC} = 5V, I _F = 30mA, ^{*3} f = 2.5kHz	20	50	80	%
		D _B ^{*5}		20	50	80	%
	Response frequency	f _{MAX.}	^{*3} V _{CC} = 5V, I _F = 30mA	-	-	5	kHz

*3 Measured under the condition shown in Measurement Condition.

*4 In the condition that output A and B are low level.

*5 $D_A = \frac{t_{AH}}{t_{AP}} \times 100$, $D_B = \frac{t_{BH}}{t_{BP}} \times 100$

Output Waveforms

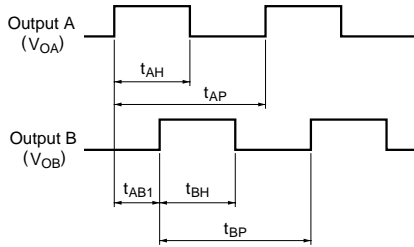

Rotational direction : Counterclockwise when seen from OPIC light detector

Fig. 1 Forward Current vs. Ambient Temperature

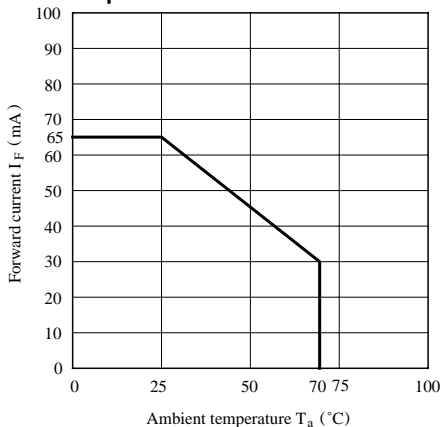

Fig. 2 Output Power Dissipation vs. Ambient Temperature

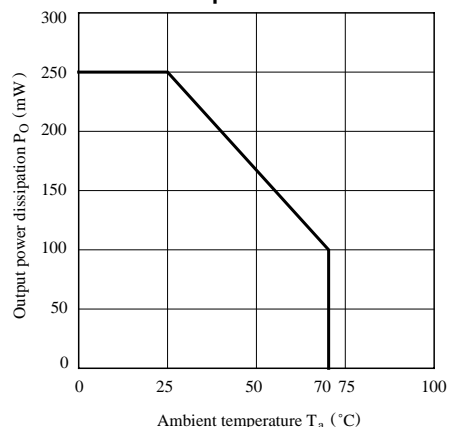

Fig. 3 Duty Ratio vs. Frequency

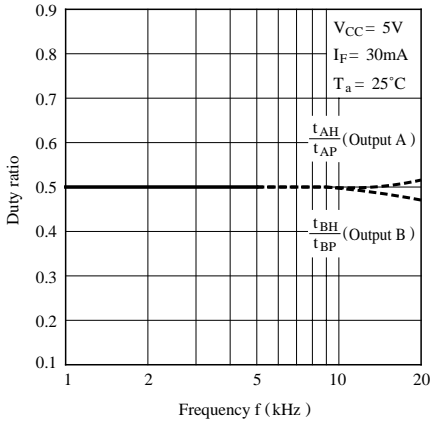

Fig. 4 Phase Difference vs. Frequency Temperature

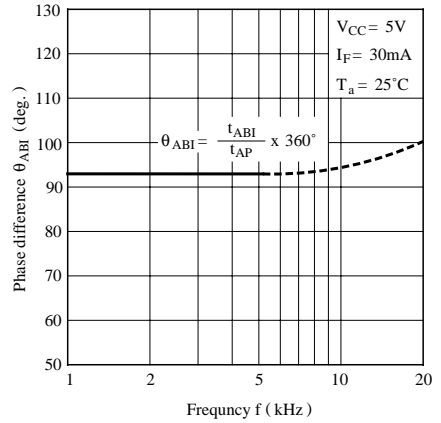

Fig. 5 Duty Ratio vs. Ambient Temperature

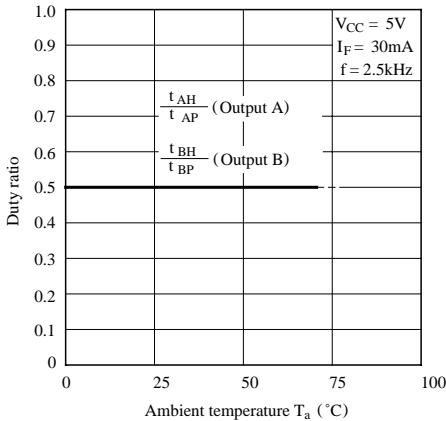

Fig. 6 Phase Difference vs. Ambient Temperature

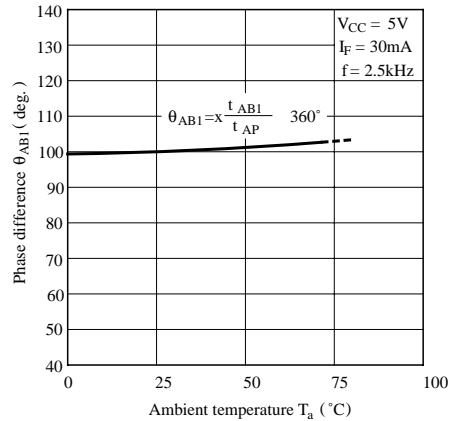

Fig. 7 Duty Ratio vs. Distance (X direction)

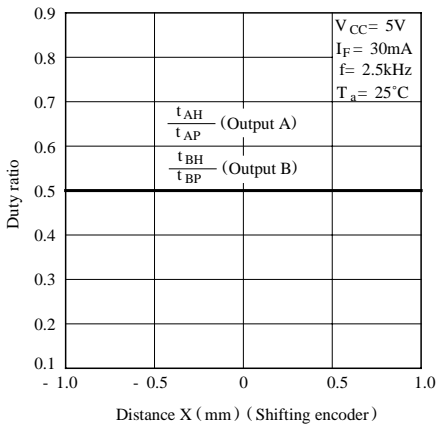

Fig. 8 Phase Difference vs. Distance (X direction)

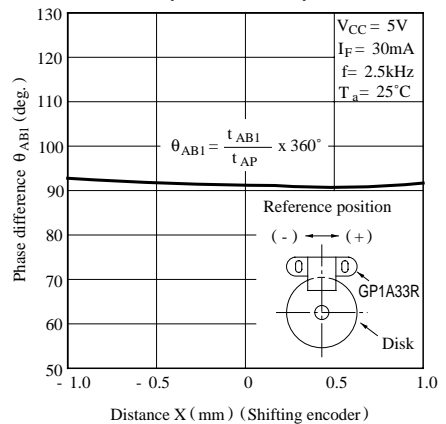

Fig. 9 Duty Ratio vs. Distance (Y direction)

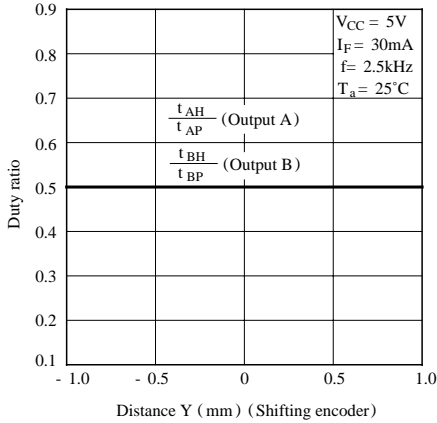

Fig.10 Phase Difference vs. Distance (Y direction)

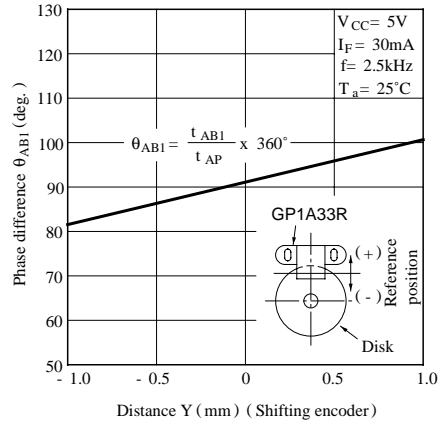

Fig.11 Duty Ratio vs. Distance (Z direction)

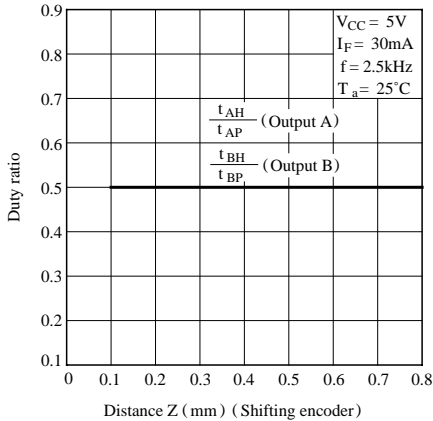
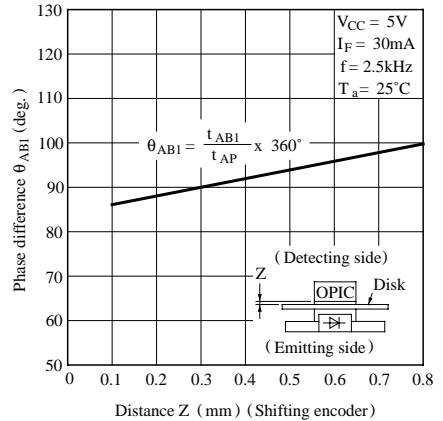
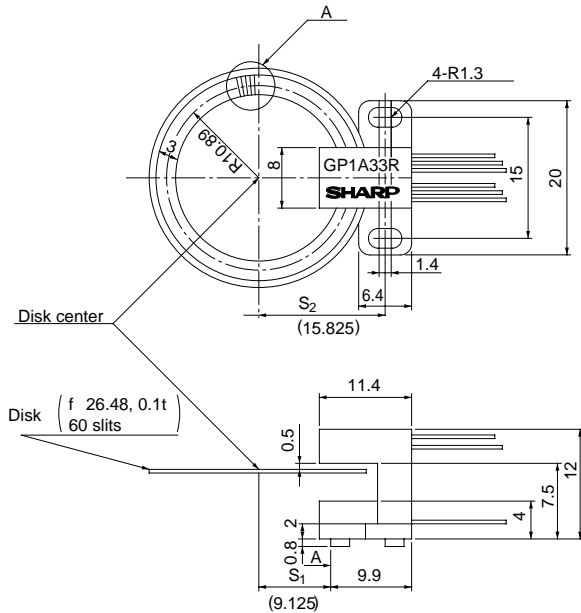

Fig.12 Phase Difference vs. Distance (Z direction)



Measurement Conditions



<Basic Design>

R_0 (distance between the disk center and half point of a slit),
 P (slit pitch), S_1 and S_2 (installing position of photointerrupter) will be provided by the following equations.

Slit pitch : P (slit center)

$$R_0 = \frac{N}{60} \times 10.89 \text{ (mm)} \quad N: \text{ number of slits}$$

$$P = \frac{2 \times p \times R_0}{N} \text{ (mm)}$$

$$S_1 = R_0 - 1.765 \text{ (mm)}, S_2 = S_1 + 6.7 \text{ (mm)}$$

Note) When the number of slits is changed, values in parenthesis are also changed according to the number.

Enlarged drawing of A portion

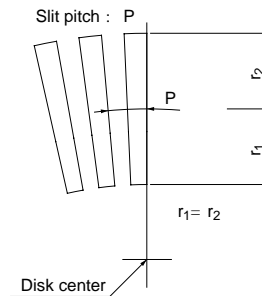

(Ex.) In the case of
 $N = 100P/R$

$$R_0 = \frac{100}{60} \times 10.89 \text{ (mm)}$$

$$= 18.15 \text{ mm}$$

$$P = \frac{2 \times p \times 18.15}{100}$$

$$= 1.14 \text{ mm}$$

$$S_1 = 18.15 - 1.765$$

$$= 16.385 \text{ mm}$$

$$S_2 = 16.385 + 6.7$$

$$= 23.085 \text{ mm}$$

■ Precautions for Use

- (1) This module is designed to be operated at $I_F = 30 \text{ mA}$ TYP.
- (2) Fixing torque : MAX. $0.6 \text{ N} \cdot \text{m}$
- (3) In order to stabilize power supply line, connect a by-pass capacitor of more than $0.01 \mu\text{F}$ between V_{CC} and GND near the device.
- (4) As for other general cautions, refer to the chapter "Precautions for Use".



LittleDiode supplies new, hard to find or obsolete electronic components and semiconductors all over the world.

With over two million different components listed you are sure to find the part you need.

Feel free to visit us today at our online store:

LittleDiode.com

Looking forward to providing you with the best possible service.