

# GL3□□43 Series $\phi 3\text{mm}$ (T-1) Cylinder Type LED Lamps

## Model No.

GL3UR43 Red (Super-luminosity)	GaAlAs/GaAlAs
GL3LR43 Red (High-luminosity)	GaAlAs/GaAs
GL3TR43 Red (High-luminosity)	GaAlAs/GaAs
GL3PR43 Red	GaP
GL3HD43 Red	GaAsP/GaP
GL3HS43 Sunset orange	GaAsP/GaP
GL3HY43 Yellow	GaAsP/GaP
GL3EG43 Yellow-green	GaP
GL3KG43 Green	GaP

## Outline Dimensions

(Unit: mm)

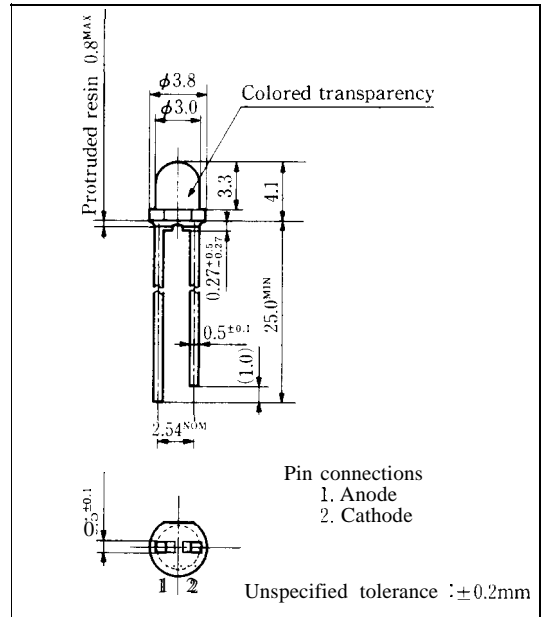

## Features

- $\phi 3\text{mm}$ (T-1) all resin mold
- Colored transparency lens type
- Wide viewing angle

## Absolute Maximum Ratings

(Ta = 25°C)

Parameter	Symbol	GL3UR43	GL3LR43	GL3PR43	GL3HD43	GL3EG43	Unit	
			GL3TR43		GL3HS43	GL3KG43		
					GL3HY43			
Power dissipation	P	75	110	23	84	84	mW	
Continuous forward current	I <sub>F</sub>	30	50	10	30	30	mA	
*1 Peak forward current	I <sub>FM</sub>	50	300	50	50	50	mA	
Derating factor	DC	—	0.40	0.67	0.13	0.40	0.40	mA/°C
	Pulse	—	0.67	4.00	0.67	0.67	0.67	mA/°C
Reverse voltage	V <sub>R</sub>	4	5	5	5	5	V	
Operating temperature	T <sub>opr</sub>	-25 to +85						°C
Storage temperature	T <sub>stg</sub>	-25 to +100						°C
*2 Soldering temperature	T <sub>sol</sub>	260(within 5 seconds)						°C

\*1 Duty ratio = 1/10, Pulse width = 0.1ms

Duty ratio = 1/16, Pulse width  $\leq 1\text{ms}$  for GL3LR43 and GL3TR43

\*2 At the position of 1.6mm from the bottom face of resin package

GL3UR43 (Red)

■ Electro-optical Characteristics

(Ta = 25°C)

Parameter	Symbol	Model No.	Conditions	MIN.	TYP.	MAX.	Unit
Forward voltage	$V_F$	GL3UR43	$I_F = 20\text{mA}$	-	185	2.5	V
*3 Luminous intensity	$I_v$	GL3UR43	$I_F = 20\text{mA}$	50	100	-	mcd
Peak emission wavelength	$\lambda_p$	GL3UR43	$I_F = 20\text{mA}$	-	660	-	nm
Spectrum radiation bandwidth	$\Delta\lambda$	GL3UR43	$I_F = 20\text{mA}$	-	20	-	nm
Reverse current	$I_R$	GL3UR43	$V_R = 3\text{V}$	-	-	100	$\mu\text{A}$
Terminal capacitance	$C_t$	GL3UR43	$V = 0\text{V}$ $f = \text{MHz}$	-	25	-	pF
Response frequency	$f_c$	GL3UR43	-	-	8	-	MHz

\*3 Tolerance:  $\pm 30\%$

■ Characteristics Diagrams

Forward Current vs. Forward Voltage (Ta = 25°C)

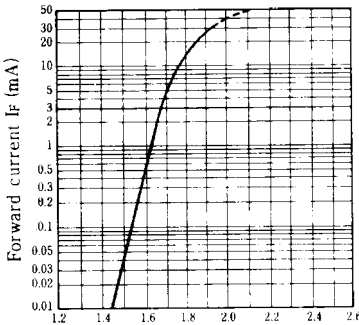

Forward voltage  $V_F$  (V)

Luminous Intensity vs. Forward Current (Ta = 25°C)

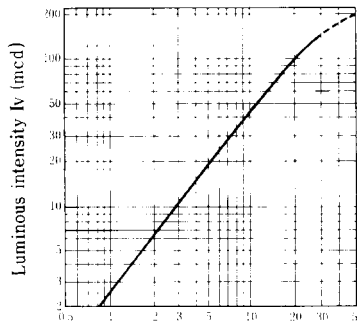

Forward current  $I_F$  (mA)

Forward Current Derating Curve

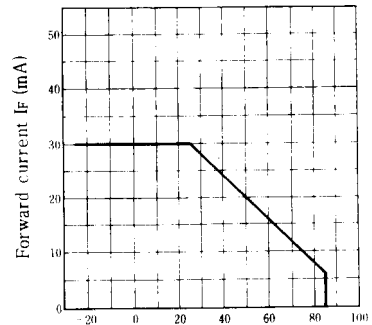

Ambient temperature  $T_a$  (°C)

Relative Luminous Intensity vs. Ambient Temperature (I\_F = 20mA)

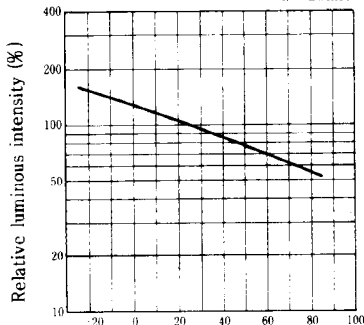

Ambient temperature  $T_a$  (°C)

Spectrum Distribution (Ta = 25°C)

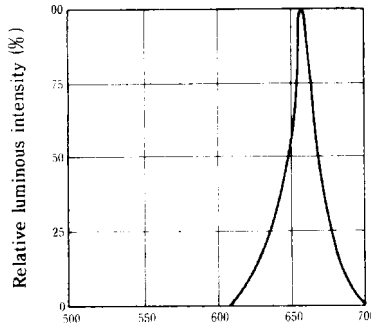

Wavelength  $\lambda$  (nm)

Radiation Diagram (Ta = 25°C)

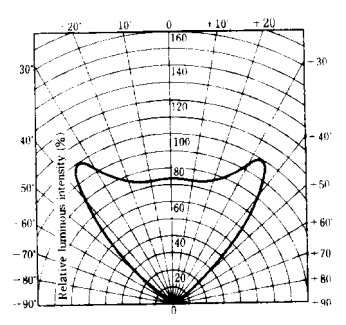

GL3LR43 (Red) / GL3TR43 (Red)

■ Electro-optical Characteristics

(Ta = 25°C)

Parameter	Symbol	Model No.	Conditions	MIN.	TYP.	MAX.	Unit
Forward voltage	V <sub>F</sub>	GL3LR43	I <sub>F</sub> = 20mA	—	1.75	2.2	V
		GL3TR43	I <sub>F</sub> = 20mA		1.75	2.2	
※3 Luminous intensity	I <sub>v</sub>	GL3LR43	I <sub>F</sub> = 20mA	20	40	—	cd
		GL3TR43	I <sub>F</sub> = 20mA	10	20	—	
Peak emission wavelength	λ <sub>p</sub>	GL3LR43	I <sub>F</sub> = 20mA	—	660	—	nm
		GL3TR43	I <sub>F</sub> = 20mA		660	—	
Spectrum radiation bandwidth	Δλ	GL3LR43	I <sub>F</sub> = 20mA		20	—	nm
		GL3TR43	I <sub>F</sub> = 20mA	—	20	—	
Reverse current	I <sub>R</sub>	GL3LR43	V <sub>R</sub> = 4V	—	—	10	μA
		GL3TR43	V <sub>R</sub> = 4V	—	—	10	
Terminal capacitance	C <sub>t</sub>	GL3LR43	V = 0V f = 1 MHz	—	30	—	pF
		GL3TR43	V = 0V f = 1 MHz	—	30	—	
Response frequency	f <sub>c</sub>	GL3LR43	—	—	8	—	MHz
		GL3TR43	—	—	8	—	

※3 Tolerance: ±30%

■ Characteristics Diagrams

Forward Current vs. Forward Voltage

(Ta = 25°C)

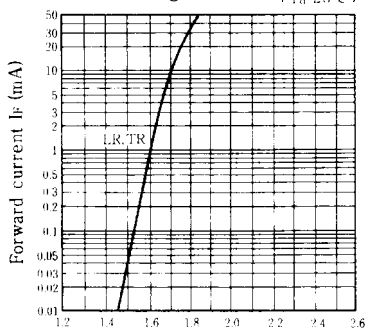

Forward voltage V<sub>F</sub> (V)

Luminous Intensity vs. Forward Current

(Ta = 25°C)

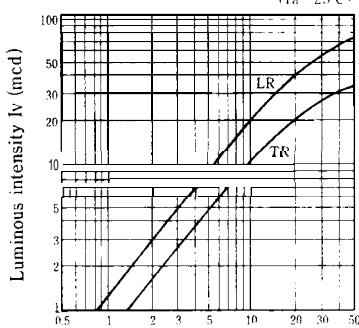

Forward current I<sub>F</sub> (mA)

Forward Current Derating Curve

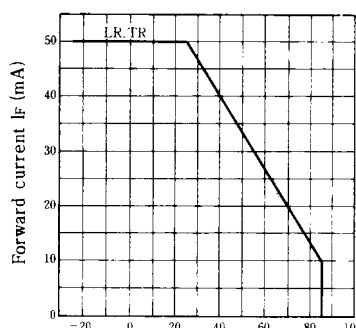

Ambient temperature, Ta (°C)

Relative Luminous Intensity vs. Ambient Temperature

(I<sub>F</sub> = 20mA)

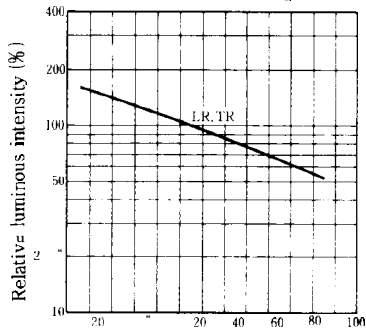

Ambient temperature Ta (°C)

Spectrum Distribution

(Ta = 25°C)

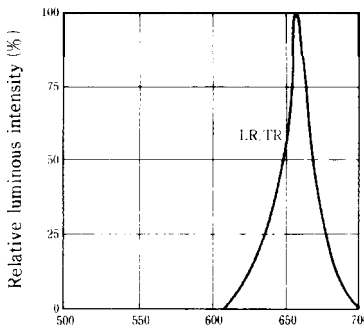

Wavelength λ (nm)

Radiation Diagram

(Ta = 25°C)

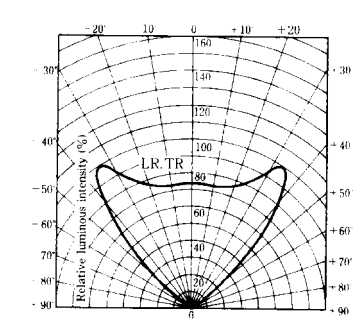

## GL3PR43 (Red) / GL3HD43 (Red)

■ **Electro-optical** Characteristics

(Ta = 25°C)

Parameter	Symbol	Model No.	Conditions	MIN.	TYP.	MAX.	Unit
Forward voltage	V <sub>F</sub>	GL3PR43	I <sub>F</sub> = 5mA	—	1.9	2.3	V
		GL3HD43	I <sub>F</sub> = 20mA	—	2.0	2.8	
※3 Luminous intensity	I <sub>v</sub>	GL3PR43	I <sub>F</sub> = 5mA	1.0	3.0	—	mcd
		GL3HD43	I <sub>F</sub> = 20mA	7.0	25	—	
Peak emission wavelength	λ <sub>p</sub>	GL3PR43	I <sub>F</sub> = 5mA	—	695	—	‘m
		GL3HD43	I <sub>F</sub> = 20mA	—	635	—	
Spectrum radiation bandwidth	Δλ	GL3PR43	I <sub>F</sub> = 5mA	—	100	—	‘m
		GL3HD43	I <sub>F</sub> = 20mA	—	35	—	
Reverse current	I <sub>R</sub>	GL3PR43	V <sub>R</sub> = 4V	—	—	10	μA
		GL3HD43	V <sub>R</sub> = 4V	—	—	10	
Terminal capacitance	C <sub>t</sub>	GL3PR43	V = 0V f = 1MHz	—	55	—	pF
		GL3HD43	V = 0V f = 1MHz	—	20	—	
Response frequency	f <sub>c</sub>	GL3PR43	—	—	4	—	MHz
		GL3HD43	—	—	4	—	

※3 Tolerance: ±30%

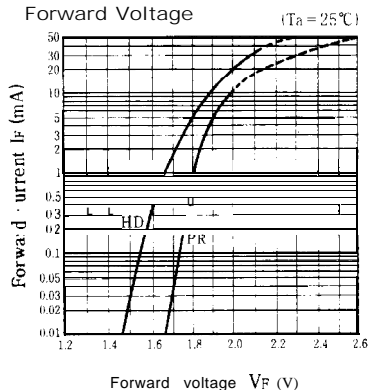
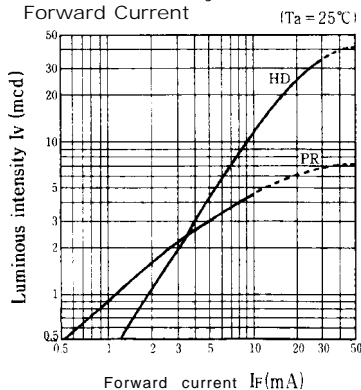
■ **Characteristics Diagrams**Forward Current vs.  
Forward VoltageLuminous Intensity vs.  
Forward Current

Forward Current Derating Curve

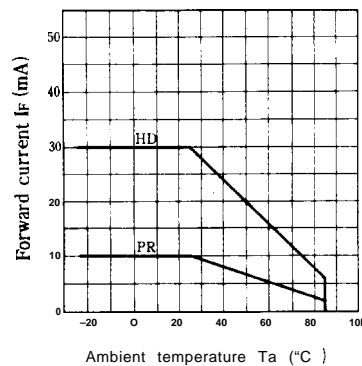
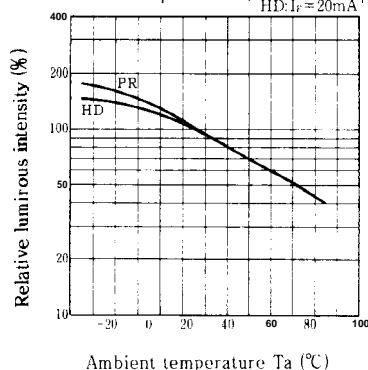
Relative Luminous Intensity vs.  
Ambient Temperature, PR: I<sub>F</sub> = 5mA  
HD: I<sub>F</sub> = 20mA

Spectrum Distribution

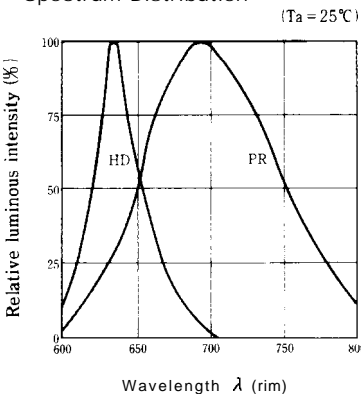

Radiation Diagram

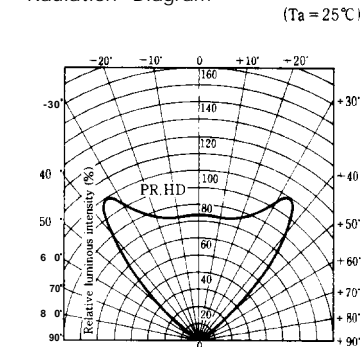

GL3HS43 (Sunset orange) / GL3HY43 (Yellow)

■ **Electro-optical** Characteristics

(Ta = 25°C)

Parameter	Symbol	Model No.	Conditions	MIN.	TYP.	MAX.	Unit
Forward voltage	V <sub>F</sub>	GL3HS43	I <sub>F</sub> = 20mA	—	2.0	2,8	V
		GL3HY43	I <sub>F</sub> = 20mA	—	2.0	2.8	
*3 Luminous intensity	I <sub>v</sub>	GL3HS43	I <sub>F</sub> = 20mA	7,0	25	—	'cd
		GL3HY43	I <sub>F</sub> = 20mA	7.0	25	—	
Peak emission wavelength	λ <sub>p</sub>	GL3HS43	I <sub>F</sub> = 20mA	—	610	—	'm
		GL3HY43	I <sub>F</sub> = 20mA	—	585	—	
Spectrum radiation bandwidth	Δλ	GL3HS43	I <sub>F</sub> = 20mA	—	35	—	'm
		GL3HY43	I <sub>F</sub> = 20mA	—	30	—	
Reverse current	I <sub>R</sub>	GL3HS43	V <sub>R</sub> = 4V	—	—	10	μA
		GL3HY43	V <sub>R</sub> = 4V	—	—	10	
Terminal capacitance	C <sub>t</sub>	GL3HS43	V = 0V f = 1 MHz	—	15	—	pF
		GL3HY43	V = 0V f = 1MHz	—	35	—	
Response frequency	f <sub>c</sub>	GL3HS43	—	—	4	—	'Hz
		GL3HY43	—	—	4	—	

\*3 Tolerance: ±30%

3

■ **Characteristics Diagrams**

Forward Current vs. Forward Voltage (Ta = 25°C)

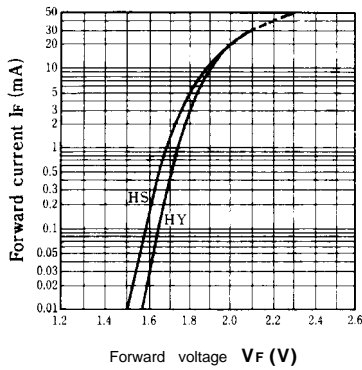

Luminous Intensity vs. Forward Current (Ta = 25°C)

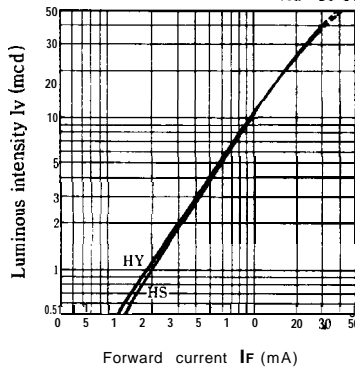

Forward Current Derating Curve

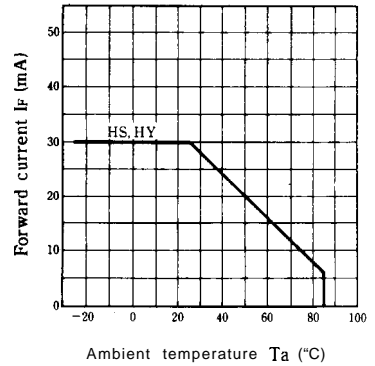

Relative Luminous Intensity vs. Ambient Temperature (If = 20mA)

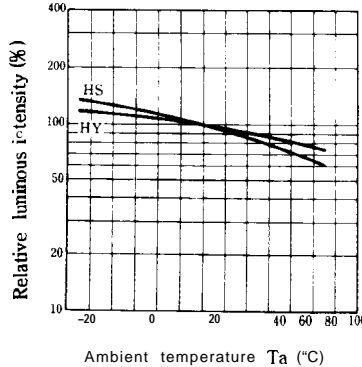

Spectrum Distribution (Ta = 25°C)

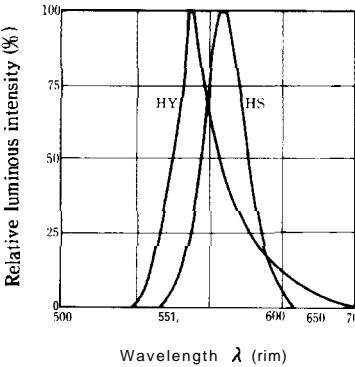

Radiation Diagram (Ta = 25°C)

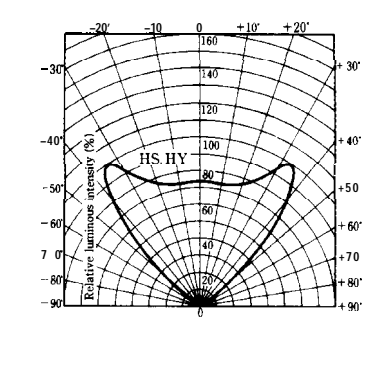

GL3EG43 (Yellow-green) / GL3KG43 (Green)

■ Electro-optical Characteristics

(Ta = 25°C)

Parameter	Symbol	Model No.	Conditions	MIN.	TYP.	MAX.	Unit
Forward voltage	V <sub>F</sub>	GL3EG43	I <sub>F</sub> = 20mA		2.1	2.8	V
		GL3KG43	I <sub>F</sub> = 20mA	-	2.1	2.8	
※3 Luminous intensity	I <sub>v</sub>	GL3EG43	I <sub>F</sub> = 20mA	10	25	-	'cd
		GL3KG43	I <sub>F</sub> = 20mA	8.0	20	-	
Peak emission wavelength	λ <sub>p</sub>	GL3EG43	I <sub>F</sub> = 20mA	-	565	-	nm
		GL3KG43	I <sub>F</sub> = 20mA	-	555	-	
Spectrum radiation bandwidth	Δλ	GL3EG43	I <sub>F</sub> = 20mA	-	30	-	'm
		GL3KG43	I <sub>F</sub> = 20mA	-	25	-	
Reverse current	I <sub>R</sub>	GL3EG43	V <sub>R</sub> = 4V	-	-	10	μA
		GL3KG43	V <sub>R</sub> = 4V	-	-	10	
Terminal capacitance	C <sub>t</sub>	GL3EG43	V = 0V f = 1MHz	-	35	-	pF
		GL3KG43	V = 0V f = 1MHz	-	4(1)	-	
Response frequency	f <sub>c</sub>	GL3EG43	-	-	4	-	MHz
		GL3KG43	-	-	4	-	

※3 Tolerance: ±30%

■ Characteristics Diagrams

Forward Current vs. Forward Voltage (Ta = 25°C)

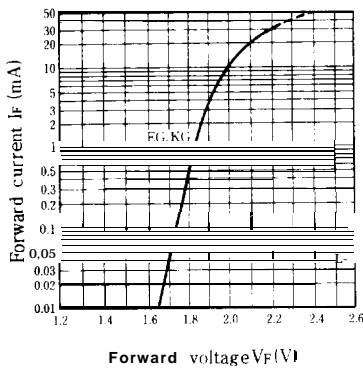

Luminous Intensity vs. Forward Current (Ta = 25°C)

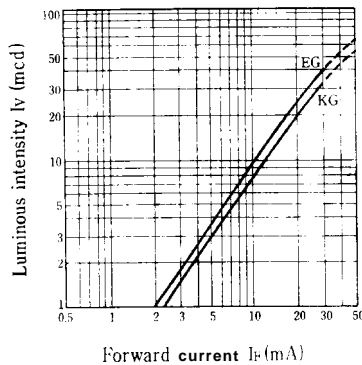

Forward Current Derating Curve

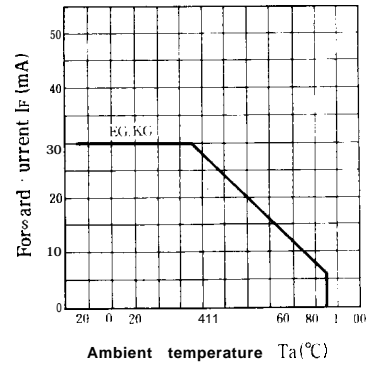

Relative Luminous Intensity vs. Ambient Temperature (If = 20mA)

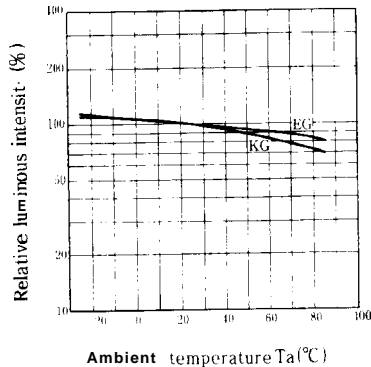

Spectrum Distribution (Ta = 25°C)

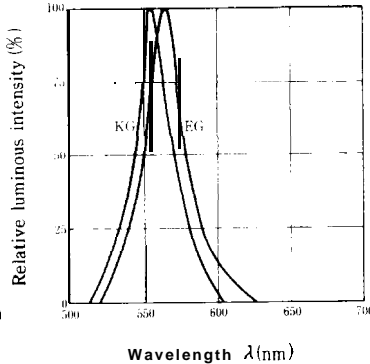

Radiation Diagram (Ta = 25°C)

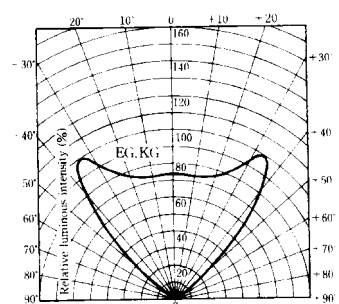



LittleDiode supplies new, hard to find or obsolete electronic components and semiconductors all over the world.

With over two million different components listed you are sure to find the part you need.

Feel free to visit us today at our online store:

[LittleDiode.com](http://LittleDiode.com)

Looking forward to providing you with the best possible service.