

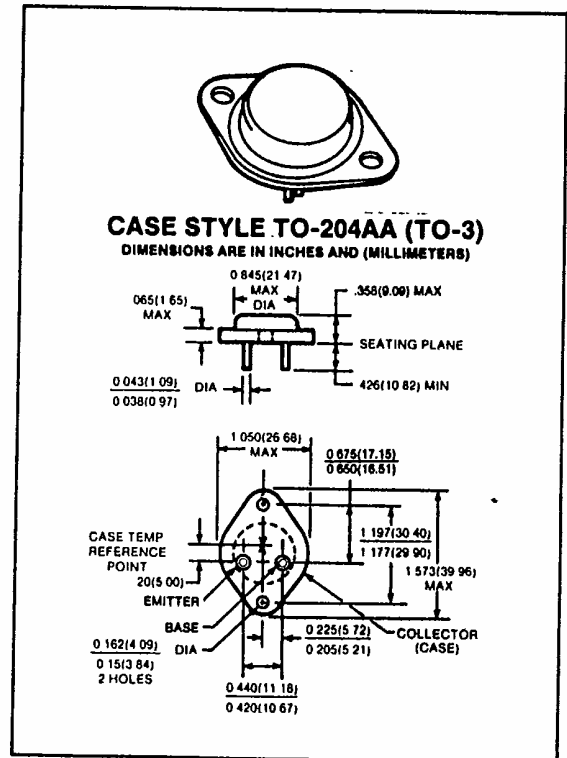

HIGH SPEED NPN POWER DARLINGTON TRANSISTORS

GE5060,1,2
400-500 VOLTS
20 AMP, 125 WATTS

These devices are designed for use in high speed switching applications, such as off-line switching power supplies, AC & DC motor control, UPS systems, ultrasonic equipment and other high frequency power conversion equipment.

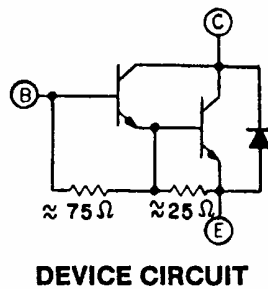

maximum ratings ($T_C = 25^\circ C$) (unless otherwise noted)

RATING	SYMBOL	GE5060	GE5061	GE5062	UNITS
Collector-Base Voltage	V_{CB0}	400	450	500	Volts
Collector-Emitter Voltage	V_{CE0}	350	400	450	Volts
Emitter Base Voltage	V_{EB0}	8	8	8	Volts
Collector Current — Continuous	I_C	20	20	20	A
Peak (Repetitive)	I_{CM}	25	25	25	
Peak (Non-Repetitive)	I_{CSM}	42.5	42.5	42.5	
Base Current — Continuous	I_B	4	4	4	A
Peak (Non-Repetitive)	I_{BM}	6	6	6	
Total Power Dissipation @ $T_C = 25^\circ C$	P_D	125	125	125	Watts
Operating and Storage Junction Temperature Range	T_J, T_{STG}	-65 to +150	-65 to +150	-65 to +150	$^\circ C$

thermal characteristics

Thermal Resistance, Junction to Case	$R_{\theta JC}$	1	1	1	$^\circ C/W$
Maximum Lead Temperature for Soldering Purposes: $\frac{1}{8}$ " from Case for 5 Seconds	T_L	300	300	300	$^\circ C$

electrical characteristics ($T_C = 25^\circ C$) (unless otherwise specified)

CHARACTERISTIC	SYMBOL	MIN	TYP	MAX	UNIT
----------------	--------	-----	-----	-----	------

off characteristics⁽¹⁾

Collector-Emitter Sustaining Voltage ($I_C = .5mA$) ($V_{clamp} = V_{CEO}$ Rated)	GE5060 GE5061 GE5062	$V_{CEO(sus)}$	350 400 450	— — —	— — —	Volts
Collector-Base Voltage ($I_C = 0.25mA$)	GE5060 GE5061 GE5062	V_{CBO}	400 450 500	— — —	— — —	Volts
Collector Cutoff Current ($V_{CB} = V_{CBO}$ Rated)		I_{CBO}	—	—	.25	mA
Emitter Cutoff Current ($V_{EB} = 4.5V, I_C = 0$)		I_{EBO}	—	—	200	mA

second breakdown

Second Breakdown with Base Forward Biased	FBSOA	SEE FIGURE 16
Clamped Inductive soa with Base Reversed Bias	RBSOA	SEE FIGURE 17

on characteristics

DC Current Gain ($I_C = 10A, V_{CE} = 5V$) ($I_C = 15A, V_{CE} = 5V$) ($I_C = 20A, V_{CE} = 5V$)	h_{FE}	100 40 15	160 115 65	— — —	—
Collector-Emitter Saturation Voltage ($I_C = 10A, I_B = 1A$) ($I_C = 10A, I_B = 2A$) ($I_C = 20A, I_B = 2.0A$)	$V_{CE(sat)}$	— — —	1.20 1.15 1.6	1.5 1.4 2.0	V
Base-Emitter Voltage ($I_C = 10A, I_B = 1A$) ($I_C = 20A, I_B = 2A$)	$V_{BE(sat)}$	— —	1.95 2.3	2.5 3.5	V

switching characteristics

Resistive Load						
Rise Time	$I_C = 15A, I_{B1} = .75A, I_{B2} = 1.5A$ $V_{CC} = 300V, t_p = 50 \mu sec$	t_r	—	0.3	—	μs
Storage Time		t_s	—	2.7	—	
Fall Time		t_f	—	1.15	—	
Inductive Load, Clamped						
Storage Time	$V_{CC} = 300V, L = 100 \mu H$ $I_C = 15A, I_{B1} = .75A, I_{B2} = 1.5A$	t_s	—	3.3	—	μs
Crossover Time		t_c	—	1.7	—	
Fall Time		t_f	—	0.4	—	

emitter-collector diode characteristics

Forward Voltage $I_F = 10A$ $I_F = 25A$	V_F	— —	1.9 2.8	— —	Volts
-----------------------------------------------	-------	--------	------------	--------	-------

TYPICAL CHARACTERISTICS

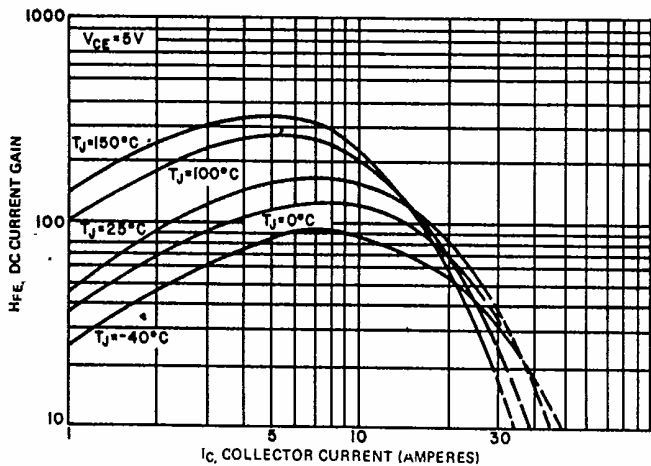

FIGURE 1. DC CURRENT GAIN ($V_{CE} = 2V$)

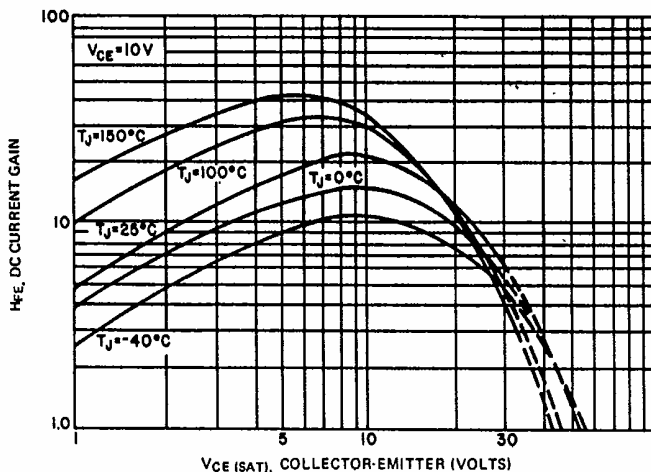

FIGURE 2. DC CURRENT GAIN ($V_{CE} = 10V$)

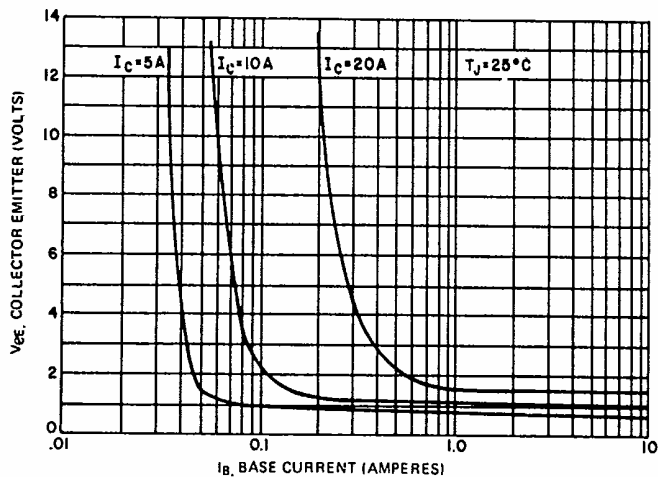

FIGURE 3. COLLECTOR SATURATION REGION

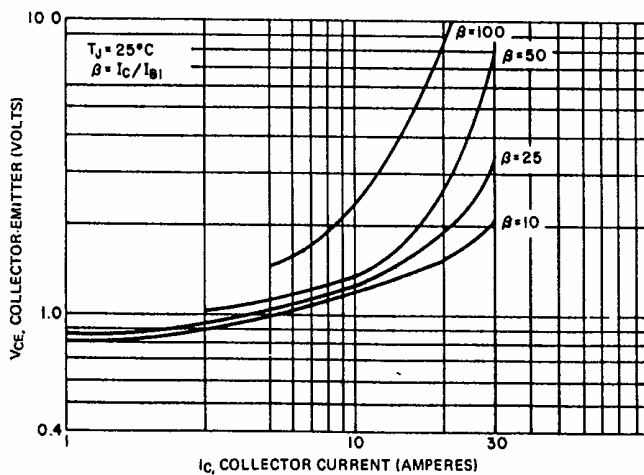

FIGURE 4. $V_{CE(SAT)}$ VS. I_C , $T_J = 25^\circ C$

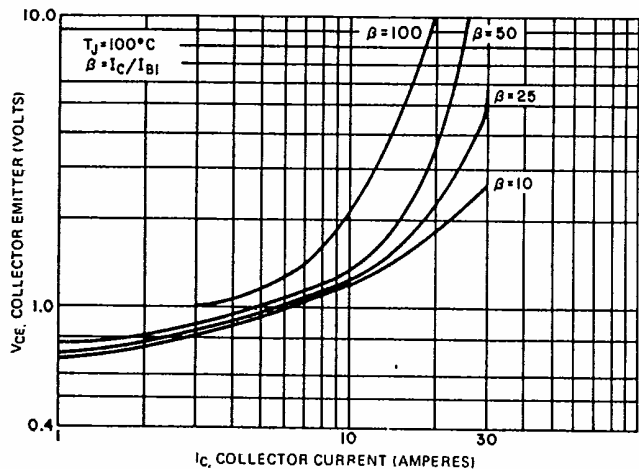

FIGURE 5. $V_{CE(SAT)}$ VS. I_C , $T_J = 100^\circ C$

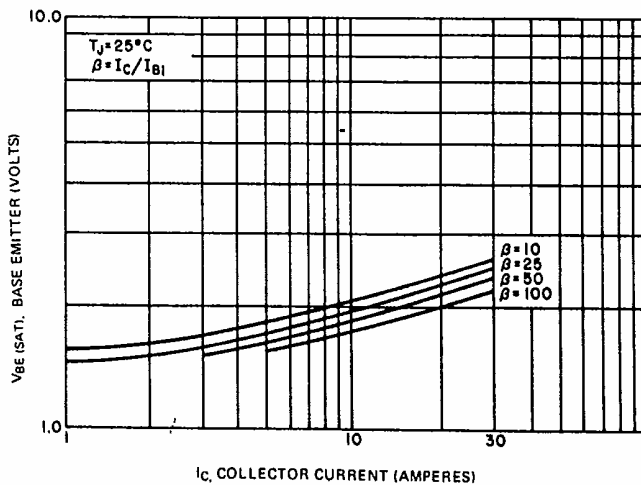

FIGURE 6. $V_{BE(SAT)}$ VS. I_C , $T_J = 25^\circ C$

TYPICAL CHARACTERISTICS

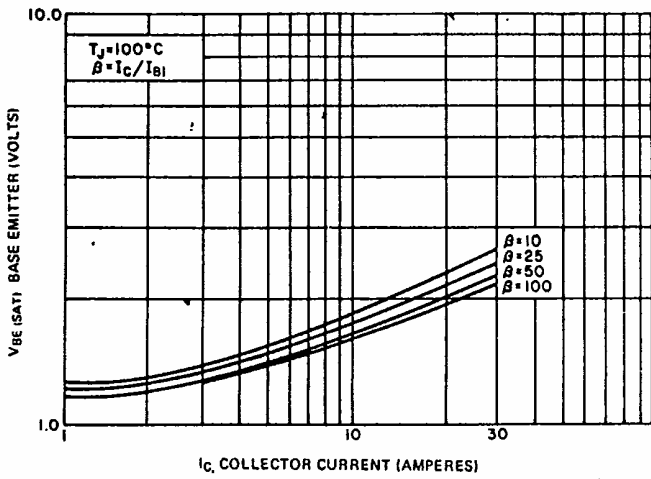

FIGURE 7. $V_{BE(SAT)}$ VS. I_C , $T_J = 100^\circ\text{C}$

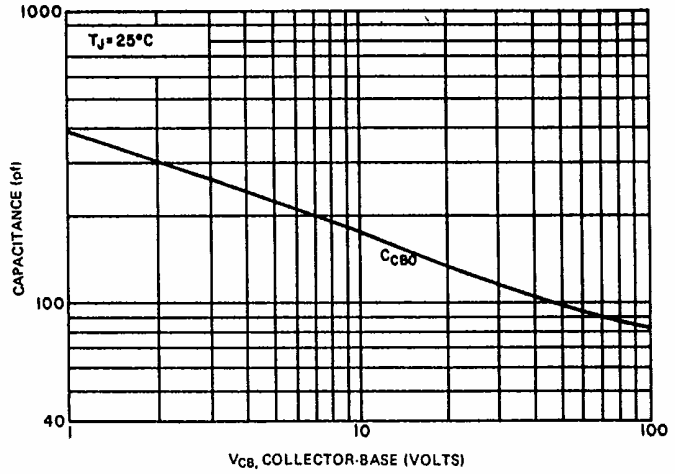

FIGURE 8. CAPACITANCE (C_{CBO})

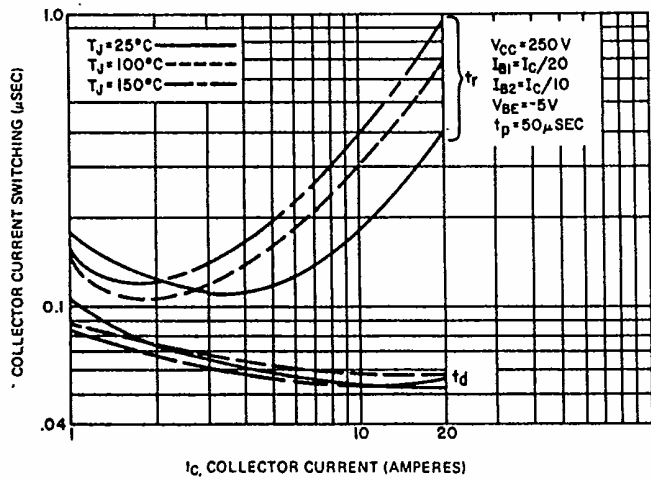

FIGURE 9. TURN-ON TIME (RESISTIVE LOAD)

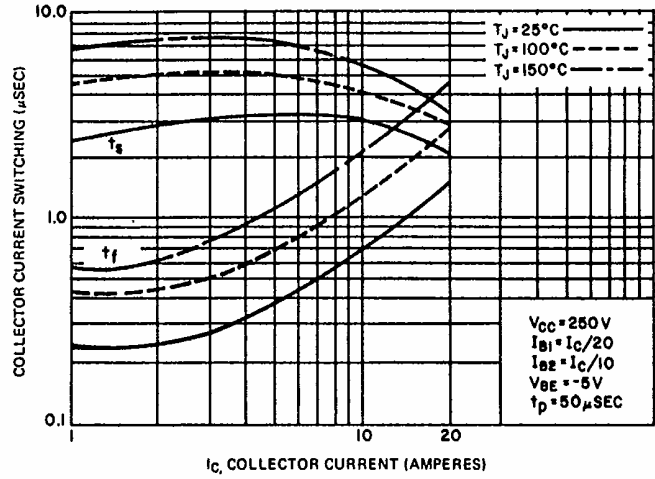

FIGURE 10. TURN-OFF TIME (RESISTIVE)

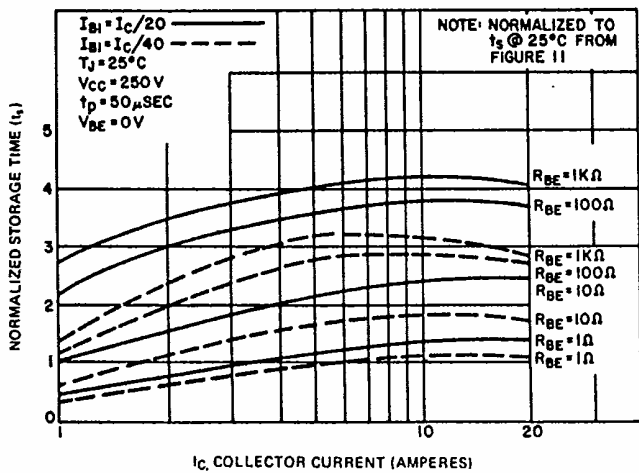

FIGURE 11. NORMALIZED RESISTIVE SWITCHING STORAGE TIME (R_{BE} VARIATIONS) VS. COLLECTOR CURRENT

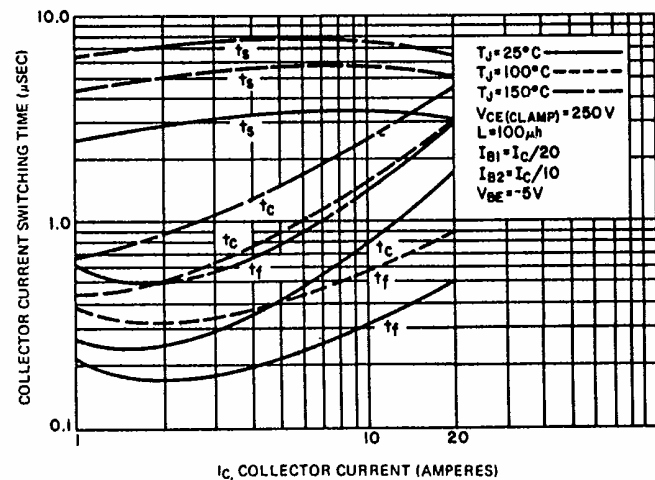

FIGURE 12. CLAMPED INDUCTIVE TURN-OFF TIME

TYPICAL CHARACTERISTICS

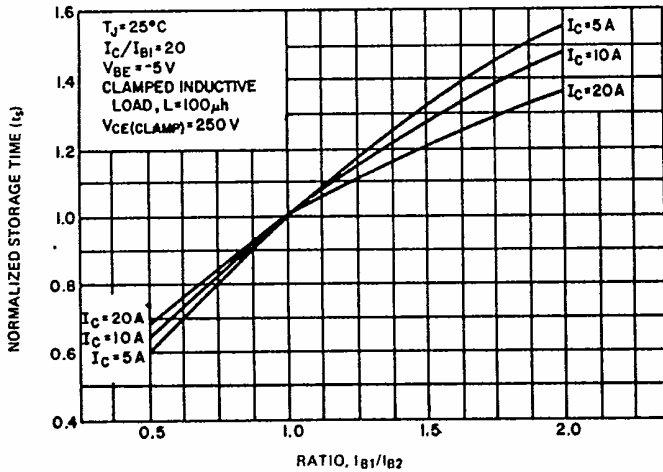

FIGURE 13. STORAGE TIME VARIATION WITH I_{B2}

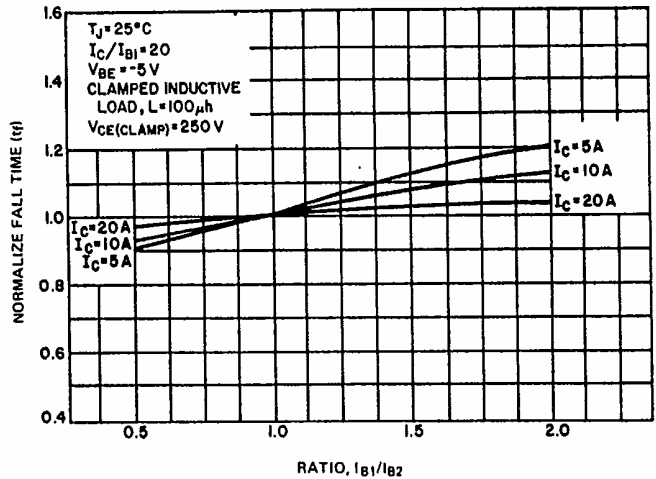

FIGURE 14. FALL TIME VARIATION WITH I_{B2}

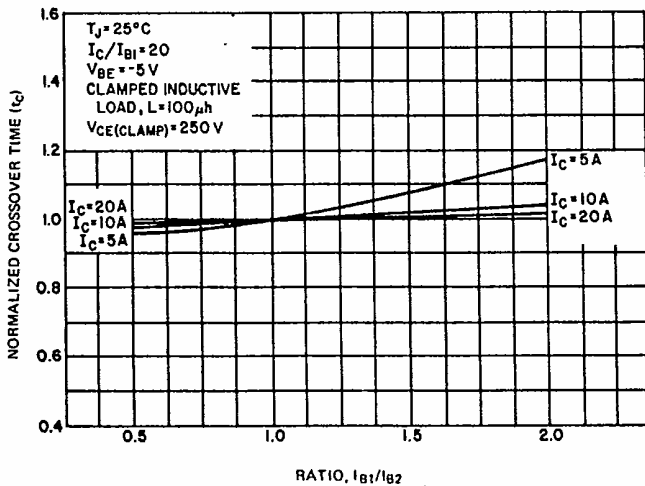

FIGURE 15. CROSS-OVER TIME VARIATION WITH I_{B2}

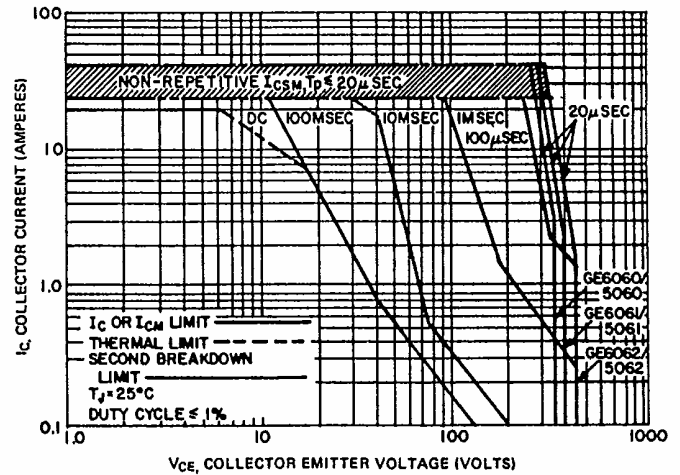

FIGURE 16. FORWARD BIAS SAFE OPERATING AREA

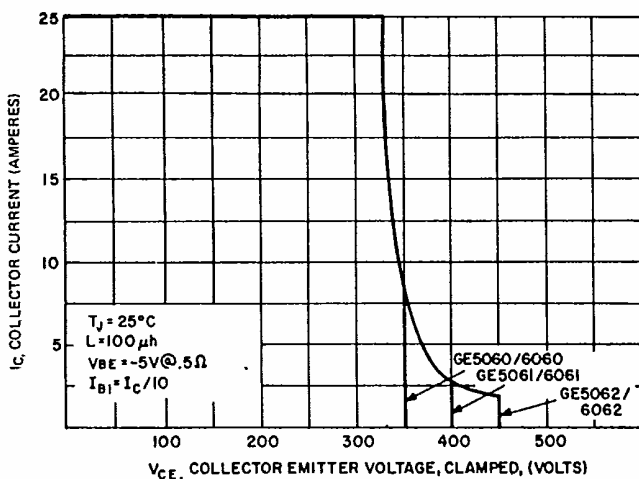

FIGURE 17. REVERSE BIAS SAFE OPERATING AREA

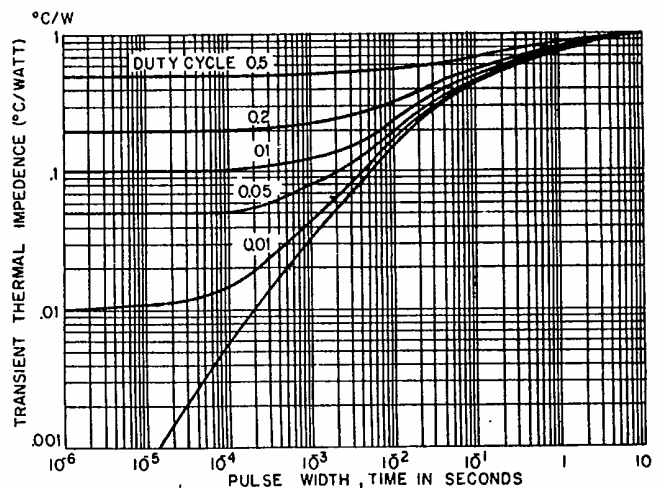

FIGURE 18. TRANSIENT THERMAL RESPONSE

TYPICAL CHARACTERISTICS

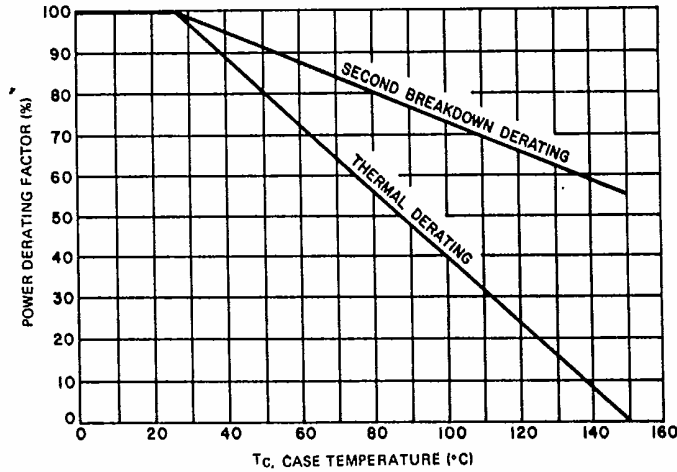

FIGURE 19. POWER DERATING

DIODE CHARACTERISTICS

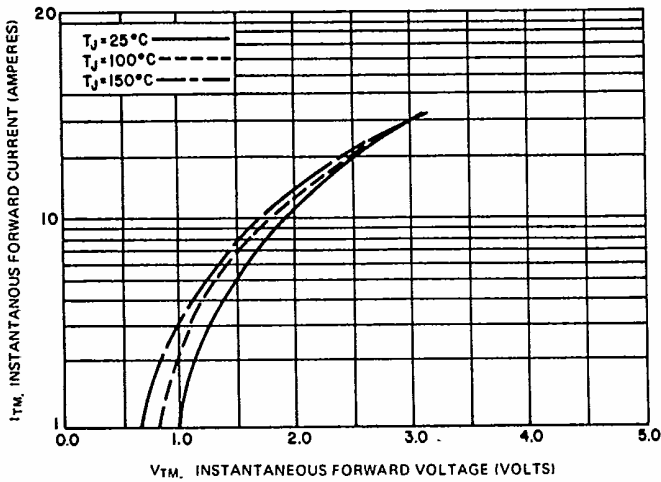

FIGURE 20. FORWARD CHARACTERISTICS

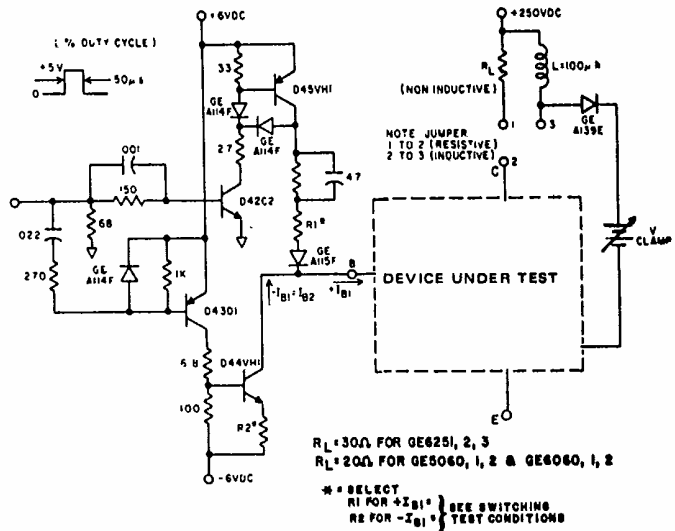

FIGURE 21. SWITCHING TIME TEST CIRCUIT

This datasheet has been downloaded from:

www.DatasheetCatalog.com

Datasheets for electronic components.



LittleDiode supplies new, hard to find or obsolete electronic components and semiconductors all over the world.

With over two million different components listed you are sure to find the part you need.

Feel free to visit us today at our online store:

LittleDiode.com

Looking forward to providing you with the best possible service.