

Digital transistors (built-in resistors)

DTD143EK / DTD143ES / DTD143EC

●Features

- 1) Built-in bias resistors enable the configuration of an inverter circuit without connecting external input resistors (see equivalent circuit).
- 2) The bias resistors consist of thin film resistors with complete isolation to allow negative biasing of the input. They also have the advantage of almost completely eliminating parasitic effects.
- 3) Only the on / off conditions need to be set for operation, making device design easy.

●Structure

NPN digital transistor
(Built-in resistor type)

●Equivalent circuit

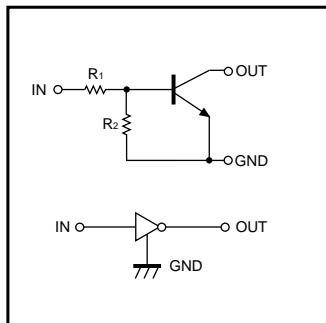

●External dimensions (Units : mm)

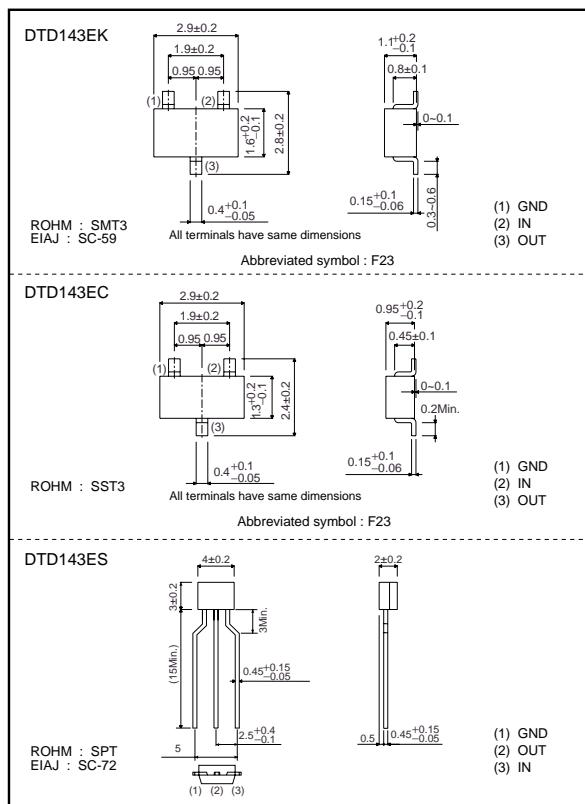

●Absolute maximum ratings (Ta=25°C)

Parameter	Symbol	Limits (DTD143E□)			Unit
		K	C	S	
Supply voltage	V _{CC}	50			V
Input voltage	V _{IN}	-10~+30			V
Output current	I _c	500			mA
Power dissipation	P _d	200	300		mW
Junction temperature	T _j	150			°C
Storage temperature	T _{stg}	-55~+150			°C

Transistors

●Electrical characteristics (Ta=25°C)

Parameter	Symbol	Min.	Typ.	Max.	Unit	Conditions
Input voltage	$V_{I(off)}$	-	-	0.5	V	$V_{CC}=5V, I_o=100\mu A$
	$V_{I(on)}$	3	-	-		$V_o=0.3V, I_o=20mA$
Output voltage	$V_{O(on)}$	-	0.1	0.3	V	$I_o / I_i=50mA / 2.5mA$
Input current	I_i	-	-	1.8	mA	$V_i=5V$
Output current	$I_o(off)$	-	-	0.5	μA	$V_{CC}=50V, V_i=0V$
DC current gain	G_i	47	-	-	-	$V_o=5V, I_o=50mA$
Input resistance	R_1	3.29	4.7	6.11	$k\Omega$	-
Resistance ratio	R_2 / R_1	0.8	1	1.2	-	-
Transition frequency	f_r	-	200	-	MHz	$V_{CE}=10V, I_E=-50mA, f=100MHz$ *

* Transition frequency of the device

●Packaging specifications

Type	Package	SMT3	SST3	SPT
		Package	SMT3	SST3
	Code	T146	T116	TP
	Basic ordering unit (pieces)	3000	3000	5000
DTD143EK		○	-	-
DTD143EC		-	○	-
DTD143ES		-	-	○

●Electrical characteristic curves

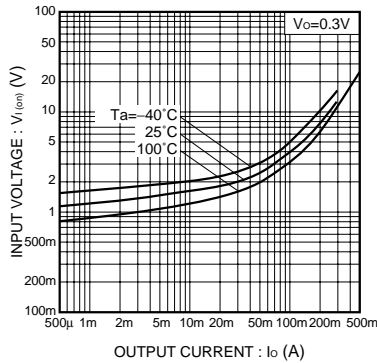

Fig.1 Input voltage vs. output current (ON characteristics)

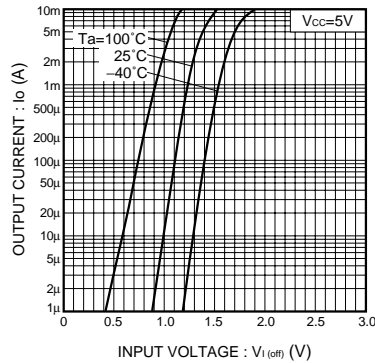

Fig.2 Output current vs. input voltage (OFF characteristics)

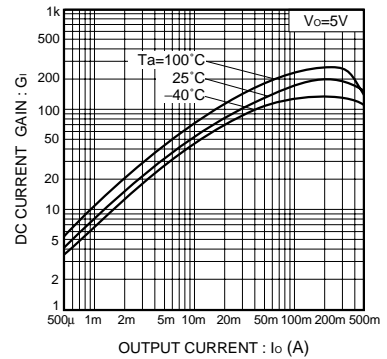

Fig.3 DC current gain vs. output current

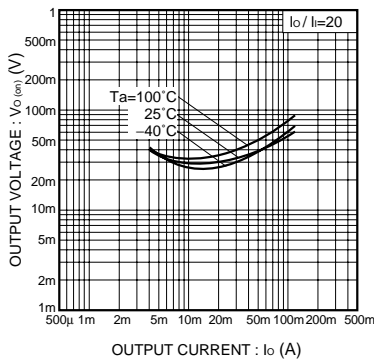

Fig.4 Output voltage vs. output current



LittleDiode supplies new, hard to find or obsolete electronic components and semiconductors all over the world.

With over two million different components listed you are sure to find the part you need.

Feel free to visit us today at our online store:

LittleDiode.com

Looking forward to providing you with the best possible service.