

Digital transistors (built-in resistor)

DTD123TK / DTD123TS

●Features

- 1) Built-in bias resistors enable the configuration of an inverter circuit without connecting external input resistors (see equivalent circuit).
- 2) The bias resistors consist of thin-film resistors with complete isolation to allow negative biasing of the input. They also have the advantage of almost completely eliminating parasitic effects.
- 3) Only the on/off conditions need to be set for operation, making device design easy.

●Structure

NPN digital transistor
(Built-in resistor type)

●External dimensions (Units: mm)

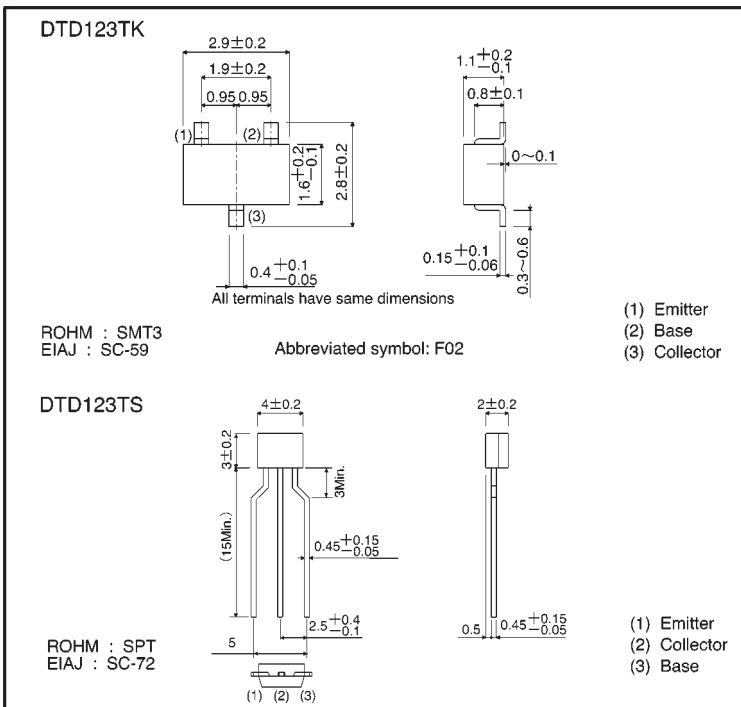

●Absolute maximum ratings (Ta = 25°C)

Parameter	Symbol	Limits(DTD123T□)		Unit
		K	S	
Collector-base voltage	V _{CBO}	50		V
Collector-emitter voltage	V _{CEO}	40		V
Emitter-base voltage	V _{EBO}	5		V
Collector current	I _C	500		mA
Collector power dissipation	P _C	200	300	mW
Junction temperature	T _j	150		°C
Storage temperature	T _{stg}	-55~+150		°C

●Equivalent circuit

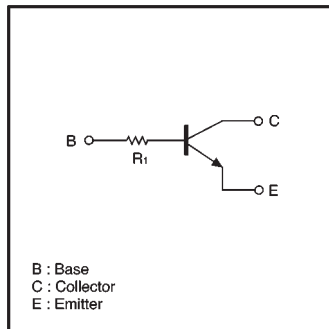

●Electrical characteristics (Ta = 25°C)

Parameter	Symbol	Min.	Typ.	Max.	Unit	Conditions
Collector-base breakdown voltage	BV_{CBO}	50	—	—	V	$I_C=50\mu A$
Collector-emitter breakdown voltage	BV_{CEO}	40	—	—	V	$I_C=1mA$
Emitter-base breakdown voltage	BV_{EBO}	5	—	—	V	$I_E=50\mu A$
Collector cutoff current	I_{CBO}	—	—	0.5	μA	$V_{CB}=50V$
Emitter cutoff current	I_{EBO}	—	—	0.5	μA	$V_{EB}=4V$
Collector-emitter saturation voltage	$V_{CE(sat)}$	—	—	0.3	V	$I_C/I_B=50m/2.5mA$
DC current transfer ratio	h_{FE}	100	250	600	—	$V_{CE}=5V, I_C=50mA$
Input resistance	R_i	1.54	2.2	2.86	k Ω	—
Transition frequency	f_T	—	200	—	MHz	$V_{CE}=10V, I_E=-50mA, f=100MHz$ *

* Transition frequency of the device

●Packaging specifications

Part No.	Package	SMT3	SPT
	Packaging type	Taping	Taping
	Code	T146	TP
	Basic ordering unit (pieces)	3000	5000
DTD123TK		○	—
DTD123TS		—	○

●Electrical characteristic curves

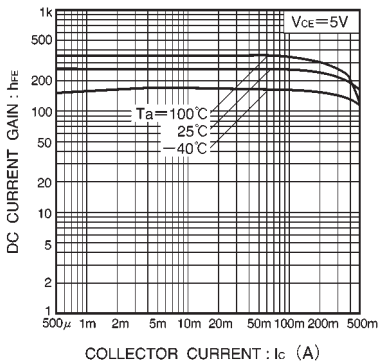

Fig.1 DC current gain vs. collector current

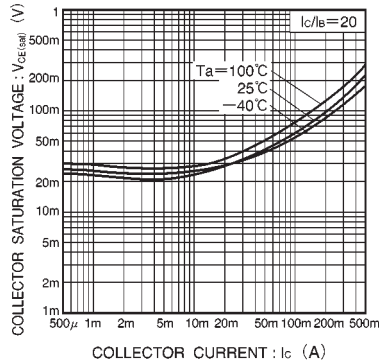

Fig.2 Collector-emitter saturation voltage vs. collector current



LittleDiode supplies new, hard to find or obsolete electronic components and semiconductors all over the world.

With over two million different components listed you are sure to find the part you need.

Feel free to visit us today at our online store:

LittleDiode.com

Looking forward to providing you with the best possible service.