

# Digital transistors (built-in resistor)

## DTC314TU / DTC314TK

### ●Features

In addition to the features of regular digital transistors,

- 1) Low saturation voltage, typically  $V_{CE(sat)}=40\text{mV}$  at  $I_C/I_B=50\text{mA}/2.5\text{mA}$ , makes these transistors ideal for muting circuits.
- 2) These transistors can be used at high current levels,  $I_C=600\text{mA}$ .

### ●Structure

NPN digital transistor  
(Built-in resistor type)

### ●Equivalent circuit

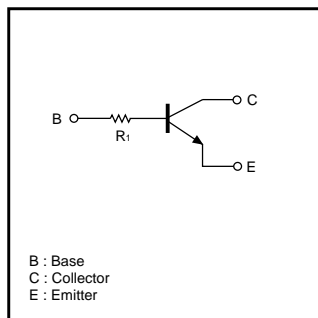

### ●External dimensions (Units : mm)

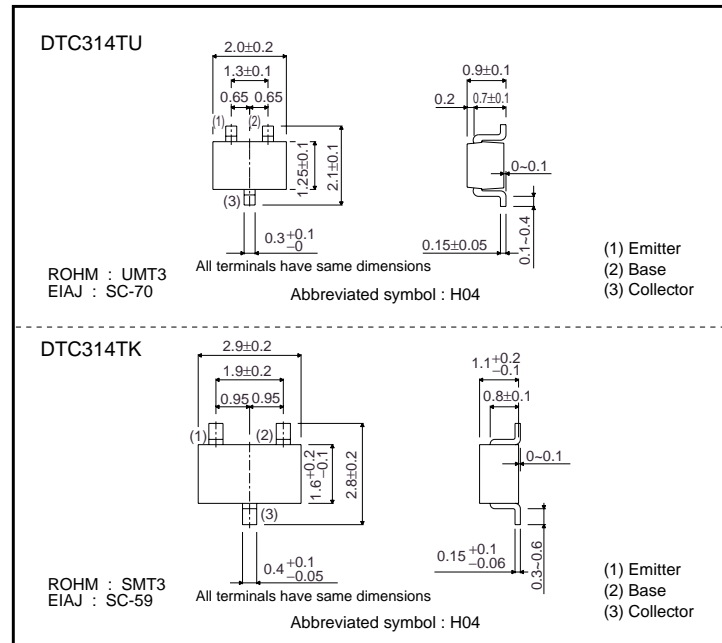

### ●Absolute maximum ratings ( $T_a=25^\circ\text{C}$ )

Parameter	Symbol	Limits(DTC314T□)		Unit
		U	K	
Collector-base voltage	$V_{CB0}$	30		V
Collector-emitter voltage	$V_{CE0}$	15		V
Emitter-base voltage	$V_{EB0}$	5		V
Collector current	$I_C$	600		mA
Collector power dissipation	$P_C$	200		mW
Junction temperature	$T_j$	150		$^\circ\text{C}$
Storage temperature	$T_{stg}$	-55~+150		$^\circ\text{C}$

Transistors

●Electrical characteristics (Ta=25°C)

Parameter	Symbol	Min.	Typ.	Max.	Unit	Conditions
Collector-base breakdown voltage	BV <sub>CBO</sub>	30	–	–	V	I <sub>c</sub> =50μA
Collector-emitter breakdown voltage	BV <sub>CEO</sub>	15	–	–	V	I <sub>c</sub> =1mA
Emitter-base breakdown voltage	BV <sub>EB0</sub>	5	–	–	V	I <sub>E</sub> =50μA
Collector cutoff current	I <sub>CBO</sub>	–	–	0.5	μA	V <sub>CB</sub> =20V
Emitter cutoff current	I <sub>EB0</sub>	–	–	0.5	μA	V <sub>EB</sub> =4V
Collector-emitter saturation voltage	V <sub>CE(sat)</sub>	–	40	80	mV	I <sub>c</sub> /I <sub>B</sub> =50mA/2.5mA
DC current transfer ratio	h <sub>FE</sub>	100	250	600	–	V <sub>CE</sub> =5V, I <sub>c</sub> =50mA
Input resistance	R <sub>i</sub>	7	10	13	kΩ	–
Transition frequency	f <sub>T</sub>	–	200	–	MHz	V <sub>CE</sub> =10V, I <sub>E</sub> =–50mA, f=100MHz *
Output "ON" resistance	R <sub>on</sub>	–	1.5	–	Ω	V <sub>i</sub> =7V, R <sub>L</sub> =1kΩ, f=1kHz

\* Transition frequency of the device

●Packaging specifications

Type	Package	UMT3	SMT3
	Packaging type	Taping	Taping
	Code	T106	T146
	Basic ordering unit (pieces)	3000	3000
DTC314TU		○	–
DTC314TK		–	○

●Electrical characteristic curves

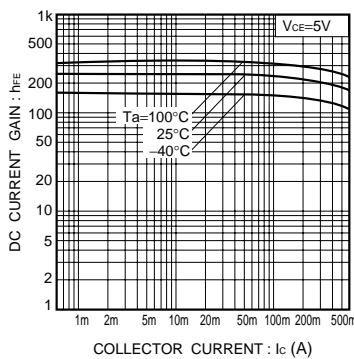

Fig.1 DC current gain vs. collector current

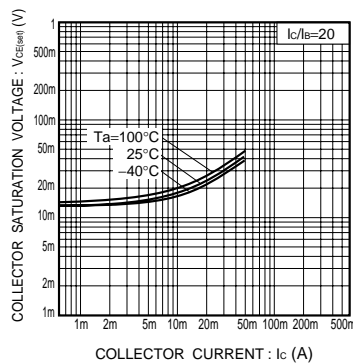

Fig.2 Collector-emitter saturation voltage vs. collector current

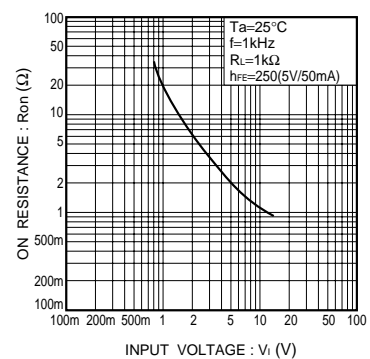

Fig.3 "ON" resistance vs. input voltage

## Transistors

●  $R_{on}$  measurement circuit

Fig.4 Output "ON" resistance ( $R_{on}$ ) measurement circuit



LittleDiode supplies new, hard to find or obsolete electronic components and semiconductors all over the world.

With over two million different components listed you are sure to find the part you need.

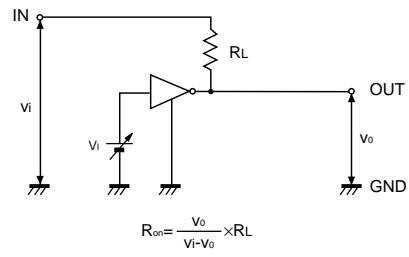
Feel free to visit us today at our online store:

[LittleDiode.com](http://LittleDiode.com)

Looking forward to providing you with the best possible service.