

DS8T26A/DS8T26AM/DS8T28/DS8T28M 4-Bit Bidirectional Bus Transceivers

General Description

The DS8T26A, DS8T28 consist of 4 pairs of TRI-STATE® logic elements configured as quad bus drivers/receivers along with separate buffered receiver enable and driver enable lines. This single IC quad transceiver design distinguishes the DS8T26A, DS8T28 from conventional multi-IC implementations. In addition, the DS8T26A, DS8T28's ultra high speed while driving heavy bus capacitance (300 pF) makes these devices particularly suitable for memory systems and bidirectional data buses.

Both the driver and receiver gates have TRI-STATE outputs and low current PNP inputs. PNP inputs reduce input loading to 200 μ A maximum.

Features

- Inverting outputs in the DS8T26A
- Non-inverting outputs in the DS8T28
- TRI-STATE outputs
- Low current PNP inputs
- Fast switching times (20 ns)
- Advanced Schottky processing
- Driver glitch free power up/down
- Non-overlapping TRI-STATE

Logic and Connection Diagrams

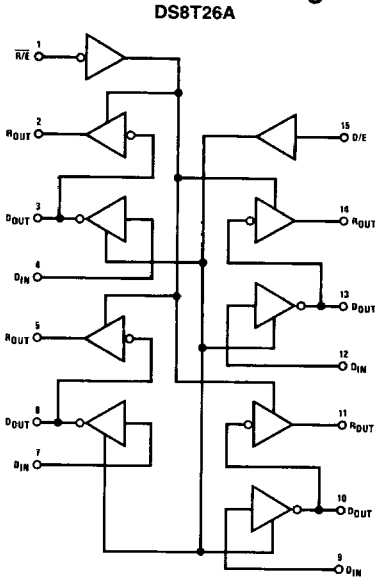

TL/F/5813-1

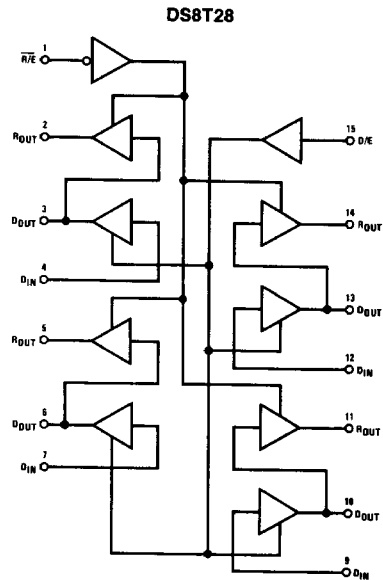

TL/F/5813-2

Dual-In-Line Package

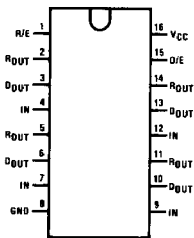

Top View

TL/F/5813-3

**Order Number DS8T26AJ, DS8T26AMJ, DS8T28J,
DS8T28MJ, DS8T26AN or DS8T28N**
See NS Package Number J16A or N16A

Absolute Maximum Ratings (Note 1)

If Military/Aerospace specified devices are required, contact the National Semiconductor Sales Office/Distributors for availability and specifications.

All Output and Supply Voltages	-0.5V to +7V
All Input Voltages	-1V to +5.5V
Output Currents	±150 mA
Storage Temperature	-65°C to +150°C
Maximum Power Dissipation* at 25°C	
Cavity Package	1509 mW
Molded Package	1476 mW
Lead Temperature (Soldering, 4 seconds)	260°C

*Derate cavity package 10.1 mW/°C above 25°C; derate molded package 11.8 mW/°C above 25°C.

Recommended Operating Conditions

	Min	Max	Units
Supply Voltage (V _{CC})			
DS8T26A, DS8T28	4.75	5.25	V
DS8T26AM, DS8T28M	4.5	5.5	V
Temperature (T _A)			
DS8T26A, DS8T28	0	70	°C
DS8T26AM, DS8T28M	-55	+125	°C

Electrical Characteristics (Notes 2, 3 and 4)

Symbol	Parameter	Conditions	Min	Typ	Max	Units
DRIVER						
I _{IL}	Low Level Input Current	V _{IN} = 0.4V			-200	μA
I _{IL}	Low Level Input Current (Disabled)	V _{IN} = 0.4V			-25	μA
I _{IH}	High Level Input Current (D _{IN} , D _E)	V _{IN} = V _{CC} Max			25	μA
V _{OL}	Low Level Output Voltage (Pins 3, 6, 10, 13)	I _{OUT} = 48 mA			0.5	V
V _{OH}	High Level Output Voltage, (Pins 3, 6, 10, 13)	I _{OUT} = -10 mA	2.4			V
I _{OS}	Short-Circuit Output Current, (Pins 3, 6, 10, 13)	V _{OUT} = 0V, V _{CC} = V _{CC} Max	-50		-150	mA
RECEIVER						
I _{IL}	Low Level Input Current	V _{IN} = 0.4V			-200	μA
I _{IH}	High Level Input Current (R _E)	V _{IN} = V _{CC} Max			25	μA
V _{OL}	Low Level Output Voltage	I _{OUT} = 20 mA			0.5	V
V _{OH}	High Level Output Voltage, (Pins 2, 5, 11, 14)	I _{OUT} = -100 μA	3.5			V
		I _{OUT} = -2 mA	2.4			V
I _{OS}	Short-Circuit Output Current, (Pins 2, 5, 11, 14)	V _{OUT} = 0V, V _{CC} = V _{CC} Max	-30		-75	mA
BOTH DRIVER AND RECEIVER						
V _{TL}	Low Level Input Threshold Voltage	V _{CC} = Min, V _{IN} = 0.8V, I _{OL} = Max	0.85			V
V _{TH}	High Level Input Threshold Voltage	V _{CC} = Max, V _{IN} = 0.8V, I _{OH} = Max			2	V
I _{OZ}	Low Level Output OFF Leakage Current	V _{OUT} = 0.5V			-100	μA
I _{OZ}	High Level Output OFF Leakage Current	V _{OUT} = 2.4V			100	μA
V _I	Input Clamp Voltage	I _{IN} = -12 mA			-1.0	V

Switching Characteristics $V_{CC} = 5V, T_A = 25^\circ C$

Symbol	Parameter	Conditions	DS8T26A Max	DS8T28 Max	Units
Propagation Delay					
t_{ON}	D_{OUT} to R_{OUT} , (Figure 1)	$C_L = 30\text{ pF}$	14	17	ns
t_{OFF}	D_{OUT} to R_{OUT} , (Figure 1)		14	17	ns
t_{ON}	D_{IN} to D_{OUT} , (Figure 2)	$C_L = 300\text{ pF}$	14	17	ns
t_{OFF}	D_{IN} to D_{OUT} , (Figure 2)		14	17	ns
Data Enable to Data Output					
t_{PZL}	High Z to 0, (Figure 3)	$C_L = 300\text{ pF}$	25	28	ns
t_{PLZ}	0 to High Z, (Figure 3)		20	23	ns
Receiver Enable to Receiver Output					
t_{PZL}	High Z to 0, (Figure 4)	$C_L = 30\text{ pF}$	20	23	ns
t_{PLZ}	0 to High Z, (Figure 4)		15	18	ns

AC Test Circuits and Switching Time Waveforms

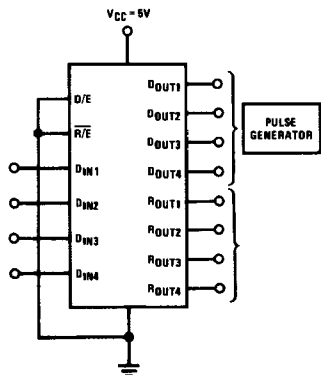

TL/F/5813-4

FIGURE 1. Propagation Delay (D_{OUT} to R_{OUT})

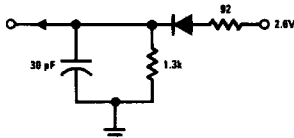

TL/F/5813-5

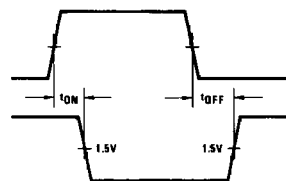

TL/F/5813-6

Input pulse:
 $t_r = t_f = 5\text{ ns}$ (10% to 90%)
 Freq = 10 MHz (50% duty cycle)
 Amplitude = 2.6V

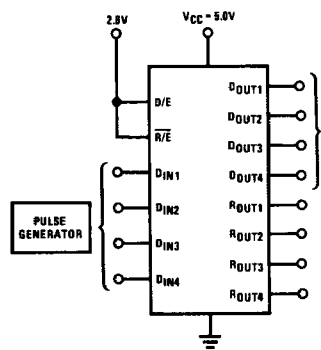

TL/F/5813-7

FIGURE 2. Propagation Delay (D_{IN} to D_{OUT})

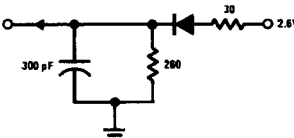

TL/F/5813-8

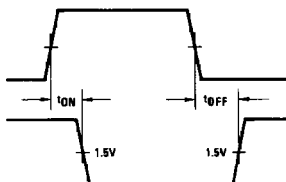

TL/F/5813-9

Input pulse:
 $t_r = t_f = 5\text{ ns}$ (10% to 90%)
 Freq = 10 MHz (50% duty cycle)
 Amplitude = 2.6V

AC Test Circuits and Switching Time Waveforms (Continued)

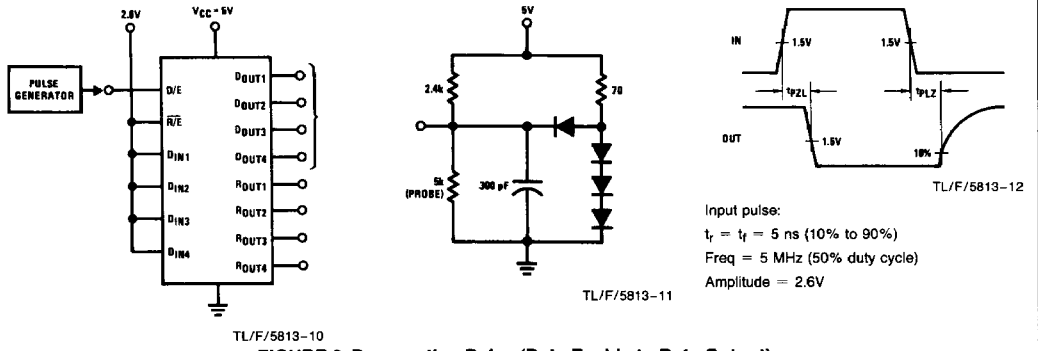

FIGURE 3. Propagation Delay (Data Enable to Data Output)

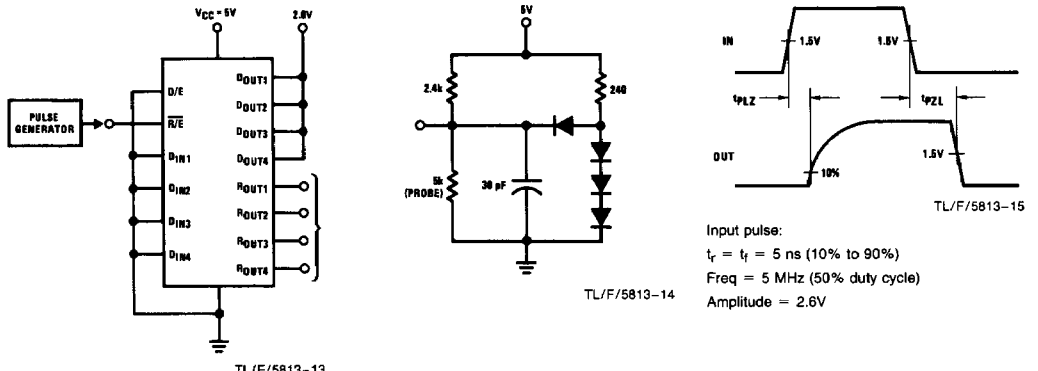

FIGURE 4. Propagation Delay (Receive/Enable to Receive Output)

This datasheet has been downloaded from:

www.DatasheetCatalog.com

Datasheets for electronic components.

National Semiconductor was acquired by Texas Instruments.

http://www.ti.com/corp/docs/investor_relations/pr_09_23_2011_national_semiconductor.html

This file is the datasheet for the following electronic components:

DS8T28 - <http://www.ti.com/product/ds8t28?HQS=TI-null-null-dscatalog-df-pf-null-ww>



LittleDiode supplies new, hard to find or obsolete electronic components and semiconductors all over the world.

With over two million different components listed you are sure to find the part you need.

Feel free to visit us today at our online store:

LittleDiode.com

Looking forward to providing you with the best possible service.