

DS75491 MOS-to-LED Quad Segment Driver DS75492 MOS-to-LED Hex Digit Driver

General Description

The DS75491 and DS75492 are interface circuits designed to be used in conjunction with MOS integrated circuits and common-cathode LEDs in serially addressed multi-digit displays. The number of drivers required for this time-multiplexed system is minimized as a result of the segment-address-and-digit-scan method of LED drive.

Features

- 50 mA source or sink capability per driver (DS75491)
- 250 mA sink capability per driver (DS75492)
- MOS compatibility (low input current)
- Low standby power
- High-gain Darlington circuits

Schematic and Connection Diagrams

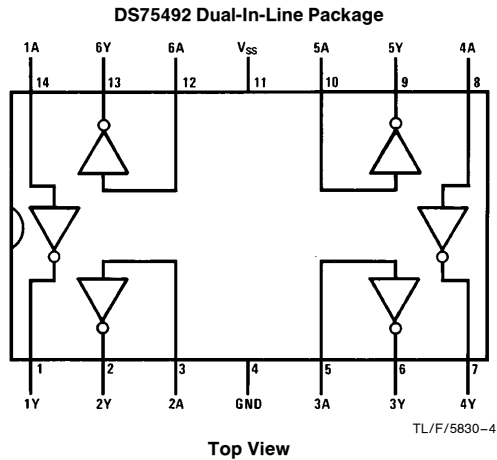
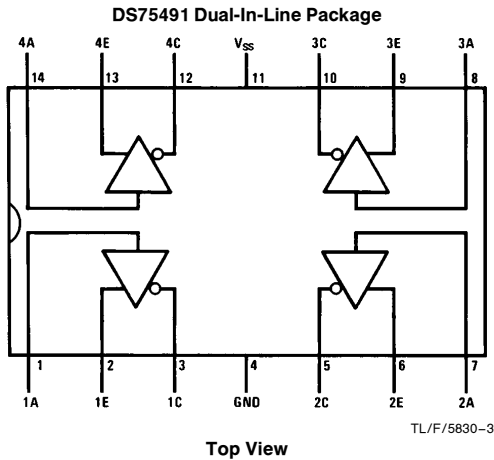
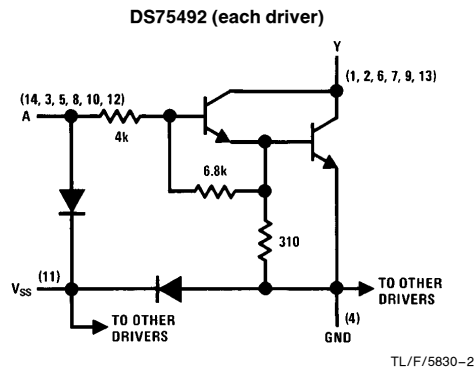
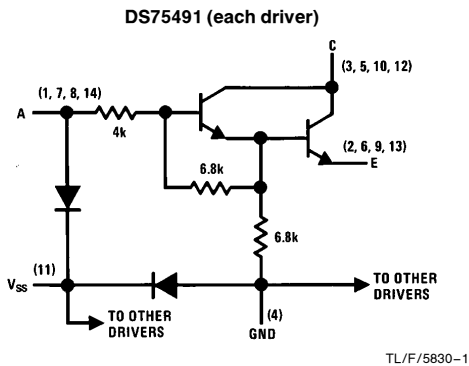

Order Number DS75491N, DS75492M or DS75492N
See NS Package Number M14A or N14A

DS75491 MOS-to-LED Quad Segment Driver DS75492 MOS-to-LED Hex Digit Driver

Absolute Maximum Ratings (Note 1)

If Military/Aerospace specified devices are required, please contact the National Semiconductor Sales Office/Distributors for availability and specifications.

	DS75491	DS75492
Input Voltage Range (Note 4)	-5V to V_{SS}	
Collector Output Voltage (Note 5)	10V	10V
Collector Output to Input Voltage	10V	10V
Emitter to Ground Voltage ($V_I \geq 5V$)	10V	
Emitter to Input Voltage	5V	
Voltage at V_{SS} Terminal with Respect to any Other Device Terminal	10V	10V
Collector Output Current		
Each Collector Output	50 mA	250 mA
All Collector Outputs	200 mA	600 mA

Continuous Total Dissipation	DS75491	DS75492
	600 mW	600 mW
Operating Temperature Range	0°C to +70°C	
Storage Temperature Range	-65°C to +150°C	
Lead Temp. (Soldering, 10 sec)	300°C	300°C
Maximum Power Dissipation at 25°C		
Molded Package	1207 mW*	1280 mW†
*Derate molded package 9.66 mW/°C above 25°C.		
†Derate molded package 10.24 mW/°C above 25°C.		

Electrical Characteristics $V_{SS} = 10V$ (Notes 2 and 3)

Symbol	Parameter	Conditions	Min	Typ	Max	Units
DS75491						
$V_{CE\ ON}$	"ON" State Collector Emitter Voltage	Input = 8.5V through 1 k Ω , $V_E = 5V$, $I_C = 50\ mA$				
		$T_A = 25^\circ C$		0.9	1.2	V
		$T_A = 0-70^\circ C$			1.5	V
$I_{C\ OFF}$	"OFF" State Collector Current	$V_C = 10V$, $V_E = 0V$			100	μA
		$I_{IN} = 40\ \mu A$			100	μA
		$V_{IN} = 0.7V$			100	μA
I_I	Input Current at Maximum Input Voltage	$V_{IN} = 10V$, $V_E = 0V$, $I_C = 20\ mA$		2.2	3.3	mA
I_E	Emitter Reverse Current	$V_{IN} = 0V$, $V_E = 5V$, $I_C = 0\ mA$			100	μA
I_{SS}	Current Into V_{SS} Terminal				1	mA
DS75492						
V_{OL}	Low Level Output Voltage	Input = 6.5V through 1 k Ω , $I_{OUT} = 250\ mA$				
		$T_A = 25^\circ C$		0.9	1.2	V
		$T_A = 0-70^\circ C$			1.5	V
I_{OH}	High Level Output Current	$V_{OH} = 10V$			200	μA
		$I_{IN} = 40\ \mu A$			200	μA
		$V_{IN} = 0.5V$			200	μA
I_I	Input Current at Maximum Input Voltage	$V_{IN} = 10V$, $I_{OL} = 20\ mA$		2.2	3.3	mA
I_{SS}	Current Into V_{SS} Terminal				1	mA

Switching Characteristics $V_{SS} = 7.5V$, $T_A = 25^\circ C$

Symbol	Parameter	Conditions	Min	Typ	Max	Units
DS75491						
t_{PLH}	Propagation Delay Time, Low-to-High Level Output (Collector)	$V_{IH} = 4.5V$, $V_E = 0V$, $R_L = 200\ \Omega$, $C_L = 15\ pF$		100		ns
t_{PHL}	Propagation Delay Time, High-to-Low Level Output (Collector)			20		ns
DS75492						
t_{PLH}	Propagation Delay Time, Low-to-High Level Output	$V_{IH} = 7.5V$, $R_L = 39\ \Omega$, $C_L = 15\ pF$		300		ns
t_{PHL}	Propagation Delay Time, High-to-Low Level Output			30		ns

Note 1: "Absolute Maximum Ratings" are those values beyond which the safety of the device cannot be guaranteed. Except for "Operating Temperature Range" they are not meant to imply that the devices should be operated at these limits. The table of "Electrical Characteristics" provides conditions for actual device operation.

Note 2: Unless otherwise specified min/max limits apply across the 0°C to +70°C temperature range for the DS75491 and DS75492.

Note 3: All currents into device pins shown as positive, out of device pins as negative, all voltages referenced to ground unless otherwise noted. All values shown as max or min on absolute value basis.

Note 4: The input is the only device terminal which may be negative with respect to ground.

Note 5: Voltage values are with respect to network ground terminal unless otherwise noted.

AC Test Circuits and Switching Time Waveforms

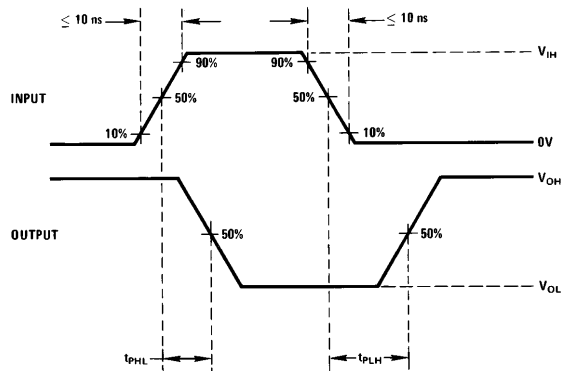
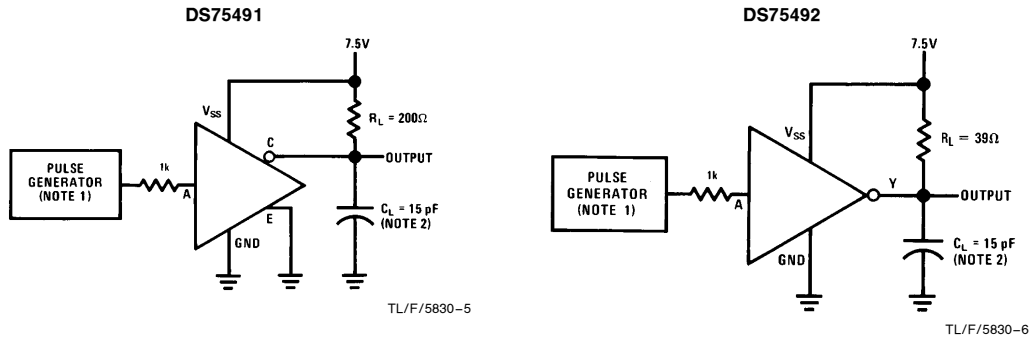

Note 1: The pulse generator has the following characteristics: $Z_{OUT} = 50\Omega$, $PRR = 100\text{ kHz}$, $t_W = 1\ \mu\text{s}$.

Note 2: C_L includes probe and jig capacitance.

TL/F/5830-7

Physical Dimensions inches (millimeters)

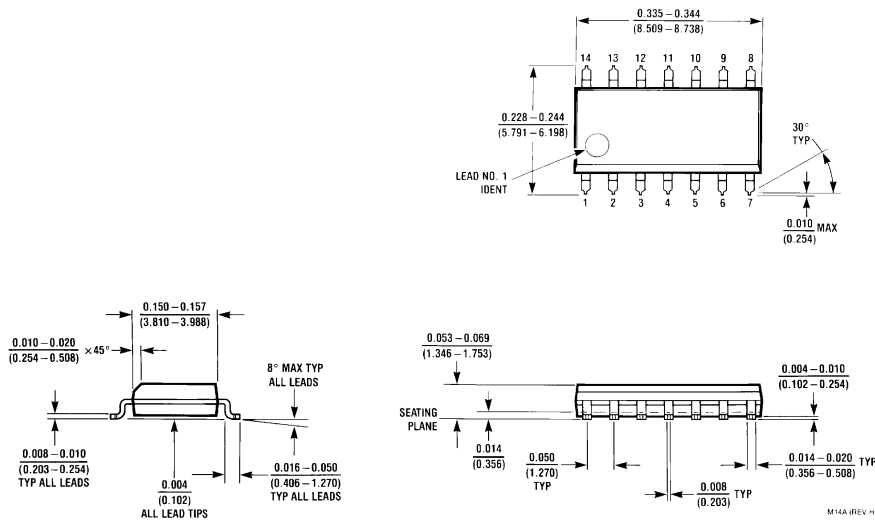

14-Lead (0.150" Wide) Molded Small Outline Package, JEDEC
Order Number DS75492M
NS Package Number M14A

Physical Dimensions inches (millimeters) (Continued)

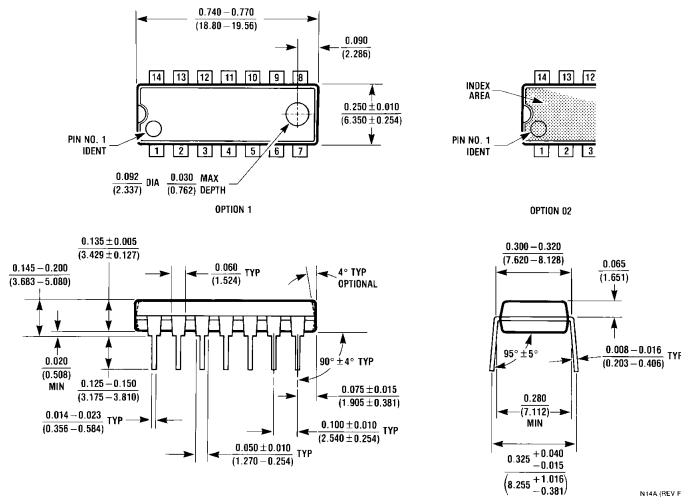

Molded Dual-In-Line Package (N)
Order Number DS75491N or DS75492N
NS Package Number N14A

LIFE SUPPORT POLICY

NATIONAL'S PRODUCTS ARE NOT AUTHORIZED FOR USE AS CRITICAL COMPONENTS IN LIFE SUPPORT DEVICES OR SYSTEMS WITHOUT THE EXPRESS WRITTEN APPROVAL OF THE PRESIDENT OF NATIONAL SEMICONDUCTOR CORPORATION. As used herein:

1. Life support devices or systems are devices or systems which, (a) are intended for surgical implant into the body, or (b) support or sustain life, and whose failure to perform, when properly used in accordance with instructions for use provided in the labeling, can be reasonably expected to result in a significant injury to the user.
2. A critical component is any component of a life support device or system whose failure to perform can be reasonably expected to cause the failure of the life support device or system, or to affect its safety or effectiveness.



National Semiconductor Corporation
 1111 West Bardin Road
 Arlington, TX 76017
 Tel: 1(800) 272-9959
 Fax: 1(800) 737-7018

National Semiconductor Europe
 Fax: (+49) 0-180-530 85 86
 Email: cnjwge@tevm2.nsc.com
 Deutsch Tel: (+49) 0-180-530 85 85
 English Tel: (+49) 0-180-532 78 32
 Français Tel: (+49) 0-180-532 93 58
 Italiano Tel: (+49) 0-180-534 16 80

National Semiconductor Hong Kong Ltd.
 19th Floor, Straight Block,
 Ocean Centre, 5 Canton Rd.
 Tsimshatsui, Kowloon
 Hong Kong
 Tel: (852) 2737-1600
 Fax: (852) 2736-9960

National Semiconductor Japan Ltd.
 Tel: 81-043-299-2309
 Fax: 81-043-299-2408

National does not assume any responsibility for use of any circuitry described, no circuit patent licenses are implied and National reserves the right at any time without notice to change said circuitry and specifications.

National Semiconductor was acquired by Texas Instruments.

http://www.ti.com/corp/docs/investor_relations/pr_09_23_2011_national_semiconductor.html

This file is the datasheet for the following electronic components:

DS75491 - <http://www.ti.com/product/ds75491?HQS=TI-null-null-dscatalog-df-pf-null-ww>

DS75492 - <http://www.ti.com/product/ds75492?HQS=TI-null-null-dscatalog-df-pf-null-ww>



LittleDiode supplies new, hard to find or obsolete electronic components and semiconductors all over the world.

With over two million different components listed you are sure to find the part you need.

Feel free to visit us today at our online store:

LittleDiode.com

Looking forward to providing you with the best possible service.