

DS75129 Eight-Channel Line Receivers

General Description

The DS75129 is an eight-channel line receiver designed to satisfy the requirements of the input-output interface specification for IBM 360/370. The device features common strobes for each group of four receivers. The DS75129 has an active-low strobe. Special low-power design and Schottky-diode-clamped transistors allow low supply-current requirements while maintaining fast switching speeds and high-current TTL outputs. The DS75129 is characterized for operation from 0°C to 70°C.

Features

- Meets IBM 360/370 I/O specification
- Input resistance—7 kΩ to 20 kΩ
- Output compatible with TTL
- Schottky-clamped transistors
- Operates from a single 5V supply
- High speed—low propagation delay
- Ratio specification— t_{PLH}/t_{PL}
- Common strobe for each group of four receivers
- DS75129 strobe—active-low

Connection Diagram

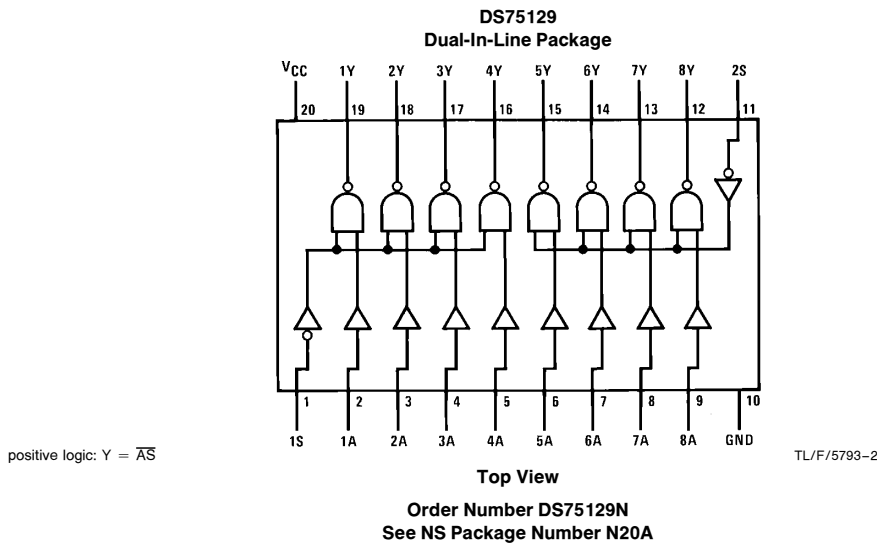

Absolute Maximum Ratings (Note 1)

If Military/Aerospace specified devices are required, please contact the National Semiconductor Sales Office/Distributors for availability and specifications.

Supply Voltage, V_{CC}	7V
Input Voltage Range	-0.15V to 7V
Strobe Input Voltage	7V
Maximum Power Dissipation* at 25°C (Note 2)	
Molded Package	1687 mW
Operating Free-Air Temperature Range	0°C to +70°C
Storage Temperature Range	-65°C to +150°C

*Derate molded package 13.5 mW/°C above 25°C.

Lead Temperature 260°C
 $\frac{1}{16}$ Inch from Case for 4 Seconds: N Package

Recommended Operating Conditions

	Min	Typ	Max	Units
Supply Voltage, V_{CC}	4.5	5.0	5.5	V
High-Level Output Current, I_{OH}			-0.4	mA
Low-Level Output Current, I_{OL}			16	mA
Operating Free-Air Temperature, T_A	0		70	°C

Electrical Characteristics over recommended operating free-air temperature range (Note 3)

Symbol	Parameter	Conditions	Min	Typ (Note 5)	Max	Units
V_{IH}	High-Level Input Voltage	A	1.7			V
		S	2			
V_{IL}	Low-Level Input Voltage	A			0.7	V
		S			0.7	
V_{OH}	High-Level Output Voltage	$V_{CC} = 4.5V, V_{IL} = 0.7V, I_{OH} = 0.4 mA$	2.4	3.1		V
V_{OL}	Low-Level Output Voltage	$V_{CC} = 4.5V, V_{IH} = 1.7V, I_{OL} = 16 mA$		0.4	0.5	V
V_I	Input Clamp Voltage	S $V_{CC} = 4.5V, I_I = -18 mA$			-1.5	V
I_{IH}	High-Level Input Current	A $V_{CC} = 5.5V, V_I = 3.11V$		0.3	0.42	mA
		S $V_{CC} = 5.5V, V_I = 2.7V$			20	μA
I_{IL}	Low-Level Input Current	A $V_{CC} = 5.5V, V_I = 0.15V$			-0.24	mA
		S $V_{CC} = 5.5V, V_I = 0.4V$			-0.4	
I_{OS}	Short-Circuit Output Current (Note 4)	$V_{CC} = 5.5V, V_O = 0V$	-18		-60	mA
r_I	Input Resistance	$V_{CC} = 4.5V, 0V, \text{ or Open}, \Delta V = 0.15V \text{ to } 4.15V$	7		20	k Ω
I_{CC}	Supply Current	$V_{CC} = 5.5V, \text{ Strobe at } 0.4V, \text{ All A Inputs at } 0.7V$		19	31	mA
		$V_{CC} = 5.5V, \text{ Strobe at } 0.4V, \text{ All A Inputs at } 4V$		32	53	

Note 1: "Absolute Maximum Ratings" are those values beyond which the safety of the device cannot be guaranteed. Except for "Operating Temperature Range" they are not meant to imply that the devices should be operated at these limits. The table of "Electrical Characteristics" provides conditions for actual device operation.

Note 2: For operation above 25°C free-air temperature, refer to Thermal Ratings for ICs, in App Note AN-336.

Note 3: All currents into device pins shown as positive, out of device pins as negative, all voltages referenced to ground unless otherwise noted. All values shown as max or min on absolute value basis.

Note 4: Only one output should be shorted at a time.

Note 5: All typical values are at $V_{CC} = 5V, T_A = 25^\circ C$.

Switching Characteristics $V_{CC} = 5V, T_A = 25^\circ C$

Symbol	Parameter	Conditions	Min	Typ	Max	Units	
t_{PLH}	Propagation Delay Time, Low-to-High-Level Output	$R_L = 400\Omega,$ $C_L = 50\text{ pF},$ See Figure 1	7	14	25	ns	
t_{PHL}	Propagation Delay Time, High-to-Low-Level Output		10	18	30	ns	
t_{PLH}	Propagation Delay Time, Low-to-High-Level Output			20	35	ns	
t_{PHL}	Propagation Delay Time, High-to-Low-Level Output			16	30	ns	
t_{PLH}	Ratio of Propagation Delay Times		A	0.5	0.8	1.3	
t_{PHL}							
t_{TLH}	Transition Time, Low-to-High-Level Output			1	7	12	ns
t_{THL}	Transition Time, High-to-Low-Level Output			1	3	12	ns

Schematic Diagram (each receiver)

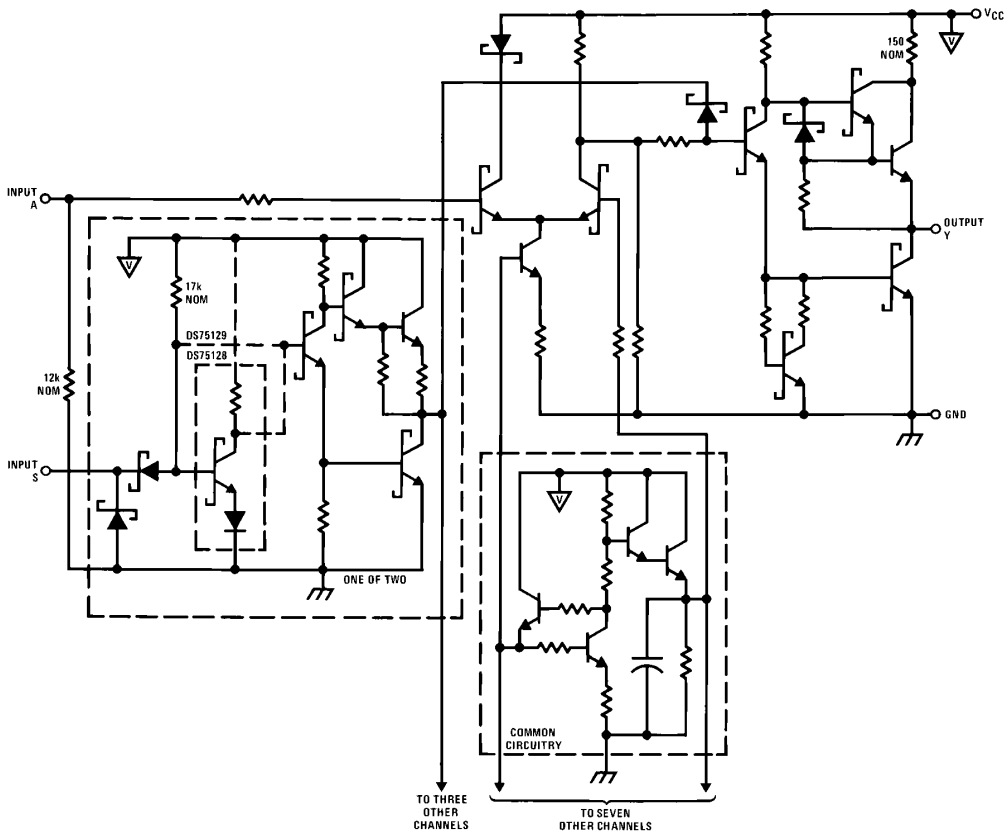

TL/F/5793-3

AC Test Circuit and Switching Time Waveforms

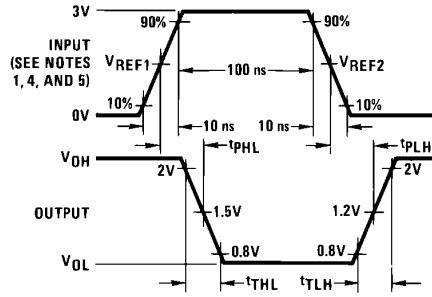
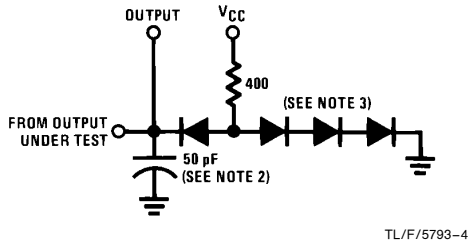

Note 1: Input pulses are supplied by a generator having the following characteristics: $Z_O = 50\Omega$, PRR = 5 MHz.

Note 2: Includes probe and jig capacitance.

Note 3: All diodes are 1N3064 or equivalent.

Note 4: The strobe inputs of DS75129 are in-phase with the output.

Note 5: $V_{REF1} = 0.7V$ and $V_{REF2} = 1.7V$ for testing data (A) inputs, $V_{REF1} = V_{REF2} = 1.3V$ for strobe inputs.

FIGURE 1

Typical Characteristics

Voltage Transfer Characteristics From A Inputs

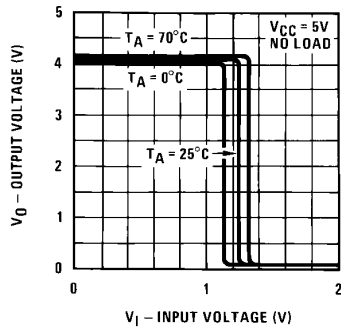

Voltage Transfer Characteristics From A Inputs

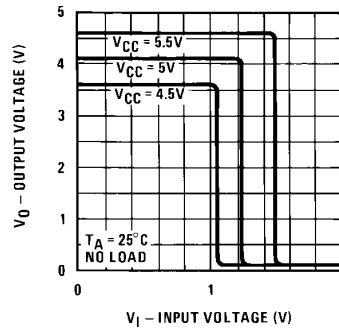

Input Current vs Input Voltage, A Inputs

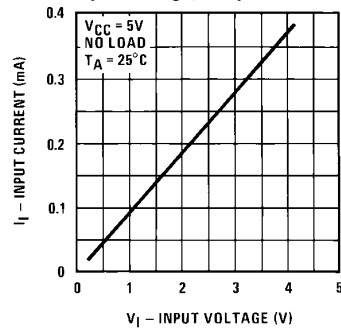

Low-Level Output Voltage vs Output Current

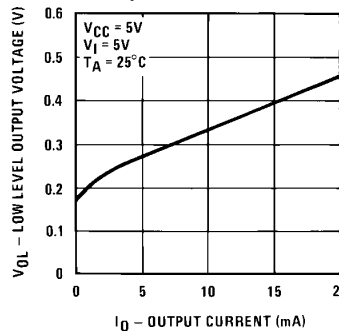

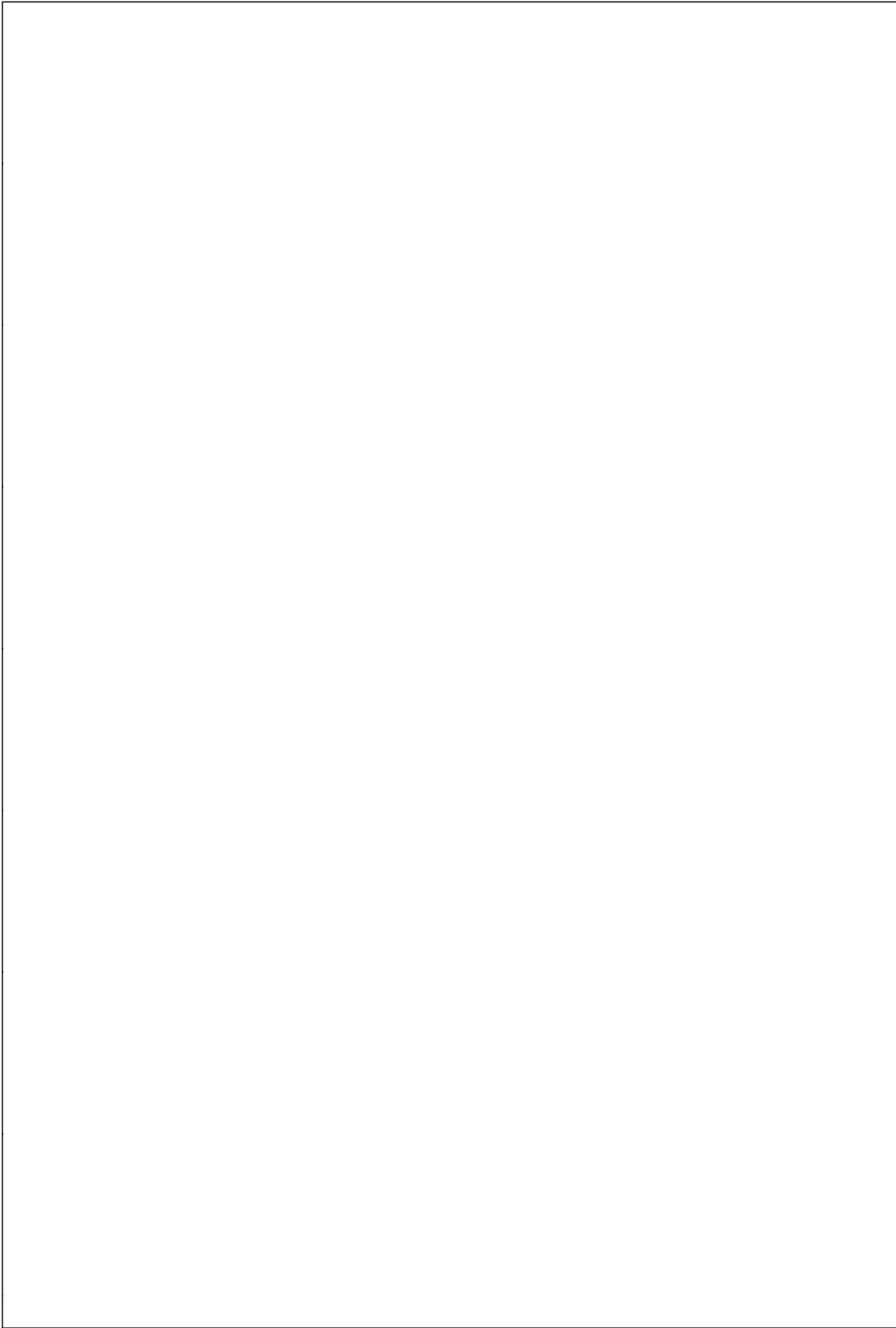

Physical Dimensions inches (millimeters)

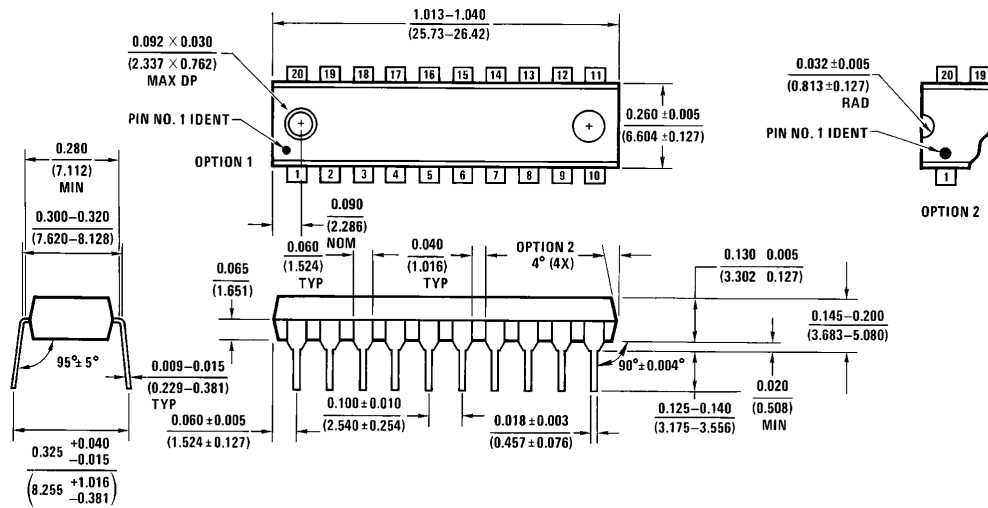

Molded Dual-In-Line Package (N)
Order Number DS75129N
NS Package Number N20A

N20A (REV G)

LIFE SUPPORT POLICY

NATIONAL'S PRODUCTS ARE NOT AUTHORIZED FOR USE AS CRITICAL COMPONENTS IN LIFE SUPPORT DEVICES OR SYSTEMS WITHOUT THE EXPRESS WRITTEN APPROVAL OF THE PRESIDENT OF NATIONAL SEMICONDUCTOR CORPORATION. As used herein:

1. Life support devices or systems are devices or systems which, (a) are intended for surgical implant into the body, or (b) support or sustain life, and whose failure to perform, when properly used in accordance with instructions for use provided in the labeling, can be reasonably expected to result in a significant injury to the user.
2. A critical component is any component of a life support device or system whose failure to perform can be reasonably expected to cause the failure of the life support device or system, or to affect its safety or effectiveness.



National Semiconductor Corporation
 1111 West Bardin Road
 Arlington, TX 76017
 Tel: (800) 272-9959
 Fax: (1800) 737-7018

<http://www.national.com>

National Semiconductor Europe

Fax: +49 (0) 180-530 85 86
 Email: europe.support@nsc.com
 Deutsch Tel: +49 (0) 180-530 85 85
 English Tel: +49 (0) 180-532 78 32
 Français Tel: +49 (0) 180-532 93 58
 Italiano Tel: +49 (0) 180-534 16 80

National Semiconductor Hong Kong Ltd.

19th Floor, Straight Block,
 Ocean Centre, 5 Canton Rd.
 Tsimshatsui, Kowloon
 Hong Kong
 Tel: (852) 2737-1600
 Fax: (852) 2736-9960

National Semiconductor Japan Ltd.

Tel: 81-043-299-2308
 Fax: 81-043-299-2408

National does not assume any responsibility for use of any circuitry described, no circuit patent licenses are implied and National reserves the right at any time without notice to change said circuitry and specifications.

National Semiconductor was acquired by Texas Instruments.

http://www.ti.com/corp/docs/investor_relations/pr_09_23_2011_national_semiconductor.html

This file is the datasheet for the following electronic components:

DS75129 - <http://www.ti.com/product/ds75129?HQS=TI-null-null-dscatalog-df-pf-null-ww>



LittleDiode supplies new, hard to find or obsolete electronic components and semiconductors all over the world.

With over two million different components listed you are sure to find the part you need.

Feel free to visit us today at our online store:

LittleDiode.com

Looking forward to providing you with the best possible service.