

DS75115/DS9615 Dual Differential Line Receiver

General Description

The DS75115/DS9615 is a dual differential line receiver designed to sense differential signals from data transmission lines. Designed for operation over military and commercial temperature ranges, the DS75115/DS9615 can typically receive ± 500 mV differential data with ± 15 V common-mode noise. Outputs are open-collector and give TTL compatible signals which are a function of the polarity of the differential input signal. Active output pull-ups are also available, offering the option of an active TTL pull-up through an external connection.

Response time may be controlled with the use of an external capacitor. Each channel may be independently controlled and optional input termination resistors are also available.

Features

- Single 5V supply
- High common-mode voltage range
- Each channel individually strobed
- Independent response time control
- Uncommitted collector or active pull-up option
- TTL compatible output
- Optional 130Ω termination resistors
- Direct replacement for 9615

Connection Diagram

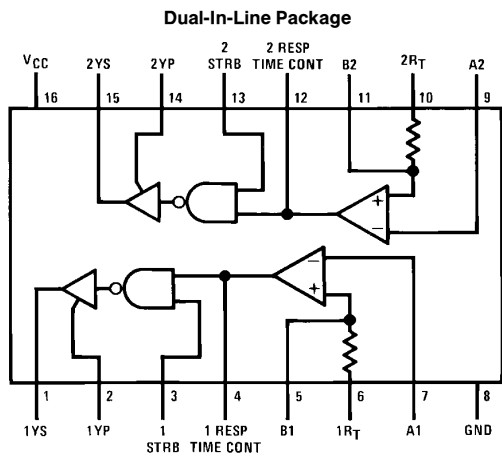

Function Table

Strobe	Diff. Input	Output
L	X	H
H	L	H
H	H	L

H = $V_I \geq V_{IH \text{ min}}$ or V_{ID} more positive than $V_{TH \text{ max}}$

L = $V_I \leq V_{IL \text{ max}}$ or V_{ID} more negative than $V_{TL \text{ max}}$

X = irrelevant

Top View

Order Number DS75115N
See NS Package Number N16A

For Complete Military 883 Specifications, See RETS Datasheet.
Order Number DS9615MJ/883, DS9615ME/883

TL/F/5787-1

Absolute Maximum Ratings (Note 1)

If Military/Aerospace specified devices are required, please contact the National Semiconductor Sales Office/Distributors for availability and specifications.

Supply Voltage, V_{CC} (Note 1)	7V
Input Voltage at A, B and R_T Inputs	$\pm 25V$
Input Voltage at Strobe Input	5.5V
Off-State Voltage Applied to Open-Collector Outputs	14V
Maximum Power Dissipation* at 25°C	
Cavity Package	1433 mW
Molded Package	1362 mW
Operating Free-Air Temperature Range	
DS9615M	-55°C to +125°C
DS57115	0°C to +70°C

Storage Temperature Range	-65°C to +150°C
Lead Temperature	
($1/16$ inch from case for 4 seconds)	260°C

*Derate cavity package 9.6 mW/°C above 25°C; derate molded package 10.9 mW/°C above 25°C.

Operating Conditions

	Min	Max	Units
Supply Voltage, (V_{CC})			
DS9615M	4.5	5.5	V
DS75115	4.75	5.25	V
High Level Output Current (I_{OH})		-5	mA
Low Level Output Current (I_{OL})		15	mA
Operating Temperature (T_A)			
DS9615M	-55	125	°C
DS75115	0	70	°C

Electrical Characteristics (Notes 2, 3 and 5)

Symbol	Parameter	Conditions	DS75115			Units
			Min	Typ	Max	
V_{TH}	Differential Input High-Threshold Voltage	$V_O = 0.4V, I_{OL} = 15\text{ mA}, V_{IC} = 0V$		200	500	mV
V_{TL}	Differential Input Low-Threshold Voltage	$V_O = 2.4V, I_{OH} = -5\text{ mA}, V_{IC} = 0V$		-200	-500	mV
V_{ICR}	Common-Mode Input Voltage Range	$V_{ID} = \pm 1V$	15 to -15	24 to -19		V
$V_{IH(STROBE)}$	High-Level Strobe Input Voltage		2.4			V
$V_{IL(STROBE)}$	Low-Level Strobe Input Voltage				0.4	V
V_{OH}	High Level Output Voltage	$V_{CC} = \text{Min}, V_{ID} = -0.5V, I_{OH} = -5\text{ mA}$	$T_A = \text{Min}$ 2.4	$T_A = 25^\circ\text{C}$ 2.4	$T_A = \text{Max}$ 2.4	V
V_{OL}	Low Level Output Voltage	$V_{CC} = \text{Min}, V_{ID} = 0.5V, I_{OL} = 15\text{ mA}$		0.22	0.45	V
I_{IL}	Low Level Input Current	$V_{CC} = \text{Max}, V_I = 0.4V, \text{Other Input at } 5.5V$	$T_A = \text{Min}$ $T_A = 25^\circ\text{C}$ $T_A = \text{Max}$		-0.9 -0.7 -0.7	mA
I_{SH}	High Level Strobe Current	$V_{CC} = \text{Min}, V_{ID} = -0.5V, V_{STROBE} = 4.5V$	$T_A = 25^\circ\text{C}$ $T_A = \text{Max}$	0.5	5 10	μA
I_{SL}	Low Level Strobe Current	$V_{CC} = \text{Max}, V_{ID} = 0.5V, V_{STROBE} = 0.4V$	$T_A = 25^\circ\text{C}$	-1.15	-2.4	mA
I_4, I_{12}	Response Time Control Current (Pin 4 or Pin 12)	$V_{CC} = \text{Max}, V_{ID} = 0.5V, V_{RC} = 0V$	$T_A = 25^\circ\text{C}$	-1.2	-3.4	mA
$I_{O(OFF)}$	Off-State Open-Collector Output Current	$V_{CC} = \text{Min}, V_{OH} = 12V, V_{ID} = -4.5V$	$T_A = 25^\circ\text{C}$ $T_A = \text{Max}$			μA
		$V_{CC} = \text{Min}, V_{OH} = 5.25V, V_{ID} = -4.75V$	$T_A = 25^\circ\text{C}$ $T_A = \text{Max}$		100 200	

Electrical Characteristics (Notes 2, 3 and 5) (Continued)

Symbol	Parameter	Conditions	DS75115			Units
			Min	Typ	Max	
R_T	Line Terminating Resistance	$V_{CC} = 5V$ $T_A = 25^\circ C$	74	130	179	Ω
I_{OS}	Short-Circuit Output Current	$V_{CC} = \text{Max}$, $V_O = 0V$, $V_{ID} = -0.5V$, (Note 4) $T_A = 25^\circ C$	-14	-40	-100	mA
I_{CC}	Supply Current (Both Receivers)	$V_{CC} = \text{Max}$, $V_{ID} = 0.5V$, $V_{IC} = 0V$ $T_A = 25^\circ C$		32	50	mA

Note 1: "Absolute Maximum Ratings" are those values beyond which the safety of the device cannot be guaranteed. Except for "Operating Temperature Range" they are not meant to imply that the devices should be operated at these limits. The table of "Electrical Characteristics" provides conditions for the actual device operation.

Note 2: Unless otherwise specified min/max limits apply across the $-55^\circ C$ to $+125^\circ C$ temperature range for the DS9615M and across the $0^\circ C$ to $+70^\circ C$ range for the DS75115. All typical values are for $T_A = 25^\circ C$, $V_{CC} = 5V$ and $V_{CM} = 0V$.

Note 3: All currents into device pins shown as positive, out of device pins as negative, all voltages referenced to ground unless otherwise noted. All values shown as max or min on absolute value basis.

Note 4: Only one output at a time should be shorted.

Note 5: Unless otherwise noted, $V_{STROBE} = 2.4V$. All parameters with the exception of off-state open-collector output current are measured with the active pull-up connected to the sink output.

Switching Characteristics $V_{CC} = 5V$, $C_L = 30 pF$, $T_A = 25^\circ C$

Symbol	Parameter	Conditions	DS75115			Units
			Min	Typ	Max	
t_{PLH}	Propagation Delay Time, Low-to-High Level Output	$R_L = 3.9 k\Omega$, (Figure 1)		18	75	ns
t_{PHL}	Propagation Delay Time, High-to-Low Level Output	$R_L = 390\Omega$, (Figure 1)		20	75	ns

Schematic Diagram

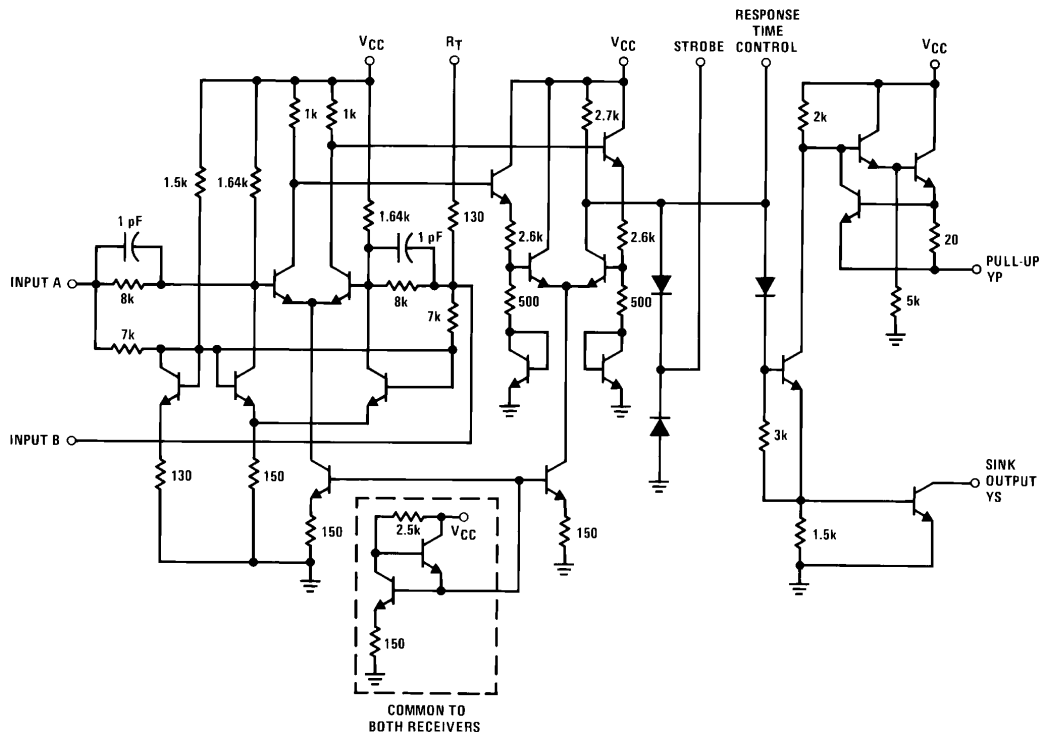

TL/F/5787-2

Typical Performance Characteristics (Note 3)

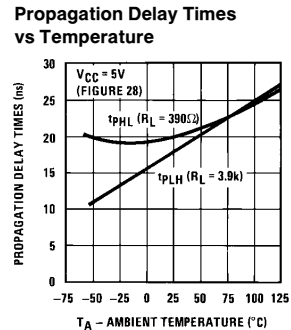
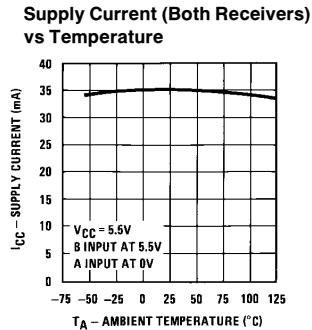
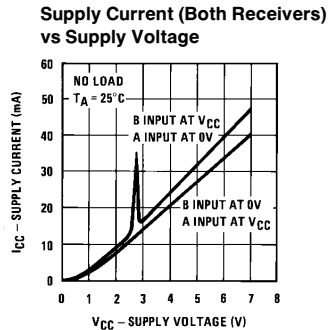
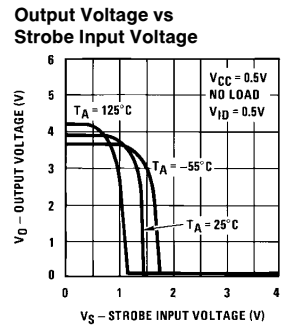
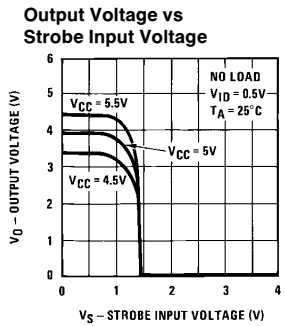
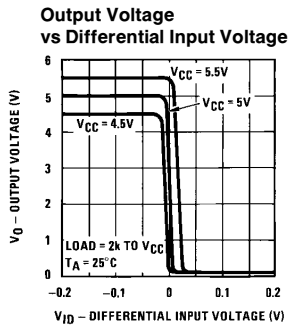
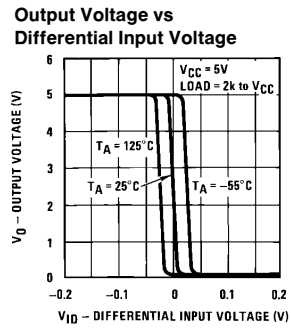
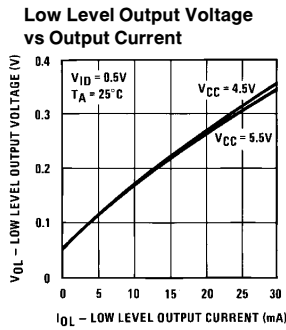
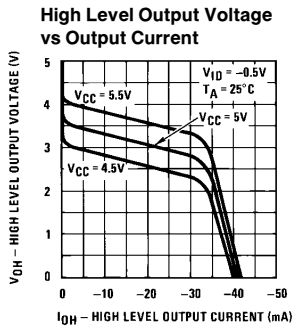
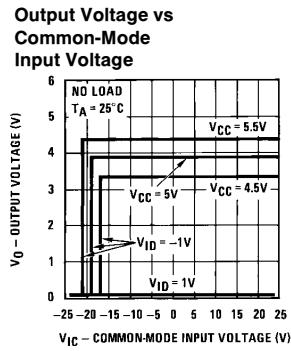
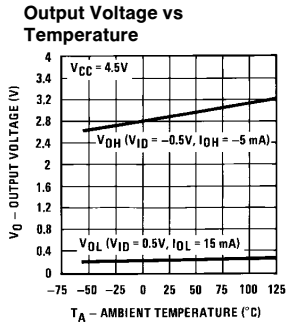
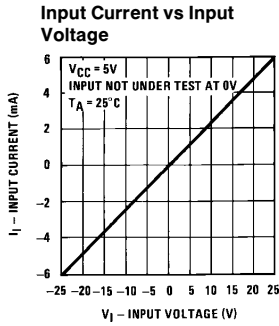

Frequency Response Control

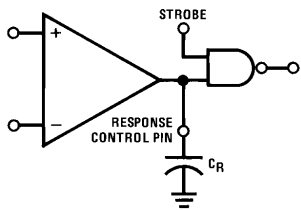

TL/F/5787-5

Note: C_R (response control) > 0.01 μF may cause slowing of rise and fall times of the output.

Frequency Response as a Function of Capacitance

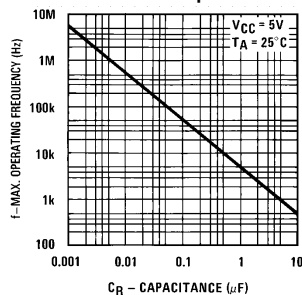

TL/F/5787-6

AC Test Circuit and Switching Time Waveforms

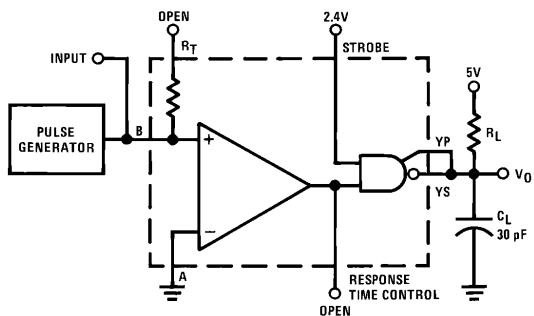

TL/F/5787-7

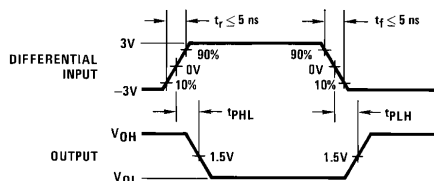

TL/F/5787-8

FIGURE 1. Propagation Delay Time (Notes 1, 2)

Note 1: The pulse generator has the following characteristics: $Z_{OUT} = 50\Omega$, $PRR = 500 \text{ kHz}/t_w = 100 \text{ ns}$

Note 2: C_L includes probe and test fixture capacitance

Typical Application

Basic Party-Line or Data-Bus Differential Data Transmission

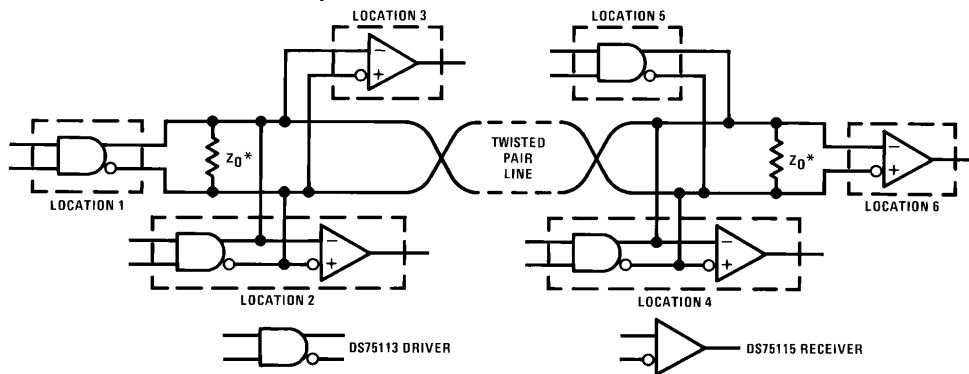

* Z_0 is internal to the DS9615/DS75115

A capacitor may be connected in series with Z_0 to reduce power dissipation.

TL/F/5787-3

Physical Dimensions inches (millimeters)

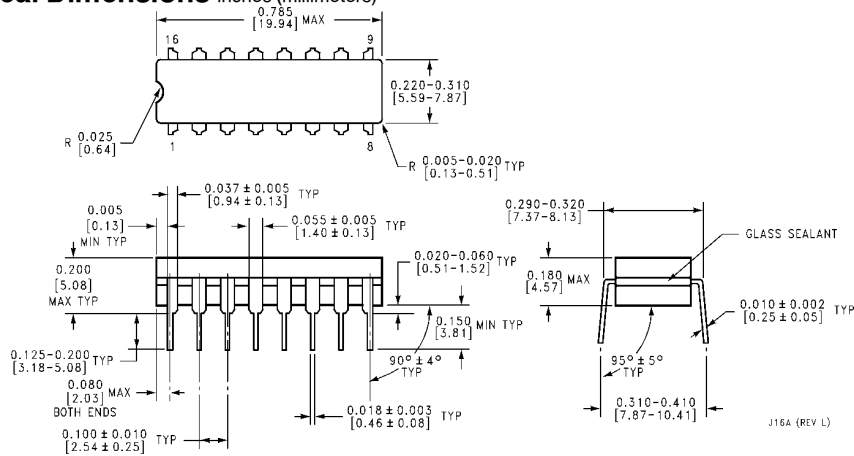

Ceramic Dual-In-Line Package (J)
Order Number DS55115J or DS75115J
NS Package Number J16A

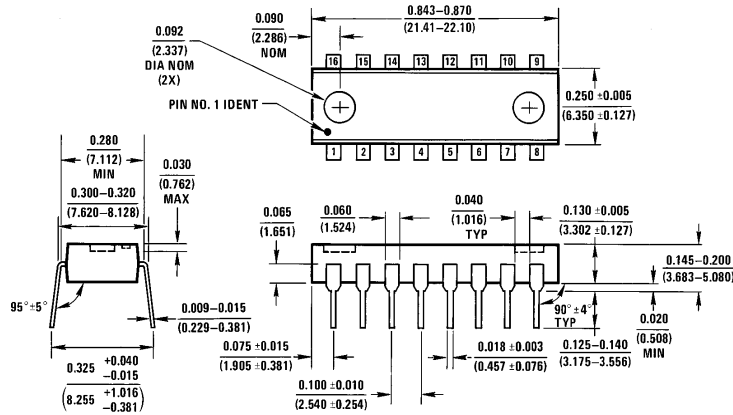

Molded Dual-In-Line Package (N)
Order Number DS75115N
NS Package Number N16A

LIFE SUPPORT POLICY

NATIONAL'S PRODUCTS ARE NOT AUTHORIZED FOR USE AS CRITICAL COMPONENTS IN LIFE SUPPORT DEVICES OR SYSTEMS WITHOUT THE EXPRESS WRITTEN APPROVAL OF THE PRESIDENT OF NATIONAL SEMICONDUCTOR CORPORATION. As used herein:

1. Life support devices or systems are devices or systems which, (a) are intended for surgical implant into the body, or (b) support or sustain life, and whose failure to perform, when properly used in accordance with instructions for use provided in the labeling, can be reasonably expected to result in a significant injury to the user.
2. A critical component is any component of a life support device or system whose failure to perform can be reasonably expected to cause the failure of the life support device or system, or to affect its safety or effectiveness.

 <p>National Semiconductor Corporation 1111 West Bardin Road Arlington, TX 76017 Tel: (800) 272-9959 Fax: (800) 737-7018 http://www.national.com</p>	<p>National Semiconductor Europe Fax: +49 (0) 180-530 85 86 Email: europe.support@nsc.com Deutsch Tel: +49 (0) 180-530 85 85 English Tel: +49 (0) 180-532 78 32 Français Tel: +49 (0) 180-532 93 58 Italiano Tel: +49 (0) 180-534 16 80</p>	<p>National Semiconductor Hong Kong Ltd. 19th Floor, Straight Block, Ocean Centre, 5 Canton Rd. Tsimshatsui, Kowloon Hong Kong Tel: (852) 2737-1600 Fax: (852) 2736-9960</p>	<p>National Semiconductor Japan Ltd. Tel: 81-043-299-2308 Fax: 81-043-299-2408</p>
---	--	---	---

National does not assume any responsibility for use of any circuitry described, no circuit patent licenses are implied and National reserves the right at any time without notice to change said circuitry and specifications.

National Semiconductor was acquired by Texas Instruments.

http://www.ti.com/corp/docs/investor_relations/pr_09_23_2011_national_semiconductor.html

This file is the datasheet for the following electronic components:

DS55115 - <http://www.ti.com/product/ds55115?HQS=TI-null-null-dscatalog-df-pf-null-ww>

DS75115 - <http://www.ti.com/product/ds75115?HQS=TI-null-null-dscatalog-df-pf-null-ww>



LittleDiode supplies new, hard to find or obsolete electronic components and semiconductors all over the world.

With over two million different components listed you are sure to find the part you need.

Feel free to visit us today at our online store:

LittleDiode.com

Looking forward to providing you with the best possible service.